

***ARMY TM 10-3930-675-10-2**

MARINE CORPS TM 11078A-OR/2

TECHNICAL MANUAL

OPERATOR'S MANUAL

FOR

**ROUGH TERRAIN CONTAINER HANDLER (RTCH):
RT 240; 53,000 LB CAPACITY; 4 X 4
(NSN 3930-01-473-3998)**

**ROUGH TERRAIN CONTAINER HANDLER (RTCH):
RT 240; 53,000 LB CAPACITY; 4 X 4 (RESET)
(NSN 3930-01-473-3998)**

**ROUGH TERRAIN CONTAINER HANDLER (RTCH):
RT 240V2; 53,000 LB CAPACITY; 4 X 4
(NSN 3930-01-522-7364)**



***SUPERSEDURE NOTICE** - This manual supersedes TM 10-3930-675-10 dated July 2001.
DISTRIBUTION STATEMENT A - Approved for public release; distribution is unlimited.

HEADQUARTERS, DEPARTMENT OF THE ARMY

DECEMBER 2006

Marine Corps Publication Control Number: 184 110781 00

DEPARTMENT OF THE NAVY
Headquarters, U.S. Marine Corps
Washington, DC 20380-0001

25 September 2006

1. This Technical Manual (TM), authenticated for Marine Corps use and effective upon receipt, provides operation and lubrication instructions as determined by TM 11078-OR for Rough Terrain Container Handler (RTCH), National Stock Number (NSN) 3830-01-522-7364.
2. Submit notice of discrepancies or suggested changes on a NAVMC 10772. The NAVMC may be submitted via the Internet using website <https://pubs.ala.usmc.mil/home.htm>, scrolling down to the NAVMC 10772 Tracking Program and following instructions provided. It may also be submitted by electronic mail to mbmatcommarlogbases@logcom.usmc.mil, or by mailing paper copy NAVMC 10772 in an envelope addressed to Commander, Marine Corps Systems Command, Attn: Assistant Commander Acquisition and Logistics (LOG/TP), 814 Radford Blvd, Suite 20343, Albany, Georgia 31704-0343.

BY DIRECTION OF THE COMMANDANT OF THE MARINE CORPS

OFFICIAL:

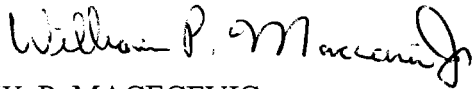

W. P. MACECEVIC
Program Manager, Engineer Systems
Marine Corps Systems Command

DISTRIBUTION: EDO

WARNING SUMMARY

This warning summary contains general safety warnings and hazardous material warnings that must be understood and applied during operation and maintenance of this equipment. Failure to observe these precautions could result in serious injury or death to personnel. Also included are explanations of safety and hazardous materials icons used within the technical manual.



BIOLOGICAL - abstract symbol bug shows that a material may contain bacteria or viruses that present a danger to life or health.



CHEMICAL - drops of liquid on hand shows that the material will cause burns or irritation to human skin or tissue.



ELECTRICAL - electrical wire to arm with electricity symbol running through human body shows that shock hazard is present.



EYE PROTECTION - person with goggles shows that the material will injure the eyes.



FIRE - flame shows that a material may ignite and cause burns.

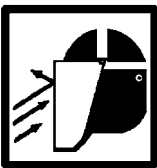

FLYING PARTICLES - arrows bouncing off face with face shield shows that particles flying through the air will harm face.



HEAVY PARTS - hand with heavy object on top shows that heavy parts can crush and harm.



HEAVY PARTS - heavy object on human figure shows that heavy parts present a danger to life and limb.



HOT AREA - hand over object radiating heat shows that part is hot and can burn.



RADIOACTIVE - identifies a material that emits radioactive energy and can injure human tissue or organs.



VAPOR - human figure in a cloud shows that material vapors present a danger to life or health.

FOR INFORMATION ON FIRST AID, REFER TO FM 4-25.11.



WARNING

CARBON MONOXIDE (EXHAUST GASES) CAN KILL!

- Carbon monoxide is a colorless, odorless, deadly poison which, when breathed, deprives the body of oxygen and causes suffocation. Exposure to air containing carbon monoxide produces symptoms of headache, dizziness, loss of muscular control, apparent drowsiness, and coma. Permanent brain damage or death can result from severe exposure.
 - Carbon monoxide occurs in exhaust fumes from internal combustion engines. Carbon monoxide can become dangerously concentrated under conditions of inadequate ventilation. The following precautions must be observed to ensure safety of personnel when engine of vehicle is operated.
1. **DO NOT** operate vehicle engine in enclosed areas.
 2. **DO NOT** idle vehicle engine without adequate ventilation.
 3. **DO NOT** drive vehicle with inspection plates or cover plates removed.
 4. **BE ALERT** for exhaust poisoning symptoms. They are:
 - Headache
 - Dizziness
 - Sleepiness
 - Loss of muscular control
 5. **If you see another person with exhaust poisoning symptoms:**
 - Remove person from area.
 - Expose to fresh air.
 - Keep person warm.
 - Do not permit physical exercise.
 - Administer cardiopulmonary resuscitation (CPR), if necessary.
 - Notify a medic.
 6. **BE AWARE.** The field protective mask for nuclear-biological-chemical (NBC) protection will not protect you from carbon monoxide poisoning.

The Best Defense Against Carbon Monoxide Poisoning Is Good Ventilation!



WARNING
BATTERIES

- To avoid injury, eye protection and acid-resistant gloves must be worn when working around batteries. DO NOT smoke, use open flame, make sparks or create other ignition sources around batteries. If a battery is giving off gases, it can explode and cause injury to personnel. Remove all jewelry such as rings, ID tags, watches, and bracelets. If jewelry or a tool contacts a battery terminal, a direct short will result in instant heating, damage to equipment, and injury to personnel.
- Sulfuric acid contained in batteries can cause serious burns. If battery corrosion or electrolyte makes contact with skin, eyes or clothing, take immediate action to stop the corrosive burning effects. Failure to follow these procedures may result in death or serious injury to personnel.
 - a. **Eyes.** Flush with cold water for no less than 15 minutes and seek medical attention immediately.
 - b. **Skin.** Flush with large amounts of cold water until all acid is removed. Seek medical attention as required.
 - c. **Internal.** If corrosion or electrolyte is ingested, drink large amounts of water or milk. Follow with milk of magnesia, beaten egg or vegetable oil. Seek medical attention immediately.
 - d. **Clothing/Equipment.** Wash area with large amounts of cold water. Neutralize acid with baking soda or household ammonia.

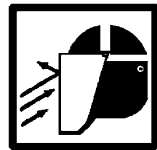

WARNING
COMPRESSED AIR

Compressed air used for cleaning purposes should never exceed 30 psi (207 kPa). Wear protective clothing (goggles/shield, gloves, etc.) and use caution to avoid injury to personnel.



WARNING
DIESEL FUEL HANDLING



- DO NOT smoke or permit any open flame in area of RTCH while you are servicing diesel fuel system. Be sure hose nozzle is grounded against filler tube during refueling to prevent static electricity. Failure to follow this warning may result in injury to personnel or equipment damage.
- DO NOT perform fuel system checks, inspections or maintenance while smoking or near fire, flames or sparks. Fuel may ignite, causing damage to machine and injury or death to personnel.
- Operating personnel must wear fuel-resistant gloves when handling fuels. If exposed to fuel, promptly wash exposed skin and change fuel-soaked clothing.



WARNING
DRY CLEANING SOLVENT



Dry cleaning solvent P-D-680 type III is toxic and flammable. Wear protective goggles and gloves and use only in a well-ventilated area. Avoid contact with skin, eyes, and clothes and do not breathe vapors. DO NOT use near open flame or excessive heat. The solvent's flash point is 200°F (94°C). If you become dizzy while using dry cleaning solvent, get fresh air immediately and get medical help. If solvent contacts eyes, wash your eyes and get medical aid immediately.



WARNING
FIRE EXTINGUISHER

Discharging large quantities of dry chemical fire extinguisher in cab may result in temporary breathing difficulty during and immediately after the discharge event. If at all possible, discharge fire extinguisher from outside the cab. Ventilate cab thoroughly prior to reentry.



WARNING
HAZARDOUS WASTE DISPOSAL

When servicing this vehicle, performing maintenance, or disposing of materials such as engine coolant, transmission fluid, lubricants, battery acids or batteries, and CARC paint, consult your unit/local hazardous waste disposal center or safety office for local regulatory guidance.

WARNING

INFRARED (IR) LIGHTS

DO NOT look directly at IR source without eye protection and maintain a minimum of 12 inches from energized IR lights to prevent possible eye discomfort or damage.



WARNING
NBC EXPOSURE



If NBC exposure is suspected, all air cleaner media should be handled by personnel wearing protective equipment. Consult your NBC Officer or NBC NCO for appropriate handling or disposal procedures.

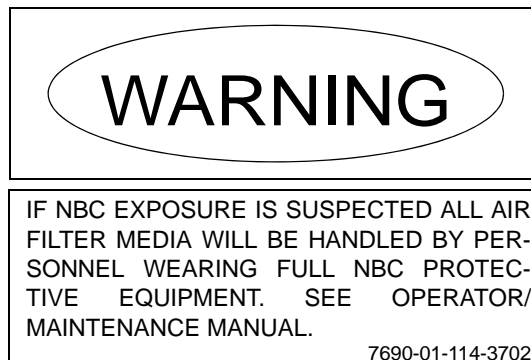

To order this NBC decal use:

National Stock Number (NSN) - 7690-01-114-3702

Part Number (PN) - 12296626

Commercial and Government Entity Code (CAGEC) - 19207

WARNING
OPERATION SAFETY

- **DO NOT** allow riders on the RTCH. Failure to follow this warning may result in serious injury or death to personnel.
- **BE ALERT** for personnel in the area while operating RTCH. Always check to ensure area is clear of personnel and obstructions before moving. Failure to follow this warning may result in serious injury or death to personnel or damage to equipment.
- **ALL FOUR** corners of the tophandler must be in contact with the container when locking or releasing the twistlocks. In addition, during release, all four corners of the container must be resting firmly on the surface supporting it. Failure to follow this warning may result in injury or death to personnel or damage to equipment.
- If the indicator lamps for the overload system are inoperative, the RTCH must not be operated. Safe operation may be affected if the machine is used when the indicator lamps are defective. Failure to follow this warning may result in injury or death to personnel or damage to equipment.
- **NEVER** operate the RTCH or move the load near a power line or overhead wires. Failure to follow this warning may result in injury or death to personnel or damage to equipment.
- RTCH must not be driven when container load is in fully raised position. RTCH is less stable when traveling with the load in a raised position. Maintain proper transport mode load height and position when driving to prevent forward tipping. Failure to follow this warning may result in injury or death to personnel or damage to equipment.
- Never leave the operator's position without applying the parking brake. Failure to follow this warning may result in injury or death to personnel or damage to equipment.
- Never use external starting fluid or spray to aid in starting the engine. Use only ether injector switch located on the instrument panel (WP 0004 00). Failure to follow this warning may result in injury or death to personnel or damage to equipment.
- Always use a ground guide when driving the RTCH up or down ramps in preparation for highway, marine or air transport. Failure to use a ground guide may result in an accident, causing injury or death to personnel or damage to equipment.
- Wear the safety belt at all times while operating the RTCH-RT 240V2.



WARNING

PRESSURIZED COOLING SYSTEM



- **DO NOT** service cooling system unless engine has been allowed to cool down. **DO NOT** remove radiator cap. Add coolant only to expansion tank. This is a pressurized cooling system and escaping steam or hot coolant will cause serious burns.
- Wear effective eye, glove, and skin protection when handling coolants. Failure to do so may cause injury.



WARNING

SLAVE STARTING

- When slave starting machine, use NATO slave cable that **DOES NOT** have loose or missing insulation.
- **DO NOT** proceed if suitable cable is not available.
- **DO NOT** use civilian-type jumper cables.

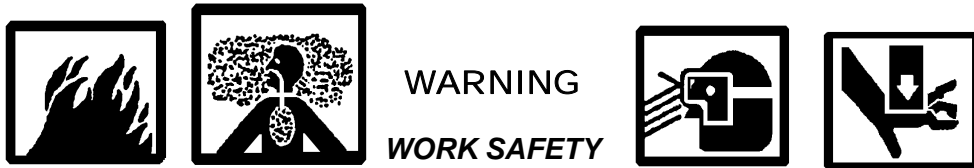

- Ether is highly flammable and explosive. **DO NOT** perform ether quick-start system checks or inspections while smoking or near fire, flame or sparks. Failure to follow this warning may cause a fire and explosion, causing serious injury or death to personnel.
- Avoid breathing cold start system fluid vapors. Wear goggles and fuel-resistant gloves when handling fluid. Failure to follow this warning may cause serious injury or death to personnel.
- Lifting cables, chains, hooks, and slings used for lifting vehicle must be in good condition and of suitable capacity. Failure to follow this warning may result in injury or death to personnel and damage to equipment.
- Improper use of lifting equipment and improper attachment of cables to machine can result in serious personnel injury and equipment damage. Observe all standard rules of safety.

WARNING

While operating a RTCH in self-deployment, 2-wheel steering mode, the maximum travel speed of 23 mph should never be exceeded. When on downhill grades; extra care should be exercised not to allow the RTCH to coast into an overspeed condition and obtain speeds in excess of 23 mph. Failure to keep maximum speed at or below 23 mph could result in major damage to the drive train components and loss of operator control. Under no circumstances should the parking brake be applied to attempt to rapidly reduce the speed of the RTCH.

CHANGE No. 1
TM 10-3930-675-10-2
TM 11078A-OR/2

HEADQUARTERS
DEPARTMENTS OF THE ARMY
AND MARINE CORPS
Washington, D.C., 30 May 2008

TECHNICAL MANUAL
OPERATOR'S MANUAL
FOR

ROUGH TERRAIN CONTAINER HANDLER (RTCH):
RT 240; 53,000 LB CAPACITY; 4 X 4
(NSN 3930-01-473-3998)

ROUGH TERRAIN CONTAINER HANDLER (RTCH):
RT 240; 53,000 LB CAPACITY; 4 X 4 (RESET)
(NSN 3930-01-473-3998)

ROUGH TERRAIN CONTAINER HANDLER (RTCH):
RT 240V2; 53,000 LB CAPACITY; 4 X 4
(NSN 3930-01-522-7364)

TM 10-3930-675-10-2 and TM 11078A-OR/2, dated 01 December 2006, is changed as follows:

1. Remove old work packages and insert new work packages.
2. New or changed material is indicated by a vertical bar in the margin of the page and by a vertical bar adjacent to the art.

Remove Pages	Insert Pages
<i>A/(B Blank)</i>	<i>A/(B Blank)</i>
<i>i thru iv</i>	<i>i thru iv</i>
<i>WP 0007 00</i>	<i>WP 0007 00</i>
<i>WP 0012 00</i>	<i>WP 0012 00</i>
<i>WP 0013 00</i>	<i>WP 0013 00</i>
<i>DA Form 2028 Sample</i>	<i>DA Form 2028 Sample</i>
<i>DA Form 2028</i>	<i>DA Form 2028</i>
<i>DA Form 2028</i>	<i>DA Form 2028</i>
<i>DA Form 2028</i>	<i>DA Form 2028</i>

3. File this change sheet in front of the publication for reference purposes.

DISTRIBUTION STATEMENT A: Approved for public release; distribution is unlimited.

By Order of the Secretary of the Army:

GEORGE W. CASEY, JR.
General, United States Army
Chief of Staff

Official:

JOYCE E. MORROW
Administrative Assistant to the
Secretary of the Army
0811903

By Order of the Marine Corps:

G.W. TAYLOR
Product Group Director, PG-15
Ground Transportation Engineer Systems
Marine Corps Systems Command

DISTRIBUTION: To be distributed in accordance with the initial distribution (IDN) 256667 requirements for TM 10-3930-675-10-2.

MARINE CORPS DISTRIBUTION: PCN 184 110782 01

LIST OF EFFECTIVE PAGES/WORK PACKAGES

Date of issue for original manual is:

Original 01 December 2006

Change 1 30 May 2008

Total number of pages for front and rear matter is 32 and total number of work packages is 20 consisting of the following:

Page/WP No.	*Change No.	Page/WP No.	*Change No.
Cover (Back Blank)	0		
a to g/(h Blank)	0		
i to iv	1		
Ch. 1 title page	0		
WP 0001 00 (4 pages)	0		
WP 0002 00 (8 pages)	0		
WP 0003 00 (4 pages)	0		
Ch. 2 title page	0		
WP 0004 00 (12 pages)	0		
WP 0005 00 (36 pages)	0		
WP 0006 00 (10 pages)	0		
WP 0007 00 (26 pages)	1		
WP 0008 00 (20 pages)	0		
Ch. 3 title page	0		
WP 0009 00 (2 pages)	0		
WP 0010 00 (2 pages)	0		
WP 0011 00 (6 pages)	0		
Ch. 4 title page	0		
WP 0012 00 (14 pages)	1		
WP 0013 00 (24 pages)	1		
WP 0014 00 (2 pages)	0		
WP 0015 00 (2 pages)	0		
Ch. 5 title page	0		
WP 0016 00 (2 pages)	0		
WP 0017 00 (4 pages)	0		
WP 0018 00 (2 pages)	0		
WP 0019 00 (4 pages)	0		
WP 0020 00 (44 pages)	0		
Index-1 to Index-4	0		
Metric Conversion Chart	0		
Back Cover	0		

*Zero in this column indicates an original page or work package.

TECHNICAL MANUAL
TM 10-3930-675-10-2
TM 11078A-OR/2

HEADQUARTERS
DEPARTMENTS OF THE ARMY
AND MARINE CORPS
Washington, D.C., 01 December 2006

TECHNICAL MANUAL
OPERATOR'S MANUAL
FOR

ROUGH TERRAIN CONTAINER HANDLER (RTCH):
RT 240; 53,000 LB CAPACITY; 4 X 4
(NSN 3930-01-473-3998)

ROUGH TERRAIN CONTAINER HANDLER (RTCH):
RT 240; 53,000 LB CAPACITY; 4 X 4 (RESET)
(NSN 3930-01-473-3998)

ROUGH TERRAIN CONTAINER HANDLER (RTCH):
RT 240V2; 53,000 LB CAPACITY; 4 X 4
(NSN 3930-01-522-7364)

REPORTING ERRORS AND RECOMMENDING IMPROVEMENTS

You can help improve this publication. If you find any mistakes or if you know of a way to improve the procedures, please let us know. Submit your DA Form 2028 (Recommended Changes to Equipment Technical Publications), through the Internet, on the Army Electronic Product Support (AEPS) website. The Internet address is <https://aeps.ria.army.mil>. The DA Form 2028 is located under the Public Applications section in the AEPS Public Home Page. Fill out the form and click on SUBMIT. Using this form on the AEPS will enable us to respond quicker to your comments and better manage the DA Form 2028 program. You may also mail, fax or E-mail your letter or DA Form 2028 direct to: U.S. Army TACOM Life Cycle Management Command, ATTN: AMSTA-LC-LMPP/TECH PUBS, 1 Rock Island Arsenal, Rock Island, IL 61299-7630. The E-mail address is ROCK-TACOM-TECH-PUBS@conus.army.mil. The fax number is DSN 793-0726 or Commercial (309) 782-0726.

***SUPERSEDURE NOTICE** - This manual supersedes TM 11078A-OR dated March 2005.

DISTRIBUTION STATEMENT A - Approved for public release; distribution is unlimited.

Table of Contents

	Page Number
Warning Summary	a
How To Use This Manual	iii
CHAPTER 1 INTRODUCTORY INFORMATION WITH THEORY OF OPERATION	
WP 0001 00 General Information	0001 00-1
WP 0002 00 Equipment Description and Data	0002 00-1
WP 0003 00 Theory of Operation	0003 00-1
CHAPTER 2 OPERATING INSTRUCTIONS	
WP 0004 00 Description and Use of Operator's Controls and Indicators	0004 00-1
WP 0005 00 Operation Under Usual Conditions	0005 00-1
WP 0006 00 Operation Under Unusual Conditions	0006 00-1

Table of Contents - Continued

	Page Number
CHAPTER 2 OPERATING INSTRUCTIONS - CONTINUED	
WP 0007 00 Preparation for Transport	0007 00-1
WP 0008 00 Stowage and Decal, Data Plate, and Stencil Guide	0008 00-1
CHAPTER 3 OPERATOR TROUBLESHOOTING	
WP 0009 00 Troubleshooting Instructions	0009 00-1
WP 0010 00 Troubleshooting Symptom Index	0010 00-1
WP 0011 00 Troubleshooting Procedures	0011 00-1
CHAPTER 4 OPERATOR MAINTENANCE INSTRUCTIONS	
WP 0012 00 Preventive Maintenance Checks and Services (PMCS) Introduction	0012 00-1
WP 0013 00 Preventive Maintenance Checks and Services (PMCS)	0013 00-1
WP 0014 00 Engine Air Cleaner Servicing	0014 00-1
WP 0015 00 Refueling Procedures	0015 00-1
CHAPTER 5 SUPPORTING INFORMATION	
WP 0016 00 References	0016 00-1
WP 0017 00 Components of End Item (COEI) and Basic Issue Items (BII) Lists	0017 00-1
WP 0018 00 Additional Authorization List (AAL)	0018 00-1
WP 0019 00 Expendable and Durable Items List	0019 00-1
WP 0020 00 Error Codes	0020 00-1
Index	Index-1

HOW TO USE THIS MANUAL

INTRODUCTION

1. This manual is designed to help you operate the Army RESET and USMC configuration of the RT 240 Rough Terrain Container Handler (RTCH) and perform operator troubleshooting and maintenance on the equipment. This manual covers Army and USMC units with serial numbers ending in .0400 and above.
2. This manual is written in Work Package format:
 - a. Chapters divide the manual into major categories of information (e.g., *Introductory Information with Theory of Operation, Operating Instructions, Operator Troubleshooting, Operator Maintenance Instructions, and Supporting Information*).
 - b. Each chapter is divided into work packages, which are identified by a 6-digit number (e.g., 0001 00, 0002 00, etc.) located on the upper right-hand corner of each page. The work package page number (e.g., 0001 00-1, 0001 00-2, etc.) is located centered at the bottom of each page.
 - c. If a change package is issued to this manual, added work packages use the 5th and 6th digits of their number to indicate new material. For instance, work packages inserted between WP 0001 00 and WP 0002 00 are numbered WP 0001 01, WP 0001 02, etc.
3. Scan through this manual to become familiar with its organization and contents before attempting to operate or maintain the equipment.

CONTENTS OF THIS MANUAL

1. A *Warning Summary* is located at the beginning of this manual. Become familiar with these warnings before operating or performing operator troubleshooting or maintenance on the vehicle.
2. A *Table of Contents*, located in the front of the manual, lists all chapters and work packages in the publication.
 - a. The Table of Contents also provides *Reporting Errors and Recommending Improvements* information and DA Form 2028 addresses for the submittal of corrections to this manual.
 - b. If you cannot find what you are looking for in the Table of Contents, refer to the alphabetical *Index* at the back of the manual.
3. Chapter 1, *Introductory Information with Theory of Operation*, provides general information on the manual and the equipment.
4. Chapter 2, *Operating Instructions*, explains and illustrates all operator controls and indicators and describes how to perform all operating procedures for the RTCH: *Operation Under Usual Conditions, Operation Under Unusual Conditions, Preparation of Transport, and Stowage and Decal, Data Plate, and Stencil Guide*.
5. Chapter 3 covers all *Operator Troubleshooting*. WP 0010 00 contains a *Troubleshooting Symptom Index*. If the RTCH malfunctions, this index should always be consulted to locate the appropriate troubleshooting procedure.
6. Chapter 4 deals with *Operator Maintenance Instructions*. Major areas covered are *Preventive Maintenance Checks and Services (PMCS)* and operator-level maintenance tasks.
7. Chapter 5 includes *Supporting Information: References, Components of End Item (COEI) and Basic Issue Items (BII) Lists, Additional Authorization List (AAL), and Expendable and Durable Items List*. Of particular interest is WP 0020 00, *Error Codes*. This contains an explanation of the error code display that is shown when the RTCH experiences a mechanical malfunction and provides a complete list and explanation of all error codes resident on the vehicle.

FEATURES OF THIS MANUAL

1. WARNINGS, CAUTIONS, NOTES, subject headings, and other important information are highlighted in **BOLD** print as a visual aid.

WARNING

A WARNING indicates a hazard which may result in serious injury or death.

CAUTION

A CAUTION is a reminder of safety practices or directs attention to usage practices that may result in damage to equipment.

NOTE

A NOTE is a statement containing information that will make the procedures easier to perform.

2. Statements and words of particular interest may be printed in CAPITAL LETTERS to create emphasis.
3. Within a procedural step, reference may be made to another work package in this manual or to another manual. These references indicate where you should look for more complete information.
 - a. If you are told: "If red band is showing, service air cleaner as soon as possible (WP 0014 00)," go to work package WP 0014 00 in this manual for instructions on servicing the air cleaner.
 - b. If you are told: "Stow M1000 trailer loading ramps (TM 9-2330-381-14)," go to TM 9-2330-381-14, which is listed in the *References* work package, for complete information on stowing the M1000 loading ramps. Use the *Table of Contents* or alphabetical *Index* in TM 9-2330-381-14 to find procedures for the M1000 loading ramps.
4. Illustrations are placed after and close to the procedural steps to which they apply. Callouts placed on the art may be text or numbers or both, whichever method is easier for the soldier.
5. Numbers located at lower right corner of art (e.g., 350-001; 350-002, etc.) are art control numbers and are used for tracking purposes. Disregard these numbers.
6. Dashed leader lines used in illustrations indicate that called out items are not visible in the view depicted (i.e., they are located within the structure).
7. Technical instructions include metric units as well as standard units. For your reference, a *Metric Conversion Chart* is located on the inside back cover of the manual.

NOTE

If at any time you are unsure how to use this manual or you cannot locate the information you need, notify your supervisor.

CHAPTER 1
INTRODUCTORY INFORMATION WITH
THEORY OF OPERATION

GENERAL INFORMATION

0001 00

SCOPE

1. **Type of Manual.** This manual is for use in operating and performing operator maintenance on the Rough Terrain Container Handler (RTCH), RT 240V2.
2. **Equipment Name and Model Number.** Rough Terrain Container Handler (RTCH): RT 240V2, 53,000 lb (24,040 kg) capacity, 4 x 4.
3. **Purpose of Equipment.** The RTCH-RT 240V2 is designed to lift and stack 20 to 40 ft International Standards Organization (ISO) containers, loaded to a gross weight of 53,000 lb (24,040 kg).

REPORTING MATERIAL DEFECTS

If your RTCH needs improvement, let us know. Prepare a Product Quality Deficiency Report (PQDR) standard form 368 IAW MCO 4855.1 PQDR to report deficiencies in equipment.

CORROSION PREVENTION AND CONTROL (CPC)

Corrosion Prevention and Control (CPC) of USMC materiel is a continuing concern. It is important that any corrosion problems with this item be reported so that the problem can be corrected and improvements can be made to prevent the problem in future items.

OZONE DEPLETING SUBSTANCES

Listing to be provided by requiring activity.

PREPARATION FOR STORAGE OR SHIPMENT

For preparation for storage or shipment procedures, refer to TM 10-3930-675-24.

WARRANTY INFORMATION

The vehicles are warranted by Kalmar RT in accordance with SI 11078A-OI. This warranty is valid for 60 months from the date of acceptance by the unit or 5,000 cumulative hours of operation, whichever occurs first.

LIST OF ABBREVIATIONS/ACRONYMS

ABBREVIATION/ACRONYM	DEFINITION
NOTE	
Refer to ASME Y14.38-1999 for standard abbreviations.	
AAL.....	Additional Authorization List
BII.....	Basic Issue Items
C.....	Centigrade or Celsius
CAGEC.....	Commercial and Government Entity Code
CAN-BUS.....	Controller Area Network-BUS
CID.....	Cubic Inch Displacement
cm.....	Centimeter
COEI.....	Components of End Item
CPR.....	Cardio Pulmonary Resuscitation
ECM.....	Electronic Control Module
ECS.....	Electronic Control System
F.....	Fahrenheit
ft.....	Feet
gal.....	Gallon

LIST OF ABBREVIATIONS/ACRONYMS - CONTINUED

ABBREVIATION/ACRONYM	DEFINITION
GCWR.....	Gross Combination Weight Rating
GVWR.....	Gross Vehicle Weight Rating
hp.....	Horsepower
IAW.....	In Accordance With
IETM.....	Interactive Electronic Technical Manual
in.....	Inch
ISO.....	International Standards Organization
JOAP.....	Joint Oil Analysis Program
kg.....	Kilogram
km.....	Kilometer
kPa.....	Kilopascal
kph.....	Kilometers Per Hour
kW.....	Kilowatt
L.....	Liter
lb.....	Pound
lb-in.....	Pound Inch
lb-ft.....	Pound Foot
LC.....	Load Center
lph.....	Liters Per Hour
m.....	Meter
mA.....	Milliamps
MAP.....	Monoammonium Phosphate
mm.....	Millimeter
mph.....	Miles Per Hour
MPS.....	Maritime Preposition Ship
NATO.....	North Atlantic Treaty Organization
NBC.....	Nuclear Biological Chemical
Nm.....	Newton Meter
NSN.....	National Stock Number
OALH.....	Overall Lowered Height
OEM.....	Original Equipment Manufacturer
PMCS.....	Preventive Maintenance Checks and Services
P/N.....	Part Number
psi.....	Pounds Per Square Inch
PTO.....	Power Take-Off
qt.....	Quart
RO/RO.....	Roll-On/ Roll-Off
RPM.....	Revolutions Per Minute
RTCH.....	Rough Terrain Container Handler

GENERAL INFORMATION - CONTINUED

0001 00

LIST OF ABBREVIATIONS/ACRONYMS - CONTINUED

ABBREVIATION/ACRONYM	DEFINITION
SPORT.....	Solider's Portable On-System Repair Tool
MPS.....	Maritime Preposition Ship
U/I.....	Unit of Issue
V.....	Volts
yd.....	Yard

END OF WORK PACKAGE

EQUIPMENT CHARACTERISTICS, CAPABILITIES, AND FEATURES1. **Characteristics.**

- a. The RTCH-RT 240V2 is designed to lift, move, stack, or unstack 20 to 40 ft by 8 ft wide (6.10 to 12.19 by 2.44 m) wide ISO containers.
- b. The RTCH-RT 240V2 has a lift capacity of 53,000 lb (24,040 kg) and operates on hard and/or unimproved surfaces, including beach operations.
- c. The RTCH-RT 240V2 can be utilized as a forklift with an operator-installed forklift kit.

2. **Capabilities and Features.**a. **Capabilities.**

- (1) **Container handling capabilities:**
 - (a) Stack or unstack 8 ft 6 in. and 9 ft. 6 in. (2.59 and 2.90 m) high ISO containers, stacked three high, with a gross weight of 53,000 lb (24,040 kg) in the first row.
 - (b) Stack or unstack 8 ft 6 in. and 9 ft 6 in. (2.59 and 2.90 m) high ISO containers, stacked three high, with a gross weight of 27,500 lb (12,474 kg) in the second row.
 - (c) Stack or unstack 4 ft 3 in. (1.30 m) high ISO containers, stacked seven high.
 - (d) Container tophandler adjusts to 20 ft (6.10 m) or 40 ft (12.19 m) ISO container lengths.
 - (e) Container tophandler oscillates 7 degrees left and right.
 - (f) Container tophandler rotates 105 degrees clockwise and 40 degrees counterclockwise.
 - (g) Container tophandler tilts 12 degrees forward and 8 degrees to the rear.
 - (h) Container tophandler side shifts ± 15 in. (± 381 cm) from the center on each side.
- (2) Forklift kit is operator installed and attaches to the tophandler. The fork tines are adjustable from 24 in. (61 cm) center-to-center to 81.5 in. (207 cm) center-to-center. Lift capacity is 44,000 lb (19,958 kg).
- (3) Maximum speed of RTCH is 23 mph (37 kph) on level ground with NO LOAD; maximum speed on level ground LOADED is 15 mph (24 kph).
- (4) Maximum fording depth is 60 in. (1.52 m).
- (5) Operation in temperatures from -25°F to +125°F (-32°C to +52°C), and to -40°F (-40°C) with arctic kit installed.

b. **Features.**

- (1) Electronically controlled 400 hp (298 kW), six-cylinder turbocharged diesel engine.
- (2) Electronic semi-automatic shift controlled transmission with 4 ranges forward and 3 reverse. Operator selects range and electronic control module (ECM) controls shift points.
- (3) Drive axles provide traction for 2-wheel or 4-wheel drive.
- (4) Limited slip differentials and multi-disc-wet brakes are an integral part of the axle assemblies. Multi-disc-wet brakes are hydraulically cooled to prevent overheating. Accumulators store energy for the emergency braking system.
- (5) Steering system is capable of 2-wheel, 4-wheel, crab, and emergency modes of operation.
- (6) Parking brake is hydraulically released and spring-applied by disc brake assemblies mounted on the front and rear differentials.
- (7) Operator's cab has a fully adjustable operator's seat, fresh air (filtered) ventilation system, and heater/defroster/air conditioning systems.

EQUIPMENT CHARACTERISTICS, CAPABILITIES, AND FEATURES - CONTINUED

- (8) Operator's controls include: adjustable steering wheel, accelerator and brake pedals, transmission range selector, steering mode selection rocker switches, and a single joystick control for all boom, tophandler, and forklift operations.
- (9) Auto lubrication system: provides lubrication to front and rear steering knuckles and steering cylinders, rear axle pivot pin, boom folding cylinders, boom support pivot pins, and boom pivot pins. The system is set to activate from parameters programmed into the on-board logic system.
- (10) Solar maintenance charger: maintains battery's ability to accept a charge and release electrical energy; Includes a 24V DC solar panel and pulsing charge controller. The solar panel will provide 200 mA charge current in full sunlight to prevent batteries from discharging during periods of non-use or equipment storage. The pulsing algorithm helps to prevent parasitic drain.

c. Transport Modes.**NOTE**

Refer to WP 0007 00 for detailed instructions to prepare the RTCH for transport.

- **Self Deployment**
- **Highway Transport**
- **Rail Transport**
- **Marine Transport**
- **Air Transport**

LOCATION AND DESCRIPTION OF MAJOR COMPONENTS

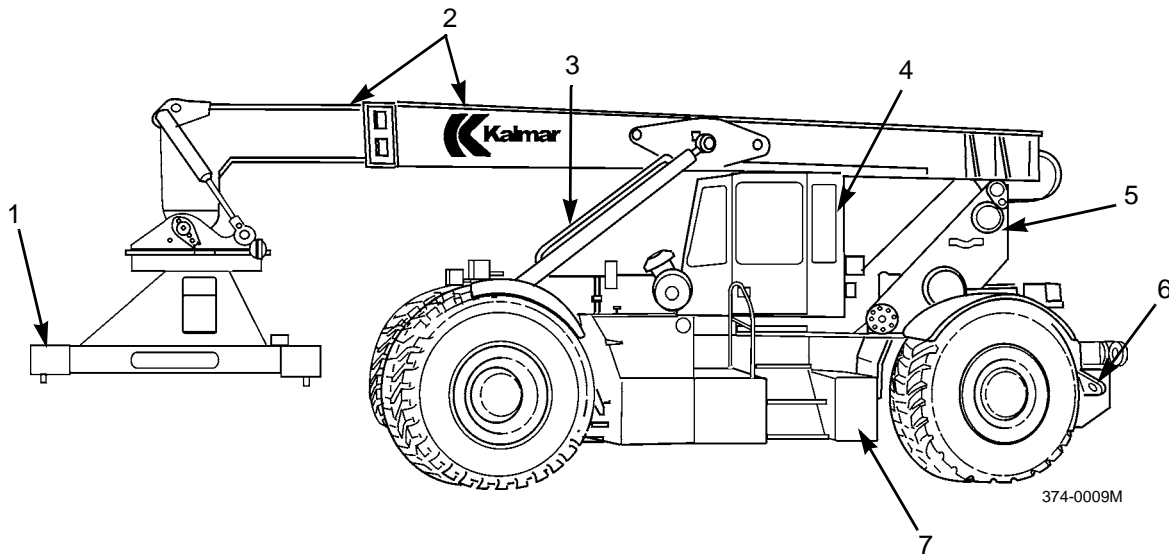

KEY	COMPONENT	DESCRIPTION
1	Tophandler	Electro-hydraulically operated 20 to 40 ft (6.10 to 12.19 m) tophandler. Capable of sideshifting, rotation, forward/rear tilting, left/right tilting, and load position leveling and locking. Also interfaces with forklift attachment.
2	Boom Assembly	Electro-hydraulically operated heavy-duty steel boom designed for moving, lifting, and stacking 20 to 40 ft (6.10 to 12.19 m) ISO containers.
3	Boom Lift Cylinders	Electro-hydraulically operated cylinders raise, lower, and support the boom assembly.
4	Operator's Cab	Contains all driving and container handling controls, as well as heating, air conditioning, and filtered ventilation system controls. During air transport operations, the cab is moved to the left side of the chassis, then lowered and secured in place.
5	Boom Support	Rear support and pivot point for the boom, to include an unlocking device that allows the boom assembly to be lowered into transport position.
6	Frame	A heavy-duty steel construction with tiedowns, towing lugs, and pintle hook.
7	Remote Hydraulic Control Compartment	Location of selected hydraulic remote controls and access to hydraulic system test and JOAP sampling ports.

LOCATION AND DESCRIPTION OF MAJOR COMPONENTS - CONTINUED

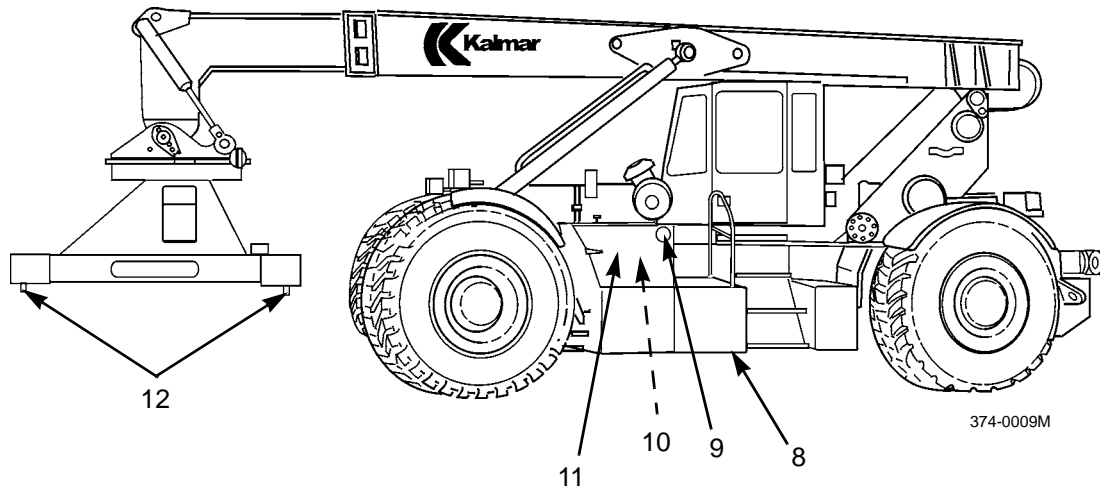

KEY	COMPONENT	DESCRIPTION
8	Dolly Wheels Storage Compartment	Storage location for the tophandler air transport dolly wheels.
9	Master Battery Switch	ON/OFF control of electrical power from batteries to vehicle electrical system.
10	Slave Receptacles	Provides an electrical connection for slave starting. A receptacle is located on each side of the RTCH.
11	Battery Compartment	Stores four 12V batteries and required cabling. Batteries are accessible from the side and/or the top.
12	Twistlocks	Electro-hydraulically operated and monitored ISO twistlocks, located at each corner of the tophandler. Also used to attach forklift attachment to tophandler.

LOCATION AND DESCRIPTION OF MAJOR COMPONENTS - CONTINUED

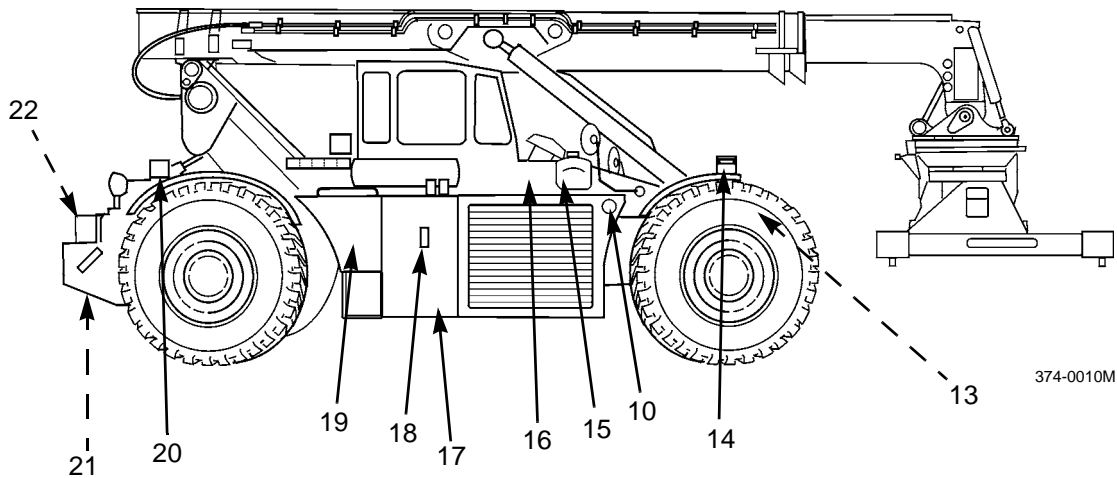

KEY	COMPONENT	DESCRIPTION
13	Front Headlights and Infrared Lights	Headlight and infrared lights.
14	Front Turn Lights and Blackout Lights	Blackout drive light and composite turn signal with blackout markers.
15	Coolant Expansion Tank	Contains cooling system overflow. Provides means to visually check coolant level and add coolant to system.
16	Engine Compartment	Houses the six-cylinder turbocharged diesel engine that supplies power for the automotive, electrical, and hydraulic systems.
17	Hydraulic Reservoir	Stores and vents system hydraulic oil.
18	Hydraulic Reservoir Sight Gage	Visual indicator of hydraulic oil level. If oil is NOT visible in sight gage with boom completely lowered and tophandler retracted, do not start engine.
19	Fuel Tank	Stores fuel supply for vehicle.
20	Rear Service and Blackout Lights	Composite tail, stop, and blackout markers, turn signals, backup lights, and infrared lights.
21	Bogie Wheels	Allows weight of machine to be distributed over more wheel area during aircraft loading and transport.
22	Boom Rest, Transport	Used for transporting machine when tophandler is removed and vehicle is in transport position. Cannot be used with tophandler installed.

EQUIPMENT DESCRIPTION AND DATA - CONTINUED

0002 00

EQUIPMENT DATA

Engine:

Manufacturer Cummins
 Model QSM 11
 Horsepower @ 2,150 RPM 400 hp (298 kW)
 Torque @ 1,200 RPM 1,450 lb-ft (1,966 Nm)
 Cylinders 6
 Displacement 661 CID (10.8 L)
 Weight 2,070 lb (939 kg)
 Fuel System Fully electronic
 Cooling System, Thermostat Range. 180° to 200°F (82° to 93°C)

Transmission:

Manufacturer ZF-Hydromedia
 Model WG-310
 Type 4 forward and 3 reverse speeds
 Range Selection Automatic, electronically-controlled

Axles:

Manufacturer Kessler
 Model:
 Front LT102PL341/528NLB4650
 Rear LT102PL341/528NLB4460
 Weight:
 Front 8,379 lb (3,800 kg)
 Rear 5,733 lb (2,600 kg)

Tires:

Front and Rear:
 Manufacturer Bridgestone
 Size 29.5 R 35 VRL
 Inflation 85 psi (586 kPa)
 Weight 2,750 lb (1,247 kg)
 Bogie Wheels (Transport Operations):
 Manufacturer Michelin
 Size 355/65 R 15 XZM
 Inflation 85 psi (586 kPa)
 Dolly Wheels (Tophandler Transport):
 Manufacturer Michelin
 Size 225/75 R 10 XZR
 Inflation 85 psi (586 kPa)

Dimensions:

Length:
 Tophandler Lateral 37.7 ft (11.5 m)
 Tophandler Longitudinal 49.2 ft (15.0 m)
 Height:
 Operational w/ Boom Level 13.1 ft (4.0 m)
 Highway Transport Mode 9.8 ft (3.0 m)
 Width, Tophandler Longitudinal 12 ft (3.66 m)

EQUIPMENT DESCRIPTION AND DATA - CONTINUED

0002 00

EQUIPMENT DATA - CONTINUED

Weights:

GVWR Operational w/all Fluids 118,500 lb (53,751 kg)
 GVWR Operational w/ Forklift Kit and/all Fluids 130,050 lb (58,990 kg)

Capacities:

Fuel Tank 103 gal. (390 L)
 Cooling System 23.7 gal. (89.7 L)
 Cooling, Engine Only 3.4 gal. (12.9 L)
 Hydraulic Oil Reservoir 180 gal. (681 L)
 Engine Crankcase w/Filter 38.6 qt (36.5 L)
 Transmission w/Filter 36 qt (34 L)

Electrical System:

Type 24V negative ground
 Batteries:
 Quantity 4
 Voltage 12V

Miscellaneous:

Maximum Lifting Capacity:
 First Stacking Row 53,000 lb (24,040 kg)
 Second Stacking Row 27,500 lb (12,474 kg)
 Maximum Lift Height 33 ft (10.06 m)
 Maximum Lifting Capacity, w/Forklift Kit
 First Stacking Row 44,000 lb (19,958 kg)
 Second Stacking Row 24,600 lb (11,158 kg)
 Maximum Lift Height, w/Forklift Kit 21.8 ft (6.65 m)
 Forklift Kit, Fork Tines Center-to-Center Range 24 to 81.5 in. (61 to 207 cm)
 Maximum Forward Reach (Boom Level) 20.6 ft (6.28 m)
 Curb-to-Curb Turning Circle:
 4-wheel Steering 65 ft (19.8 m)
 Ground Clearance 18 in. (45.7 cm)
 Fording Depth 60 in. (1.52 m)
 Maximum Travel Speeds:
 Empty 23 mph (37 kph)
 Loaded 15 mph (24 kph)

END OF WORK PACKAGE

INTRODUCTION

1. The RTCH-RT 240V2 consists of the following major components and functional systems: drive train, fuel system, exhaust system, cooling system, electrical and electronic systems, steering and brake systems, hydraulic system, cab system, and lifting boom with tophandler. A forklift kit may be added as required.
2. This work package explains how the components and systems of the RT 240V2 work together. A functional description is provided for each major component and system.

DRIVE TRAIN

1. The engine is a six-cylinder turbocharged diesel that supplies power to the transmission. The engine cooling system is pressurized and includes a thermostat, controlled bypass, and coolant expansion tank. Engine lubrication is pressurized and a full-flow filter continuously cleans oil.
2. The transmission is a semi-automatic, electronically controlled unit. The operator electronically selects range of gears and the transmission ECM controls shift points up to the highest selected gear. A shift inhibitor circuit controls downshifts in forward and reverse gears. The transmission can be manually or electronically shifted through 4 forward and 3 reverse gears. A torque converter provides interface to the engine.
3. The driveshafts transmit rotation of the transmission output to the front and rear axles. Connections at both ends are made through universal joints to compensate for any misalignments due to operating on uneven surfaces.
4. The front and rear axles are identical in operating principles. Both axles are hydraulically steered with planetary wheel ends and wet-disc brakes. The rear axle oscillates above and below horizontal to allow for operation on uneven surfaces.

FUEL SYSTEM

1. Fuel to power the engine is pumped by an engine-mounted fuel pump from the fuel tank to the electronically controlled fuel injector nozzles.
2. The engine ECM manages, monitors, and stores key engine functions, including engine idle speed maximum engine speed limits, and engine diagnostic data.
3. The engine-mounted fuel/water separator is a spin-on replaceable type with drain.

EXHAUST SYSTEM

The exhaust system removes exhaust gases from the engine through the exhaust manifold and turbocharger. The gases flow into exhaust pipes and muffler to the atmosphere along the right side and to the rear of the operator's cab.

COOLING SYSTEM

1. The cooling system consists of an engine-mounted circulating pump, 180° to 200°F (82° to 93°C) thermostat, oil cooler/aftercooler manifolds, radiator, engine-mounted coolant filter, and hydraulically driven cooling fan.
2. The cooling system cools the engine by circulating pressurized ethylene glycol-based coolant through the engine and radiator.

ELECTRICAL SYSTEM

1. The system is 24V. Four 12V batteries, connected in series/parallel configuration and charged by an alternator across electronic rectifying and voltage stabilization circuits, provide the voltage.
2. The positive pole is connected across the master battery switch. The negative pole is connected to the chassis.
3. NATO slave-starting receptacles are provided.
4. The Solar Maintenance Charger includes a 24V DC solar panel and pulsing charge controller. The pulsing algorithm helps to prevent and remove harmful sulfation crystals from the battery plates. The solar panel will provide 200 mA charge current in full sunlight to prevent batteries from discharging during periods of non-use or equipment storage.

STEERING SYSTEM

1. The electro-hydraulic steering system provides three modes of steering control: 2-wheel steering, 4-wheel steering, and crab steering.
2. The variable rate steering system uses two front and two rear hydraulic steering cylinders and electronic wheel position sensors connected to an ECM to maintain direction and control. The variable rate system allows the system to change or adjust to different modes of operation.
3. An emergency steering pump is provided in the event the engine is inoperative. If the engine quits while operating the RTCH, the emergency steering pump provides sufficient hydraulic pressure to control the machine until it is brought to a safe stop.

BRAKE SYSTEM

1. The brakes are totally enclosed within the front and rear drive axle housings, next to the wheel ends.
2. The brake system is a wet-brake system that is comprised of three separate hydraulic circuits: service brake circuit, cooling circuit, and parking brake circuit.
3. The brake system also includes six pressurized accumulators that provide adequate stored energy to stop the RTCH in the event of engine shutdown.
4. The service brake circuit is applied by depressing either the left or right floor-mounted hydraulic brake pedals. Brake pressure is applied to eight cylinders per side within the front axle and one cylinder per side in the rear axle.
5. The brake system cooling circuit cools the brake disks using oil pumped from the main hydraulic system through brake chambers during operation.
6. The parking brake assemblies are mounted at the input flanges of the front and rear axles. The brakes are applied by spring pressure and released hydraulically. A warning buzzer sounds if the operator leaves the seat without applying the parking brake. The parking brake should never be applied as an emergency brake or while the vehicle is moving. Application of the parking brake while the vehicle is moving can result in major drive train damage.

HYDRAULIC SYSTEM

The RTCH hydraulic system comprises of the following major components that provide hydraulic power to operate and control the container tophandler, boom, steering, and brake systems. In addition, the hydraulic system is used to place the cab and bogie wheels into transport mode.

1. Three variable piston-type hydraulic pumps are driven by the transmission power take-off (PTO). The pumps provide hydraulics for the steering system and tophandler.
2. One double vane-type pump is driven by the transmission PTO. It provides hydraulics for the boom cylinders, service, and parking brake systems.
3. One single-vane pump is driven by the engine. It provides hydraulics for a cooling fan.
4. Main valves control the main hydraulics. The valves are controlled by an electro-hydraulic servo system from the joystick control in the operator's cab.
5. High-pressure oil filters clean hydraulic oil before returning oil to the reservoir. Breather filters allow venting of the hydraulic reservoir.
6. Hydraulic system oil cooler and fan maintain and control hydraulic oil temperature. The cooling fan is powered by hydraulics from an engine-driven hydraulic pump.
7. Emergency systems: one ground-driven hydraulic pump maintains steering control in the event of engine failure; a 24V electric hydraulic pump provides power to lower the boom and release the twistlocks in the event of engine failure. The electric pump also provides a means to place the operator's cab into the transport mode.

CAB SYSTEM

1. The operator's cab is a sound and weather insulated unit that provides the operator with the systems to control and monitor both standard automotive functions and container handling functions. The following components or systems are also contained within the cab:
 - a. Adjustable steering column and adjustable seat.
 - b. Heater, air conditioning, and filtered ventilation system.
 - c. Portable fire extinguisher and rifle mount.
2. The air conditioning unit is part of the cab heater and is mounted at the front of the cab.
 - a. It consists of an evaporator coil, blower motor, control valves, and air ducts.
 - b. The system is turned on by operating the air conditioning control switch on the instrument panel.
 - c. A three-speed blower switch controls airflow.
 - d. The temperature control switch controls refrigerant flow through the evaporator coil to maintain an even cab temperature.

ELECTRONIC SYSTEM

The RTCH-RT 240V2 is equipped with several electronic modules, all connected using CAN-BUS technology. The modules can be diagnosed using the IETM and OEM testing equipment. They assist in the operation of major systems such as engine, transmission shifting, steering mode and wheel position, the safe working load control, and many related functions that require data input to operate correctly for the intended uses of the RTCH-RT 240V2.

LIFTING BOOM AND TOPHANDLER

The lifting boom and tophandler is an electro-hydraulic operated, heavy-duty telescoping boom and spreader assembly designed to lift, move, and stack/unstack 20 to 40 ft (6.10 to 12.19 m) ISO containers. The operator joystick provides complete control of the lifting boom and tophandler during container handling operations. The boom provides lifting/lowering and extending/retracting operations. The tophandler or spreader provides for sideshifting, rotation, forward/rear tilting, left/right tilting, and load leveling and locking operations. The tophandler also provides interface capability with a forklift attachment.

FORKLIFT KIT

The forklift kit is attached to the tophandler twistlocks and two hydraulic hose quick-disconnects. Forklift operation is controlled from the tophandler joystick, and includes adjustable fork tines. The fork tines and vertical support beams fold under the forklift framework for transport.

END OF WORK PACKAGE

CHAPTER 2
OPERATING INSTRUCTIONS

GENERAL

DO NOT attempt to operate the RTCH-RT 240V2 until becoming familiar with the location and use of all controls and indicators. This work package describes all operator controls and indicators.

INSTRUMENT PANEL

1. **Gage and Switch Panel.**

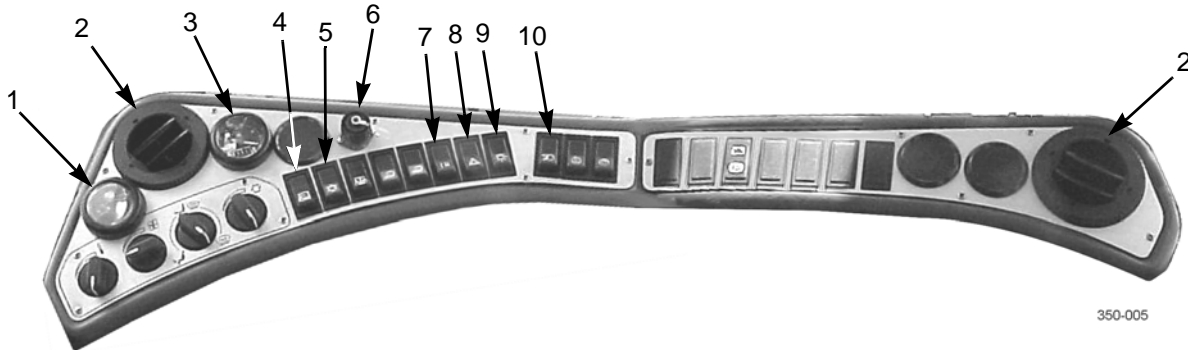

Key	Control or Indicator	Function
1	Fuel Gage	Indicates amount of fuel in fuel tank when ignition switch is ON.
2	Air Vents	Vents air into cab from heater/ventilator/defroster and air conditioner. Louvered openings are adjustable.
3	Hour Meter	Records hours of machine operation.
4	Cab Air Circulation Control Switch	Two-position rocker switch provides selection of recirculated air or fresh air within the cab.
5	Air Conditioning Control Switch	ON/OFF rocker switch controls cab air conditioning operation.
6	12V Utility Plug	Supplies 12V power to operate utilities.
7	IR Light Switch	ON/OFF rocker switch controls operation of infrared lights.
8	Hazard Warning Light Switch	ON/OFF rocker switch controls hazard warning lights.
9	Service Light Switch	ON/OFF rocker switch controls headlights and taillights.
10	Blackout Drive/Marker Light Switch	ON/OFF rocker switch controls blackout drive/marker lights.

INSTRUMENT PANEL - CONTINUED

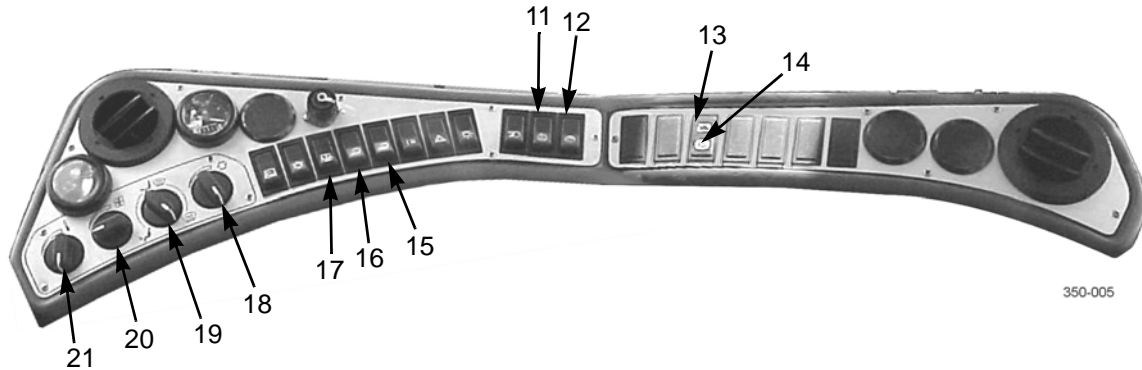

Key	Control or Indicator	Function
11	Ether Injector Switch	Spring-loaded rocker switch is used to inject a metered amount of ether while cranking engine during cold weather starting.
12	Auxiliary Pump Switch	Spring-loaded rocker switch is used, in the event of an engine failure or shutdown, to lower the boom, unlock twistlocks, and raise/retract the boom. The auxiliary pump is also used to reposition operator's cab for transport.
13	Alternator Charging Lamp	Red light comes ON when alternator fails to operate properly.
14	Parking Brake Indicator Light	Red light comes ON when parking brake is set.
15	Tophandler Work Light Switch	ON/OFF rocker switch controls tophandler work lights.
16	Boom Work Light Switch	ON/OFF rocker switch controls boom work lights.
17	Arctic Heater Switch (if equipped)	ON/OFF rocker switch operates arctic heater, if equipped.
18	Air Conditioner Temperature Control Switch	Switch rotates to control air conditioner output within the cab. Rotate switch clockwise to decrease temperature.
19	Heater and Defroster Selection Switch	Three-position switch selects airflow direction to windshield, operator, or both.
20	Fan Switch	Switch rotates to control heater/air conditioner fan speed. Rotate switch clockwise to increase fan speed.
21	Heater Temperature Control Switch	Switch rotates to control heater output within the cab. Rotate switch clockwise to increase temperature.

INSTRUMENT PANEL - CONTINUED

2. **Steering Column Switches and Controls.**

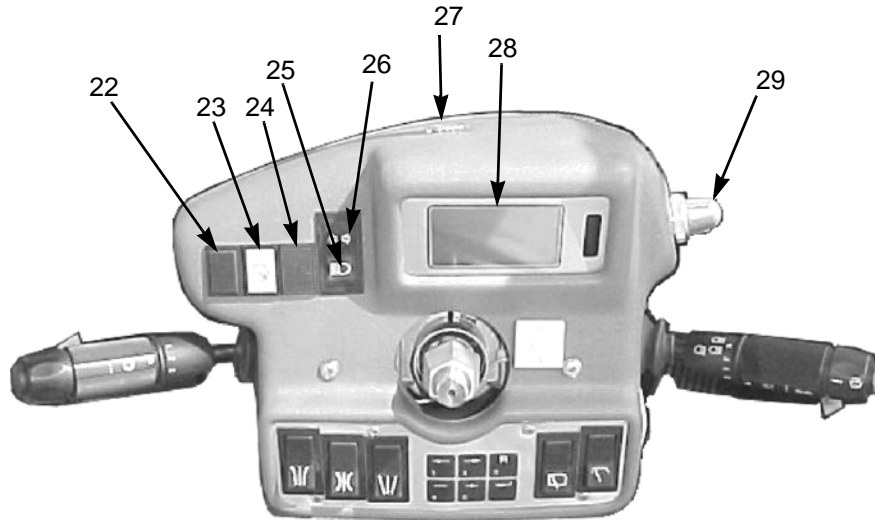

434-20005

Key	Control or Indicator	Function
22	Twistlocks LOCKED Indicator Light	GREEN indicator light is lit when twistlocks are locked.
23	Twistlocks ALIGNMENT Indicator Light	YELLOW indicator light is lit during twistlock alignment.
24	Twistlocks UNLOCKED Indicator Light	RED indicator light is lit when twistlocks are unlocked.
25	High Beam Indicator Light	Indicator light is BLUE when headlight high beams are on.
26	Turn Signal Indicator Lights	Left/right directional arrow flashes GREEN whenever turn signal lights are flashing. Both arrows flash when hazard warning light switch is on.
27	Diagnostic Connector	Connection point for SPORT diagnostic computer or commercial laptop computer.
28	Electronic Control System (ECS) Display Screen	Provides machine and container handling operational information, including an OVERLOAD indicator. Displays system error codes (WP 0020 00) and operational and service menus. Refer to <i>ECS Display Screens</i> on page 0004 00-6, for additional information.
29	Ignition Switch	Operates gages/switches/sending units, instrument panel lights, and engine starting.

INSTRUMENT PANEL - CONTINUED

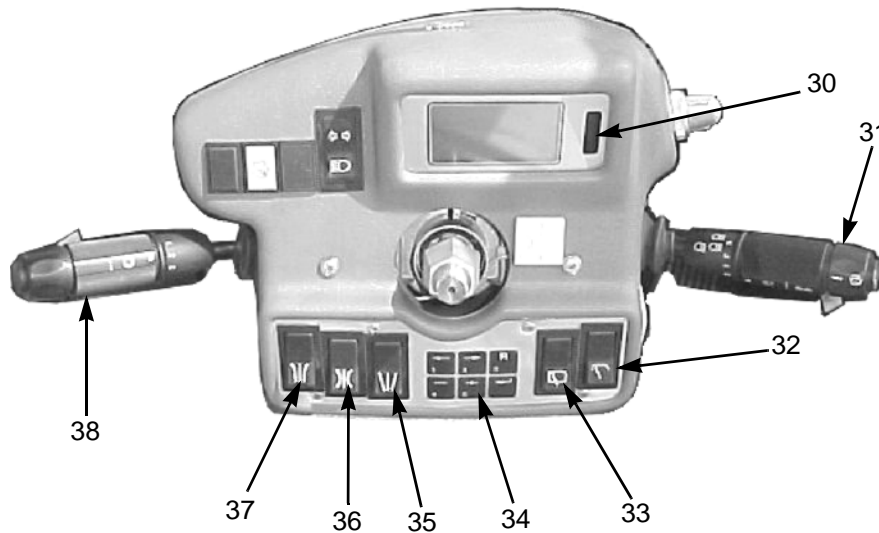

434-20005

Key	Control or Indicator	Function
30	Warning Indicator Light	RED Indicator light flashes to notify operator that an abnormal condition or system malfunction has occurred. Operator must refer to ECS display screen for further information. Systems tied to indicator light are: (a) Engine — low oil pressure (b) Engine — high coolant temperature (c) Transmission — high temperature (d) Transmission — low oil pressure (e) Steering — angle error (f) ECM — computer errors (g) Sensors — signal problems (h) Overload System — Overload condition
31	Accessory Control Lever	Provides controls for machine lights, turn signals, front windshield wiper and washer, and horn.
32	Roof Window Wiper Switch	ON/OFF rocker switch controls roof window wiper motor.
33	Rear Window Wiper Switch	ON/OFF rocker switch controls rear window wiper motor.
34	Electronic Control System (ECS) Menu Selection Buttons	Six buttons are used to access ECS menus, scroll between menus, view error codes, and reset systems. Refer to <i>ECS Menu Selection Buttons</i> on page 0004 00-5, for additional information.
35	Crab Steering Switch	ON/OFF rocker switch selects crab steering mode of operation.
36	4-Wheel Steering Switch	ON/OFF rocker switch selects 4-wheel steering mode of operation.
37	2-Wheel Steering Switch	ON/OFF rocker switch selects 2-wheel steering mode of operation.
38	Transmission Control Lever	Used to manually select transmission gear range and vehicle direction.

INSTRUMENT PANEL - CONTINUED

3. **ECS Menu Selection Buttons.**

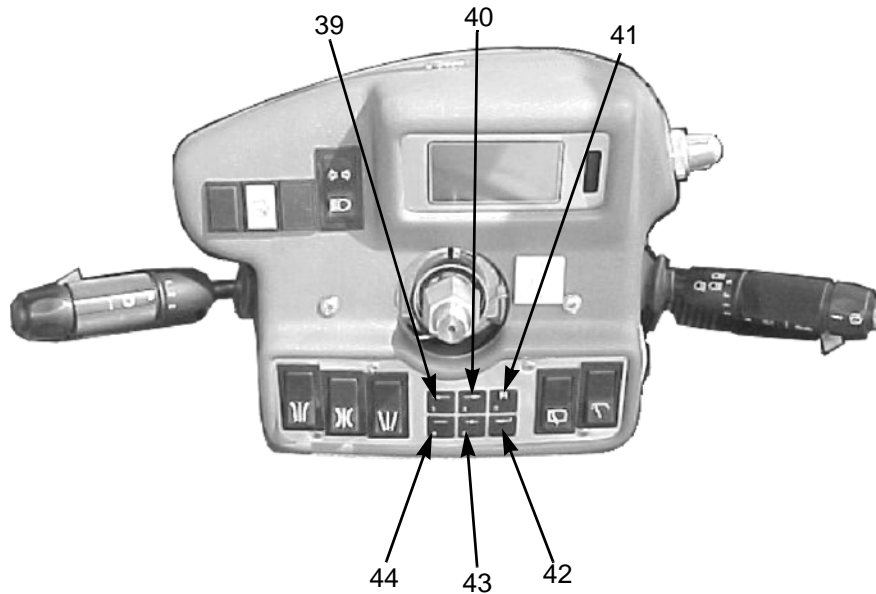

434-20005

Key	Control or Indicator	Function
39	Left Arrow Button	Press to scroll backward through menus on ECS display screen.
40	Right Arrow Button	Press to scroll forward through menus on ECS display screen.
41	Error Message Reset "R" Button	Used to reset the ECS display screen.
42	ENTER Button	Used by maintenance personnel when setting up and calibrating vehicle monitoring systems.
43	Value Increase "+" Button	Used by maintenance personnel when setting up and calibrating vehicle monitoring systems.
44	Value Decrease "-" Button	Used by maintenance personnel when setting up and calibrating vehicle monitoring systems.

INSTRUMENT PANEL - CONTINUED

4. **ECS Display Screens.**

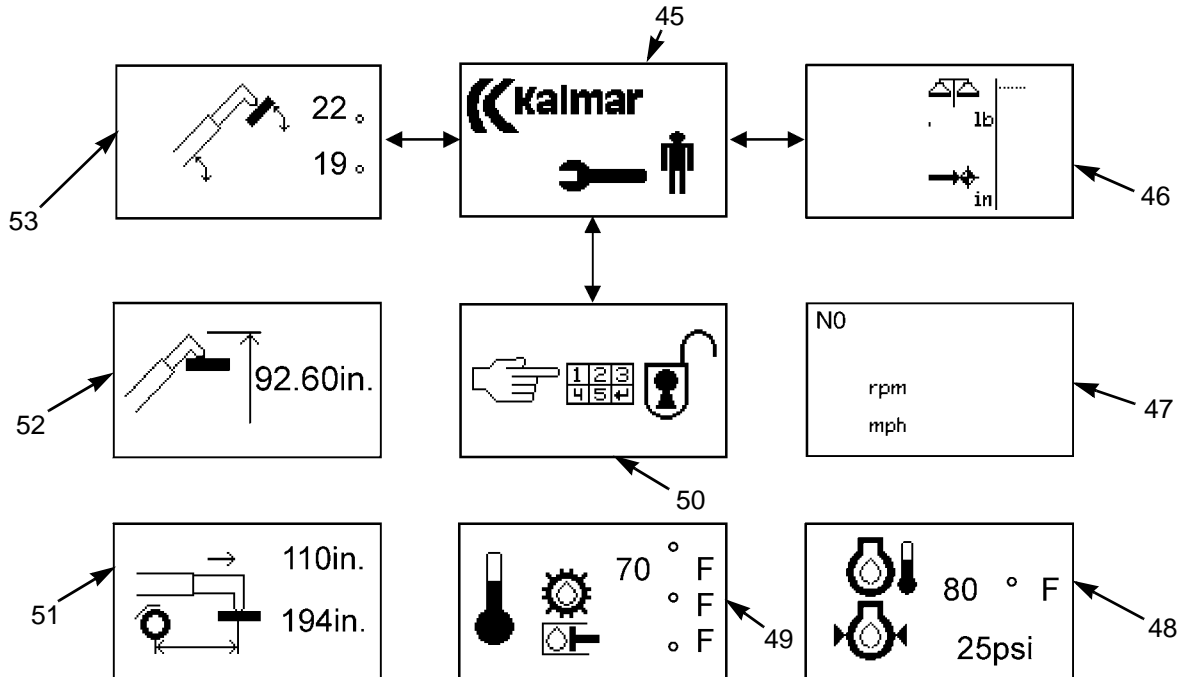

374M-00478

Key	Control or Indicator	Function
45	ECS Icon Screen	Starting screen for menu selection.
46	Operational Screen	Displays the following data: (a) Load weight (b) Load center, in. or meters
47	Displays the following data:	(a) Transmission direction and gear range (b) Engine RPM (c) Vehicle mph
48	Engine Monitoring Screen	Displays engine oil pressure and temperature.
49	Temperature Monitoring Screen	Displays outside ambient, transmission, and hydraulic system temperatures (°F).
50	Service and Maintenance Access Screen	Displays screens that are used by maintenance personnel for fault identification, setup, and calibration procedures.
51	Boom Extension Screen	Display of boom extension, in in. or meters.
52	Boom Height Screen	Display of boom height, in in. or meters.
53	Boom and Tophandler Lift Angle Screen	Display of boom and tophandler lift angles, in degrees.

STEERING WHEEL AND STEERING COLUMN CONTROLS

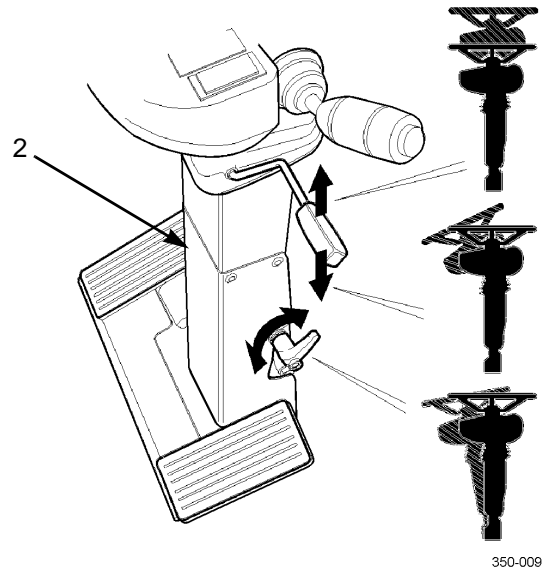
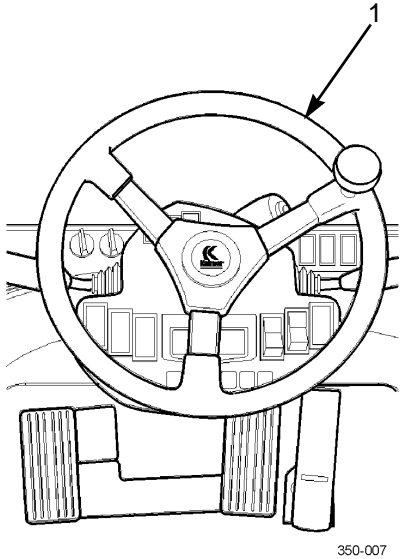

Key	Control or Indicator	Function
1	Steering Wheel	Controls vehicle direction of travel. Turn steering wheel clockwise to turn right, and counterclockwise to turn left.
2	Adjustable Steering Column	Upper control handle adjusts steering wheel height and angle. Lower control handle adjusts steering column tilt position.

SEAT CONTROLS

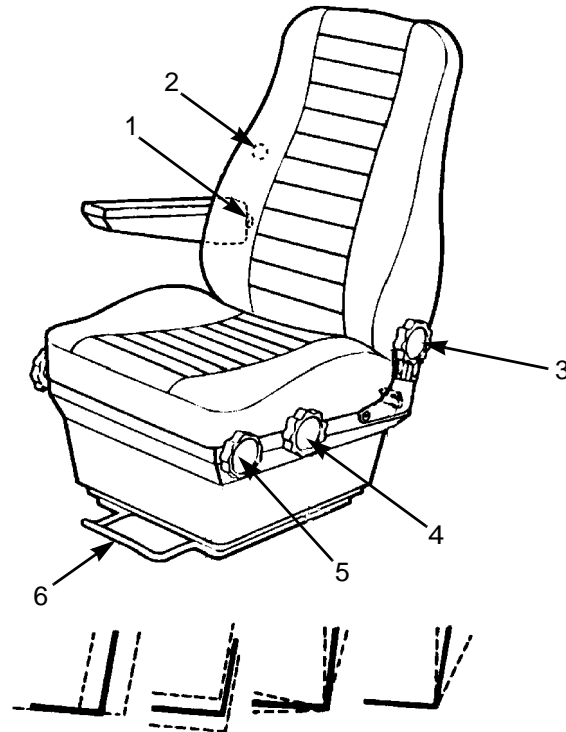

350-010

Key	Control or Indicator	Function
1	Armrest Tilt Adjustment	Turn adjusting knob until desired armrest tilt is achieved.
2	Lumbar Adjustment Knob	Rotate knob forward to increase and backward to decrease lumbar support.
3	Backrest Tilt Adjustment	Turn adjusting knob until desired backrest tilt is achieved.
4	Seat Tilt Adjustment Knob	Turn adjusting knob until desired seat tilt is achieved.
5	Seat Height Adjustment Knob	Turn adjusting knob until desired height is achieved.
6	Fore and Aft Seat Adjustment Lever	Lift adjusting lever and move seat forward or rearward.

ACCELERATOR AND BRAKE CONTROLS

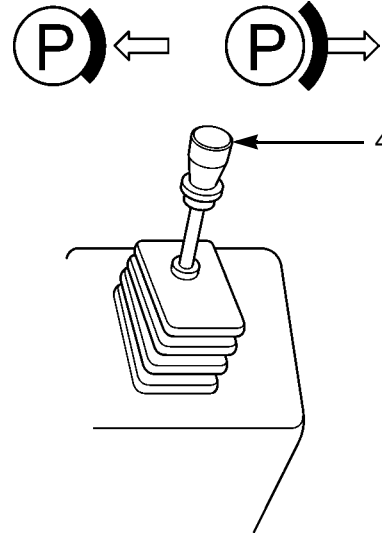
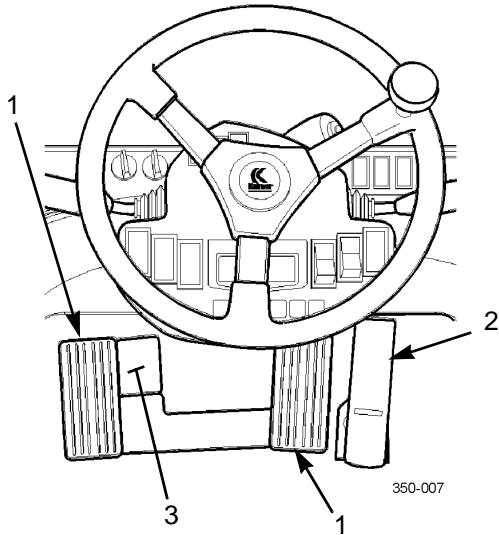

Key	Control or Indicator	Function
1	Service Brake Pedals	Depress to apply service brakes and illuminate brake lights.
2	Accelerator Pedal	Depress to increase engine speed; release to decrease engine speed. Pedal is electrically linked to the ECM.
3	Transmission Disconnect Brake Pedal	Depress to release internal transmission internal clutch. This allows the operator to increase engine RPM, thereby accelerating hydraulic functions.
4	Parking Brake Lever	Push lever forward to apply; raise collar on lever and pull to the rear to release. The parking brake should never be applied as an emergency brake or while the vehicle is moving. Application of the parking brake while the vehicle is moving can result in major drive train damage.

BOOM AND TOPHANDLER CONTROLS

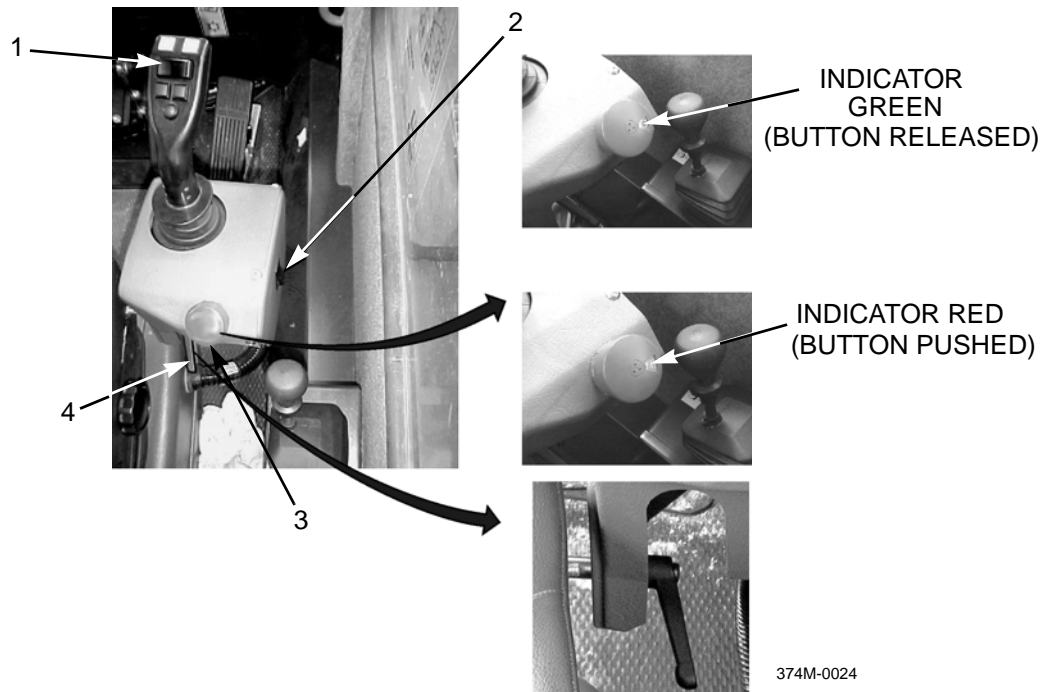

NOTE

Refer to *Operation Under Usual Conditions*, WP 0005 00, for detailed instruction on joystick operations.

Key	Control or Indicator	Function
1	Joystick	Provides the following electro-hydraulic controls: (a) Raises and lowers boom. (b) Extends and retracts boom. (c) Locks and unlocks twistlocks. (d) Extends and retracts tophandler spreader for 20 to 40 ft (6.10 to 12.19 m) containers. (e) Tilts and oscillates tophandler. (f) Locks container in position when tilted or oscillated. (g) Slews left and right. (h) Sideshifts left and right. (i) Straight lifting control.
2	Override Switch	Allows operator to retract and lower boom after an OVERLOAD lockout, provides twistlock override in the event of incorrect twistlock alignment, and allows raising the boom to be raised when tophandler is removed.
3	Emergency Stop Button	Push button to stop all hydraulic functions on boom and tophandler. When button is pushed, indicator on button shows red. Pull button to release. When released, indicator on button shows green. Activation of emergency stop button will cause the engine to decelerate to 1,000 RPM. It will be necessary to turn off engine and restart to clear the deceleration.
4	Joystick Positioning Lever	Raise to release lever and adjust joystick position. Lower lever to lock joystick in position.

BOOM AND TOPHANDLER CONTROLS - CONTINUED

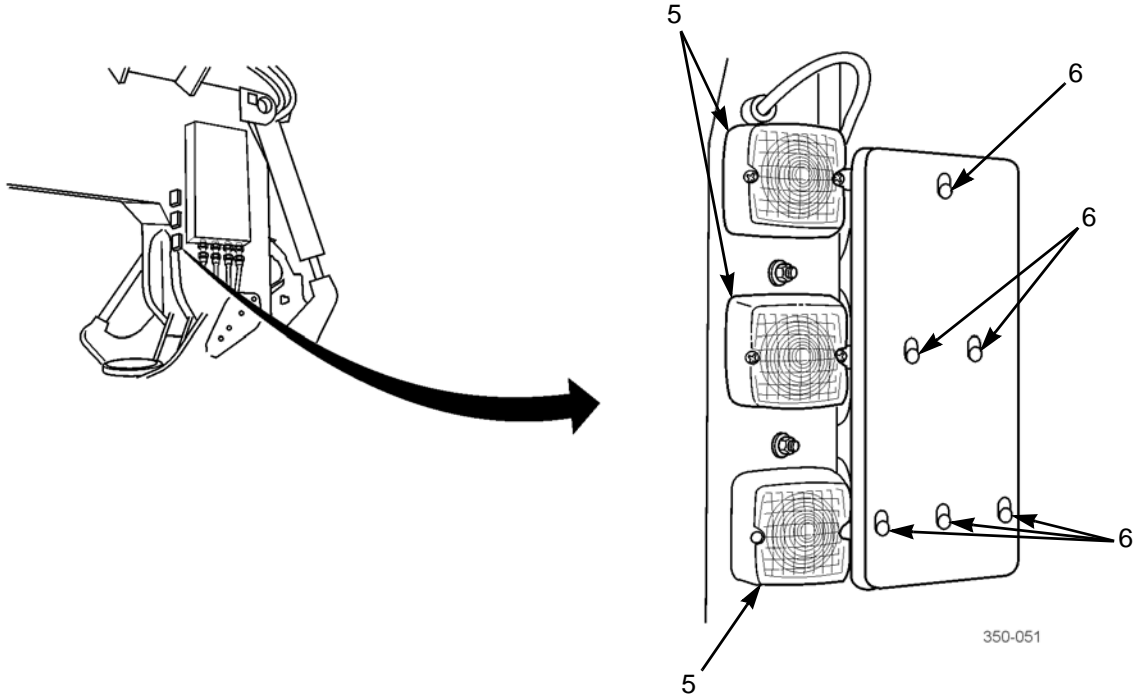

Key	Control or Indicator	Function
5	Twistlock Indicator Lights	RED: twistlocks UNLOCKED YELLOW: twistlock ALIGNING GREEN: twistlocks LOCKED
6	Twistlock Indicator Lights (IR)	Single IR light: twistlocks UNLOCKED Two IR lights: twistlock ALIGNING Three IR lights: twistlocks LOCKED

REMOTE HYDRAULIC CONTROLS

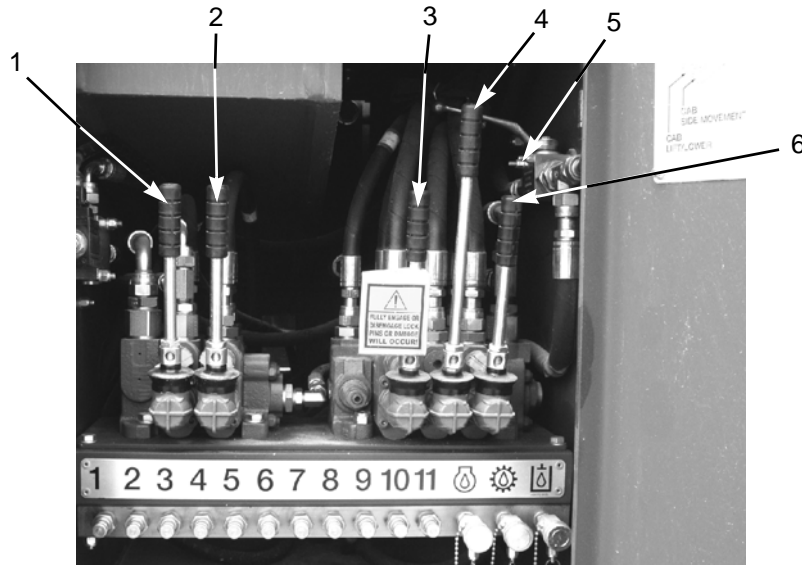

374M-0011

Key	Control or Indicator	Function
1	Cab Lift/Lower Lever	Used to move cab to transport position. Pull lever to raise cab. Push lever to lower cab.
2	Cab Side Movement Lever	Used to move cab to transport position. Pull lever to move cab to the left. Push lever to move cab to the right.
3	Locking Pins Lever	Pull lever to hydraulically extend/install boom support locking pins. Push lever to hydraulically retract locking pins.
4	Folding Boom Support Lever	Pull lever to hydraulically raise boom support. Push lever to hydraulically lower boom support.
5	Bogie Wheel Pressure Valve	Supplies constant pressure to bogie wheels during air transport.
6	Bogie Wheel Lever	Used to lower and raise bogie wheels. Pull lever to raise bogie wheels. Push lever to lower bogie wheels.

END OF WORK PACKAGE

OPERATION UNDER USUAL CONDITIONS

0005 00

THIS WORK PACKAGE COVERS

General	Operate Lifting Boom and Tophandler
Initial Adjustments, Dash Checks, and Self-Test	Operate Heater and Defroster
Start Engine	Operate Air Conditioner
Operate Transmission	Operate Lights, Horn, and Front Windshield Wipers/ Washer
Operate Parking Brake	Operate Portable Fire Extinguisher
Steering	Forklift Kit Installation
Driving Tips	Parking and Positioning for Short- and Long- Term Storage
Driving	

INITIAL SETUP

Personnel Required

Two

References

WP 0004 00

WP 0006 00

References - Continued

WP 0007 00

WP 0012 00

WP 0013 00

WP 0020 00

GENERAL

NOTE

- **This vehicle has been designed to operate safely and efficiently within the limits specified in this TM.**
- **If an error code appears on driver’s ECS display screen during operation, refer to WP 0020 00 for further information.**

This section contains instructions for safely operating the RTCH-RT 240V2 under usual conditions. Unusual conditions are defined and described in WP 0006 00.

INITIAL ADJUSTMENTS, DAILY CHECKS, AND SELF-TEST**NOTE**

Refer to WP 0004 00 for location and operation of controls.

1. Place master battery switch in ON position.

MASTER BATTERY SWITCH
(SHOWN IN OFF POSITION)

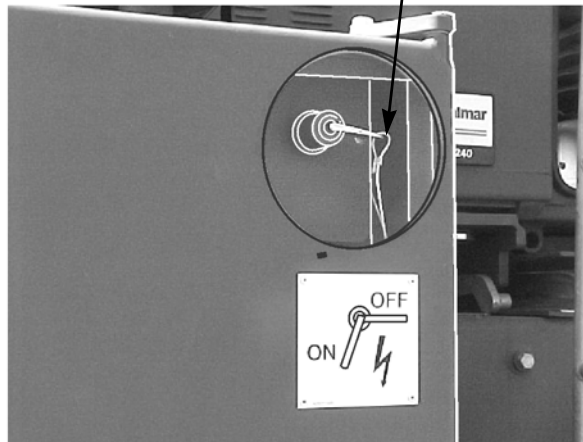

350-048

2. Perform *Before* operation Preventive Maintenance Checks and Services (PMCS) (WP 0012 00 and WP 0013 00).
3. Occupy and adjust seat.

NOTE

Vehicle should not be operated with cab door open.

4. Close cab door.
5. Adjust position of joystick.
6. Adjust left and right exterior mirrors and interior rearview mirror as required.
7. Adjust steering wheel and column.
8. Fasten seat belt.

START ENGINE**NOTE**

Refer to WP 0004 00 for location and operation of instrument panel indicators and controls.

1. Ensure parking brake is applied.
2. Place transmission shift control lever in Neutral (N).
3. Ensure all accessory switches and controls are in the OFF position.

CAUTION

DO NOT operate the starter motor for more than 30 seconds at a time. After 30 seconds, allow starter motor to cool for at least 2 minutes before attempting to start engine again. Excessive heating of starter motor may result in damage or early starter failure.

4. Turn ignition switch to ON position. System warning lights will illuminate briefly, then go out.
5. If ambient temperature is below 32°F (0°C), press ether injector switch on instrument panel.

NOTE

Start the engine with throttle in the IDLE position. It is not necessary to press the throttle to start a computer-controlled engine.

6. Turn ignition switch to START and allow the engine to start and run at idle speed.
7. Increase the engine speed (RPM) slowly to provide adequate lubrication to the bearings and allow the oil pressure to stabilize.
8. Run engine at idle speed for 3 to 5 minutes before operating with a load.
9. Monitor fuel gage and indicators for any signs of abnormal temperatures or pressures. Shut down engine at first sign of a problem.

OPERATE TRANSMISSION1. **Transmission Ranges.**

- a. **Forward (F).** When placed in Forward (F), the transmission starts out in 1st gear and automatically progresses to the 4th gear. Automatic gear changing can be limited by rotating the gear selection lever to 3rd, 2nd, or 1st gear. The current gear selection and direction will be displayed on the driver's ECS display screen.
- b. **Neutral (N).** This is the normal transmission position when the machine is not in use. Use N when starting the engine, checking accessories, and for extended periods of idling. An N will be displayed on the driver's ECS display screen when transmission is in the Neutral position.
- c. **Reverse (R).** When placed in Reverse (R), the RTCH moves backwards; the transmission starts out in 1st gear and automatically progresses to the 3rd reverse gear. The current gear selection and direction will be displayed on the driver's ECS display screen.

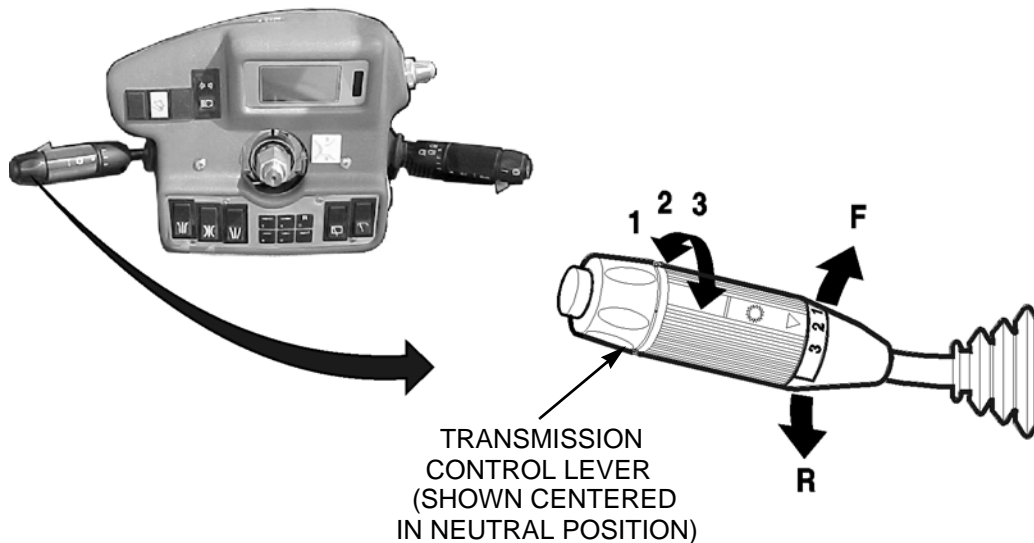

434-20007

2. **Operation.****CAUTION**

ALWAYS bring the RTCH to a complete STOP before changing from Forward (F) to Reverse (R) to prevent possible damage to the transmission.

NOTE

When a lower transmission range or gear is selected, the transmission may not downshift until vehicle speed is reduced.

- a. Depress and hold brake pedal.
- b. Release parking brake.
- c. Select direction and gear range with transmission control lever.
- d. Release brake pedal and begin to move RTCH.
- e. As required, select a specific forward or reverse gear for the load.

OPERATE PARKING BRAKE**WARNING**

Never leave the operator's position without applying the parking brake. Failure to follow this warning may result in injury or death to personnel or damage to equipment.

CAUTION

The parking brake should never be applied as an emergency brake or while the vehicle is moving. Application of the parking brake while the vehicle is moving can result in major drive train damage.

NOTE

A buzzer will sound if the driver attempts to leave the driver's seat without first applying the parking brake.

1. Push the parking brake lever forward to engage the parking brakes at front and rear axles. Raise release collar and pull the lever backward to release the parking brakes.

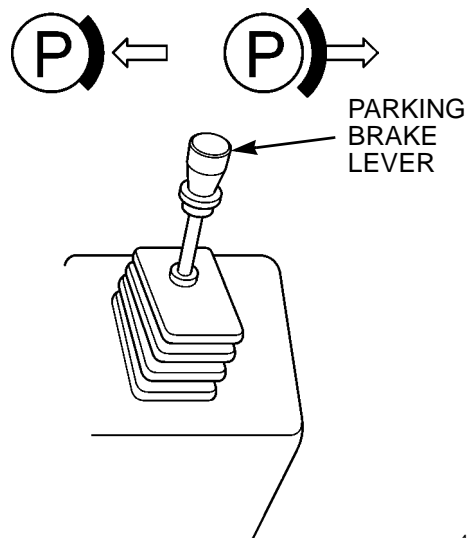

434-10004

2. A RED indicator light will illuminate on the instrument panel when the parking brake is applied.

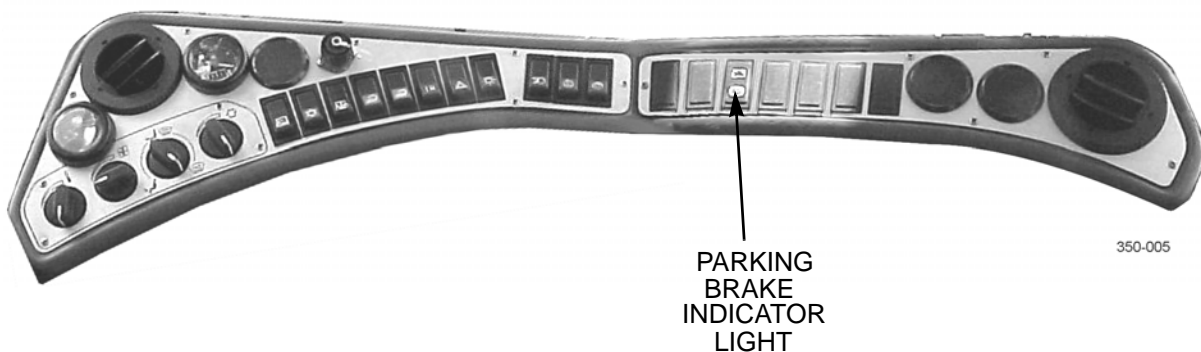







350-005

STEERING

1. **Steering Modes.**

- a. The RTCH-RT 240V2 can be operated in any of three steering modes: 2-wheel, 4-wheel, or crab steering, as selected by the steering mode selection switches. Position wheels straight ahead and place transmission in Neutral (N).
- b. Always bring the RTCH to a complete stop before switching from one steering mode to another.
- c. Emergency steering is provided by the emergency ground-driven steering pump. If the engine quits during operation, this pump provides sufficient hydraulic pressure to control the RTCH until it is brought to a safe stop.

Gear Lever	Steering programs		
	Forward 	Four 	Crab 
F3	2-3-4	1-2-3	2
F2	2-3	1-2	1-2
F1	2	1	1
R1	2	1	1
R2	2	1-2	1
R3	2-3	1-2-3	1
			

1 Not loaded vehicle

350-057

- 2. **2-wheel Steering.** Press the 2-wheel steering selection switch on the steering column. Front wheels will steer in the direction the steering wheel is turned; the rear wheels will remain in the forward position.

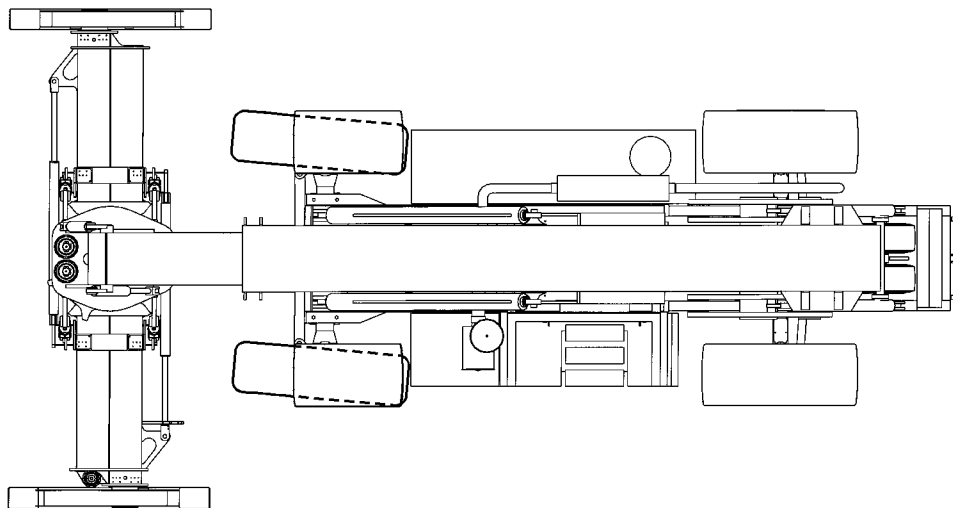

434-20001

STEERING - CONTINUED

3. **4-wheel Steering.** Press the 4-wheel steering selection switch on the steering column. Front wheels will steer in the direction the steering wheel is turned, the rear wheels will steer in the opposite direction. This steering mode allows for an extremely short turning radius. It also enables the rear wheels to follow in the tracks of the front wheels, thereby increasing traction in mud and snow conditions.

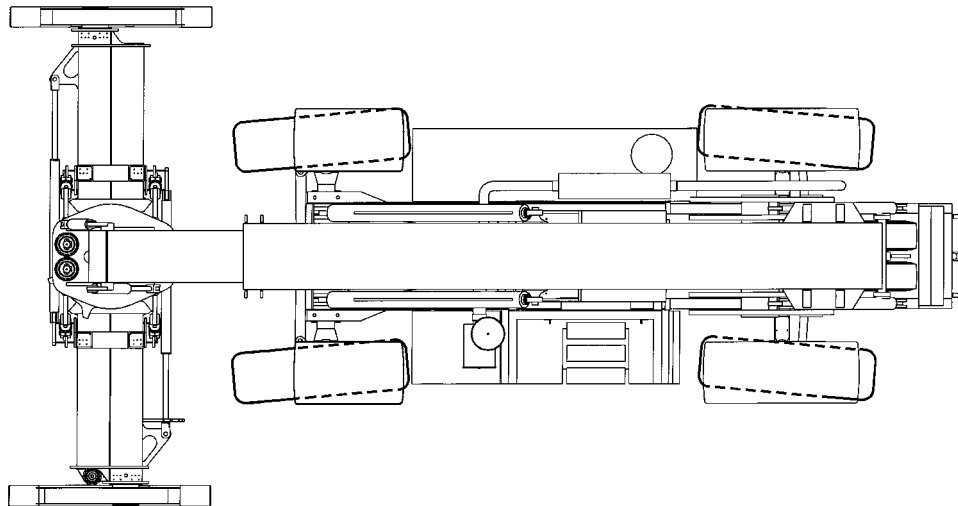

434-20002

4. **Crab Steering.** Press the crab steering selection switch on the steering column. All wheels will steer in the same direction. This steering mode permits sideways movement for better positioning of the RTCH during transport and moving the RTCH within tight quarters.

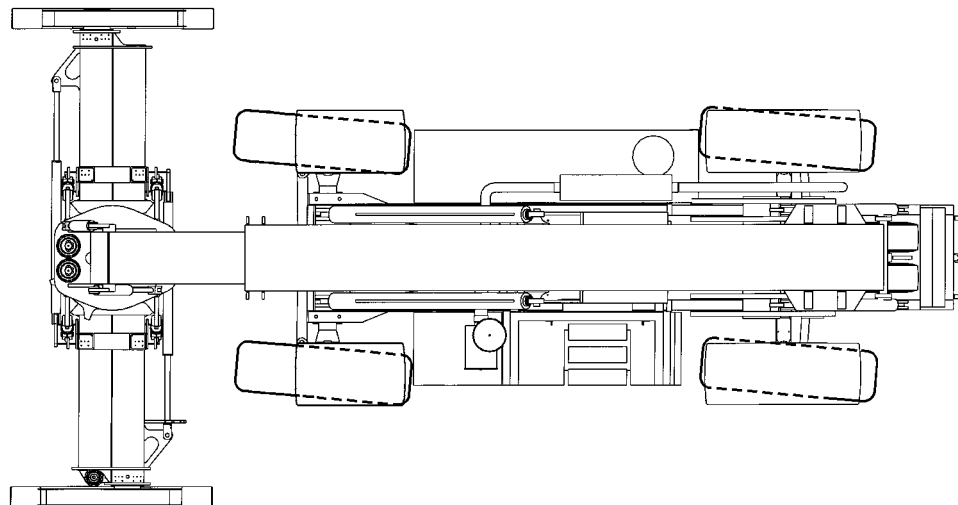

434-20003

DRIVING TIPS**WARNING**

- **DO NOT allow riders on the vehicle. Failure to follow this warning may result in serious injury or death to personnel.**
- **Vehicle must not be driven when container load is in fully raised position. Vehicle is less stable when traveling with the load in a raised position. Always position the bottom of the load just above the driver's field of view, with the boom fully retracted. Failure to follow this warning may result in serious injury or death to personnel.**
- **BE ALERT for personnel in area while operating vehicle. Always check to ensure area is clear of personnel and obstructions before moving. Failure to follow this warning may result in serious injury or death to personnel.**

CAUTION

The governed engine speed is 2,100 RPM. If engine is allowed to exceed governed speed, serious engine or transmission damage may result.

1. **Check Fuel Gage, Indicators, and ECS Display Screen Frequently.** If indicators show an abnormal reading or warning light comes on, bring RTCH to a safe stop, shut down engine, and investigate cause.
2. **Avoid Oversteering.** Become familiar with steering characteristics of the RTCH before attempting maneuvers in limited space.
3. **Avoid Hard Braking.** Become familiar with the braking characteristics of the RTCH with and without a load.
4. **Proper Carry Position.** When driving without a load, position the tophandler above your field of view, with the boom fully retracted. When driving with a load, position the bottom of the load above your field of view, with the boom fully retracted.
5. **Maximum Driving Slopes.** Do not drive the RTCH on a side slope in excess of 15 percent (8.5 degrees) with or without rated load. The maximum slope for driving up or down a grade must not exceed 27 percent (15 degrees) with or without rated load at 4 mph (6 kph) or less.

DRIVING**NOTE**

Refer to WP 0004 00 for location and operation of controls.

1. Perform initial seat and steering column adjustments.
2. Perform daily checks and self-tests (WP 0013 00).
3. Start engine and allow it to come up to operating temperature.
4. Raise tophandler to driving position.
5. With engine at idle, apply service brakes.
6. Select steering mode of operation by first straightening wheels, then pressing desired steering selection switch.
7. Move transmission control lever to desired direction, F or R, and select gear range.
8. Release parking brake lever and depress accelerator pedal to control machine speed.
9. Engage oscillation and tilt locks before driving with a load.

OPERATE LIFTING BOOM AND TOPHANDLER

NOTE

- **DO NOT** perform container handling procedures while in blackout mode. Blackout mode is to be used only when driving. In blackout mode, oscillation and tilt lock/unlock buttons do not illuminate. However, these buttons will light up in service mode or when IR lights are on. With IR lights on, container handling is permissible with proper night vision equipment.
- Refer to *Operation Under Unusual Conditions*, WP 0006 00, for instructions on emergency lowering of the boom in the event of engine shutdown.

1. **General.**

- a. It is essential that the operator know how to safely perform every RTCH container handling operation.
- b. The following information will provide the operator with instructions to perform container handling operations using the joystick to maneuver the lifting boom, tophandler, and forklift kit.
- c. The RTCH-RT 240V2 tophandler is designed to move, stack, and unstack 20 to 40 ft (6.10 to 12.19 m) ISO containers.
- d. With the forklift kit installed on the tophandler, the tophandler spreader controls will open and close the fork tines.
- e. The RTCH-RT 240V2 ECU continuously monitors the boom angle, boom extension, and pressure in the hydraulic lift cylinders. From this data, the computer calculates the actual load. This information is compared to the allowed load at the current position. When 100 percent capacity is reached, the system cuts off and will not allow any more movement, except to retract. When the load is moved into a safe operating range, system control is returned to the operator controls (joystick).
- f. During lifting operations, **DO NOT** exceed maximum lifting capability. The following chart indicates lift capacity in relation to inches of boom extension. Note that as the boom is extended, the lift capacity is reduced.

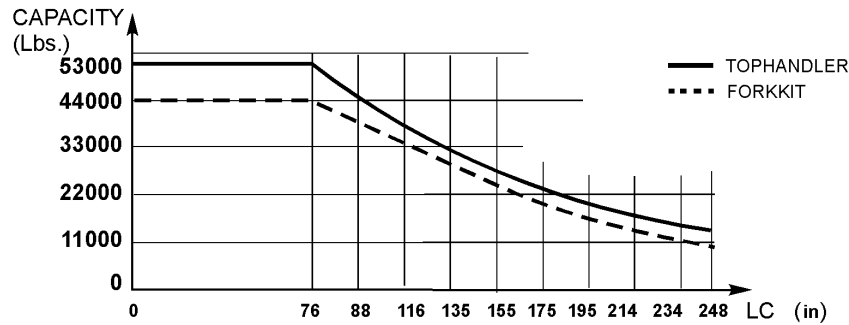

350-074

OPERATE LIFTING BOOM AND TOPHANDLER - CONTINUED2. **RTCH Operating Characteristics and Information.**

- a. The transmission will shift to neutral automatically if the container is not lifted off the ground before trying to drive. The following pop-up icon will display during this condition. Pressing “R” (Reset) will delete the icon from the display. The container must be lifted off the ground before the transmission will re-engage.

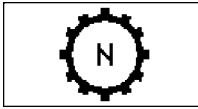

- b. If the tophandler is not in the proper carry position (with or without a container), the maximum forward travelling speed will be reduced to 7 mph (11 kph). The proper carry position without a container is the tophandler positioned just above your field of view. With a container, the proper carry position is with the bottom of the container positioned just above your field of view. The maximum travel speed in reverse for any boom position is limited to 7 mph (11 kph).
- c. To minimize damage from boom, tophandler, and container contact, the tophandler rotation is limited to 40 degrees clockwise or counterclockwise from the operational position if the boom angle is above 15 degrees. The full rotation of 105 degrees clockwise or 40 degrees counterclockwise can be obtained if the boom angle is under 15 degrees. The lift function will be stopped at 15 degree boom angle if lifting a tophandler that is rotated more than 40 degrees clockwise. The following pop-up icon will display during this condition. Pressing “R” (Reset) will delete the icon from the display.



- d. When the tophandler is rotated more than 40 degrees clockwise, the tilt “bottom in” function is limited. The tilt function is controlled in order to reduce the possibility of boom and tophandler contact. The following pop-up icon will display during this condition. Pressing “R” (Reset) will delete the icon from the display.



- e. To aid in the engagement of the tophandler into a container, the following pop-up icon will display. This icon indicates when each corner of the tophandler has seated in the container. When all four corners have seated, the icon disappears from the display. Pressing “R” (Reset) will delete the icon from display.

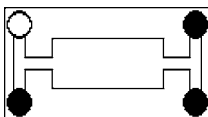

OPERATE LIFTING BOOM AND TOPHANDLER - CONTINUED

3. **Joystick Operation.** Buttons and switches on the joystick are used, individually or in conjunction with each other, to fully control all container handling operations. The following decal, located on the cab's right-side window, summarizes all joystick functions.

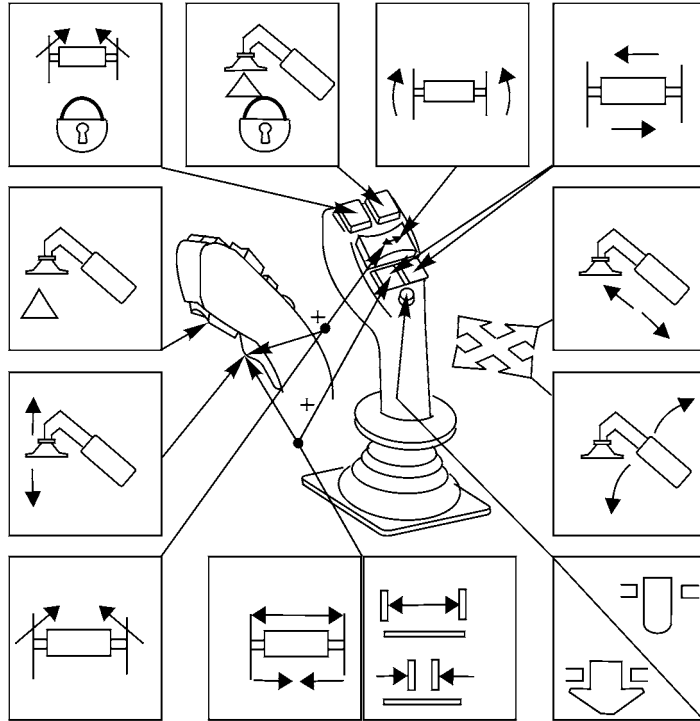

374M-058

a. Oscillation Lock/Unlock Button.

NOTE

Button illuminates when lock is engaged.

- (1) Press to engage lock, securing load position.
- (2) Press to release lock, allowing load to float.

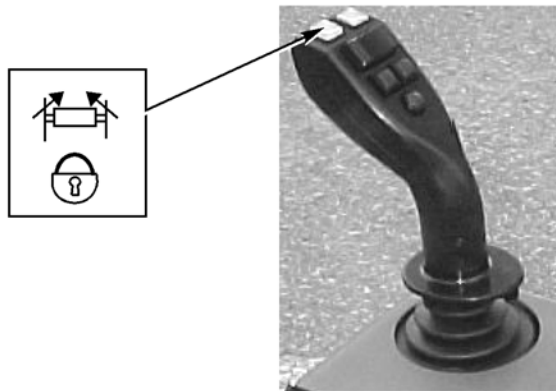

350-060

OPERATE LIFTING BOOM AND TOPHANDLER - CONTINUED**b. Tilt Lock/Unlock Button.****NOTE****Button illuminates when lock is engaged.**

- (1) Press to engage lock, securing load position.
- (2) Press to release lock, allowing load to float.

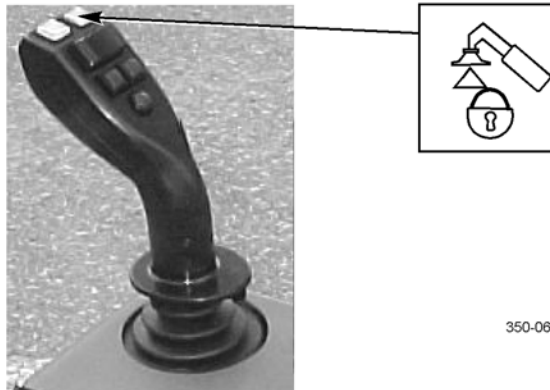
**c. Rotation Control Rocker Switch.**

- (1) Press left side of rocker switch to rotate load clockwise.
- (2) Press right side of rocker switch to rotate load counterclockwise.

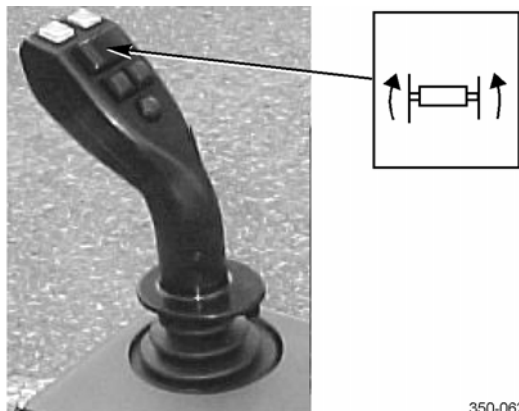

OPERATE LIFTING BOOM AND TOPHANDLER - CONTINUED

d. Tophandler and Forklift Sideshift Buttons.

- (1) Press right button to shift load to the right.
- (2) Press left button to shift load to the left.

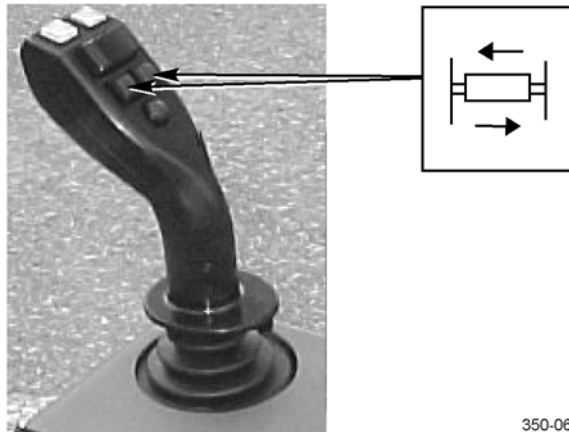

350-063

- (3) Press right button and multi-function trigger button to widen tophandler from 20 to 40 ft (6.10 to 12.19 m) or to open forklift tines, if forklift kit is installed.

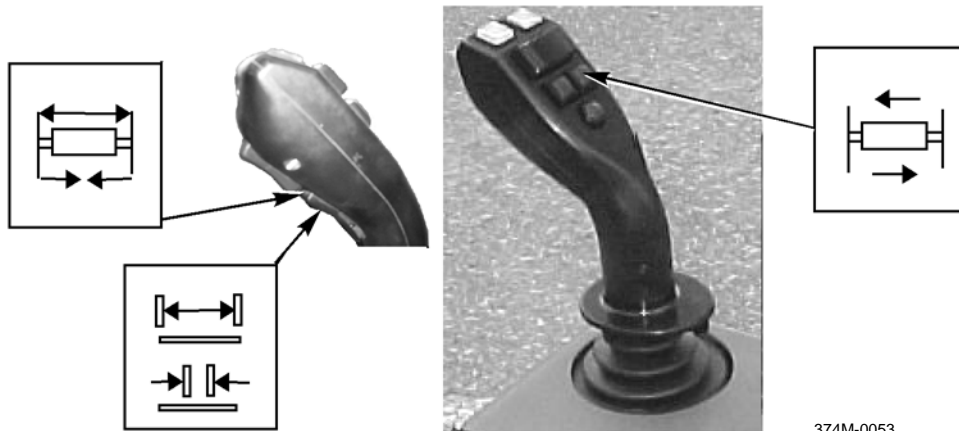

374M-0053

OPERATE LIFTING BOOM AND TOPHANDLER - CONTINUED

- (4) Press left button and multi-function trigger button to close tophandler from 40 to 20 ft (12.19 to 6.10 m) or to close forklift tines, if forklift kit is installed.

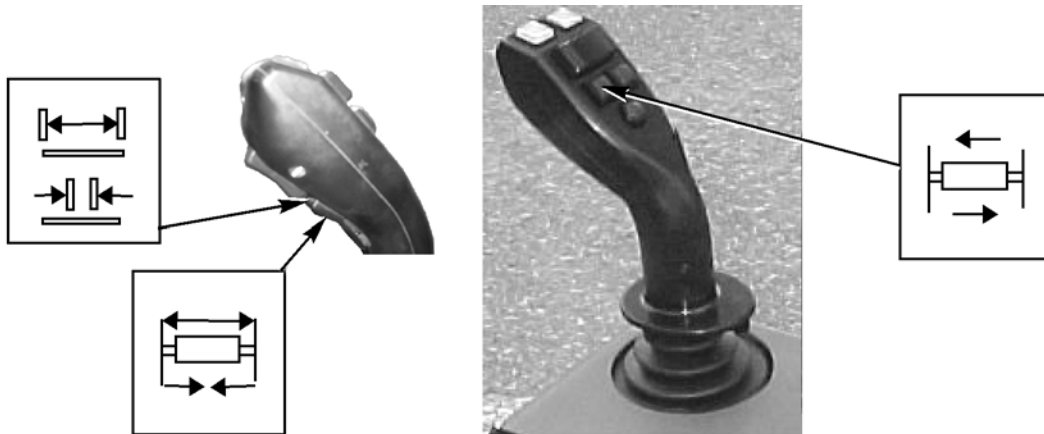

374M-0054

e. Twistlock Lock/Unlock Button.

NOTE

- When twistlocks are locked, GREEN indicator light on steering column inside cab and at end of boom will illuminate. Three IR lights at end of boom also illuminates when operating in blackout mode.
- When twistlocks are unlocked, RED indicator light on steering column inside cab and at end of boom will illuminate. Single IR light at end of boom also illuminates when operating in blackout mode.
- Press twistlock lock/unlock button and override switch at the same time to lock out or disable boom lifting and lowering operation. Twistlock indicator light will turn off. To reactivate boom, press twistlock lock/unlock button and override switch at the same time.

- (1) Press button to lock twistlocks, securing load.
- (2) Press button to unlock twistlocks, releasing load.

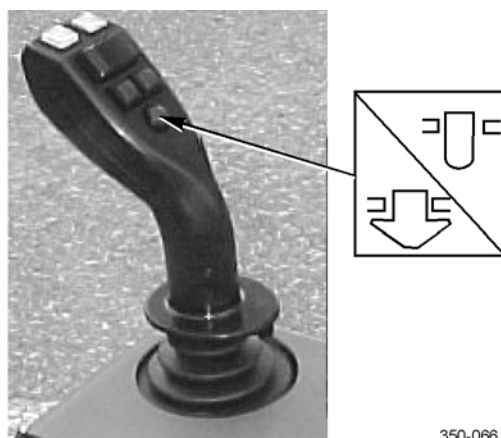

350-066

OPERATE LIFTING BOOM AND TOPHANDLER - CONTINUED**f. Boom Control Joystick.**

- (1) Move joystick forward to lower boom.
- (2) Move joystick back to raise boom.
- (3) Move joystick right to extend boom.
- (4) Move joystick left to retract boom.

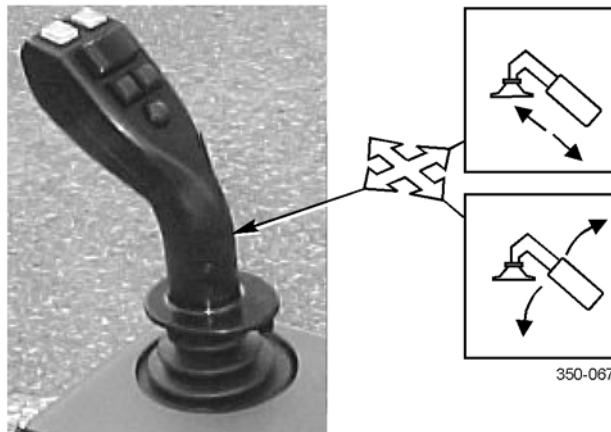
**g. Tilt Control Rocker Switch.**

- (1) Press bottom of rocker switch to tilt bottom of load in.
- (2) Press top of rocker switch to tilt bottom of load out.

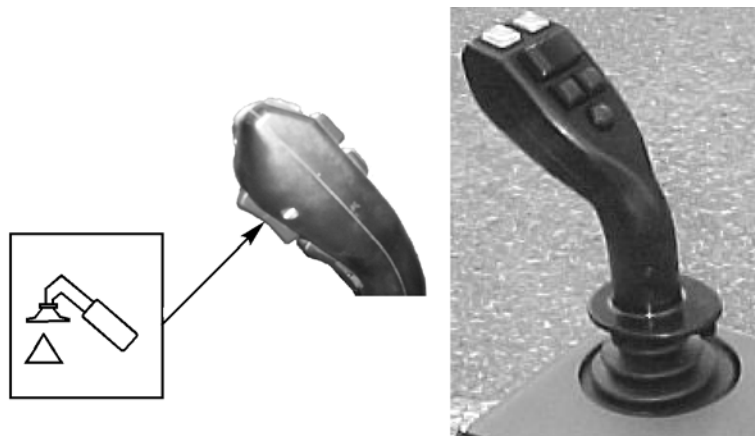

OPERATE LIFTING BOOM AND TOPHANDLER - CONTINUED

h. Oscillation Control Switches.

- (1) Press multi-function trigger button and right side of rotation control rocker switch to raise left side of load.
- (2) Press multi-function trigger button and left side of rotation control rocker switch to raise right side of load.



374M-0056

i. Straight Lift/Lower Controls.

- (1) Move joystick back while pressing multi-function trigger button to raise and extend boom.
- (2) Move joystick forward while pressing multi-function trigger button to lower and retract boom.

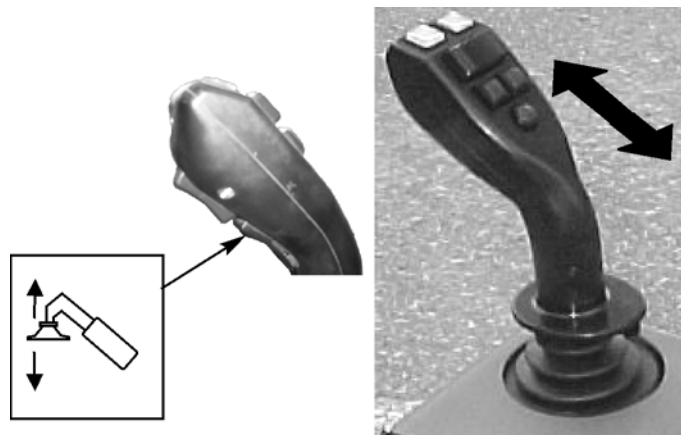

374M-0057

OPERATE LIFTING BOOM AND TOPHANDLER - CONTINUED**j. Override Switch.****NOTE**

Press twistlock lock/unlock button and override switch at the same time to lock out or disable boom lifting and lowering operation. Twistlock indicator light will turn off. To reactivate boom, press twistlock lock/unlock button and override switch at the same time.

- (1) Move joystick forward while pressing override switch to lower the boom in an override condition.
- (2) Press override switch to override twistlock alignment, locked, or unlocked signals.
- (3) Press override switch to raise boom with tophandler removed.

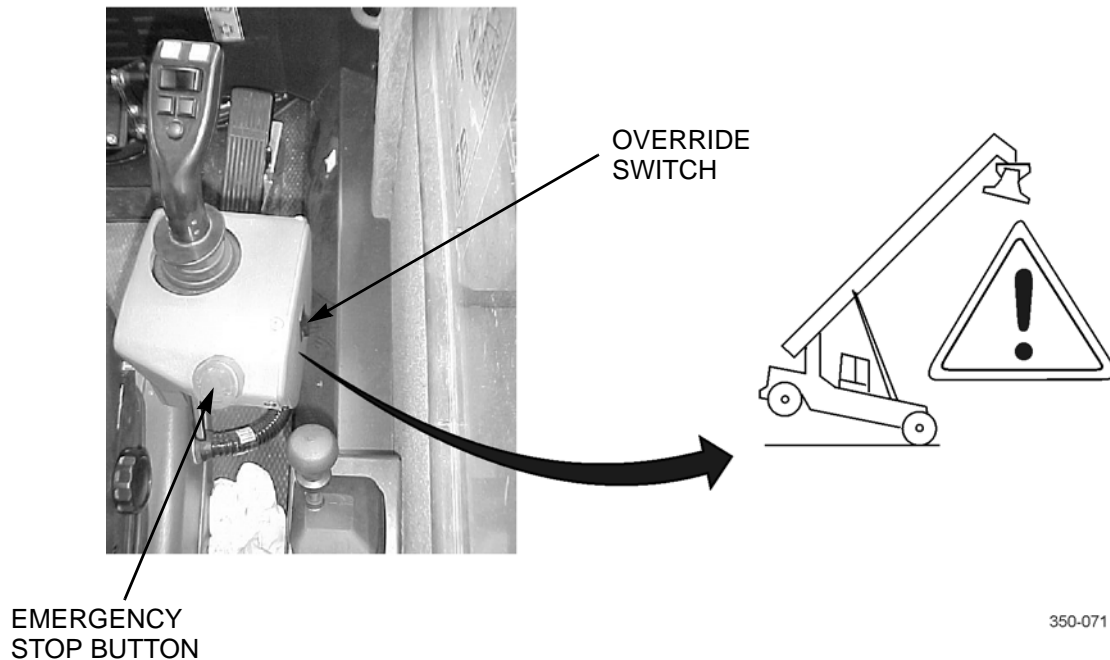
**k. Emergency Stop Button.**

- (1) Press button to stop all boom and tophandler hydraulic functions.

NOTE

- **Activation of the emergency stop button will cause the engine to decelerate to 1,000 RPM. It will be necessary to turn off engine and restart to clear deceleration.**
- **Be sure to release emergency stop button when resuming normal operation. If emergency stop button is left activated, error codes may appear on driver's ECS display screen.**

- (2) Pull button to release emergency stop button.

OPERATE LIFTING BOOM AND TOPHANDLER - CONTINUED4. **Container Lifting.****WARNING**

NEVER operate the RTCH or move the load near a power line or overhead wires. Failure to follow this warning may result in death or injury to personnel or damage to equipment.

- a. Adjust the tophandler spreader width 20 to 40 ft (6.10 to 12.19 m) for the container to be lifted.
- b. Position the RTCH as close to the container as possible. Adjust the tophandler to the container by rotating, sideshifting, or moving the boom as necessary.
- c. Fully lower the tophandler while aligning the twistlocks with the container locking holes. Make sure the float locks are released (unlocked) when lowering into container locking holes.
- d. Ensure YELLOW alignment indicator light is on. This indicates the twistlocks are engaged in the locking holes of the container.
- e. Lock the twistlocks. Ensure GREEN lock indicator light is on.
- f. Lift the load. When load is lifted, the YELLOW alignment indicator light will go out.
- g. Raise the container above your field of view, then fully retract. This will place the container in the proper carry position.
- h. Engage oscillation and tilt locks before driving with a load over rough terrain.

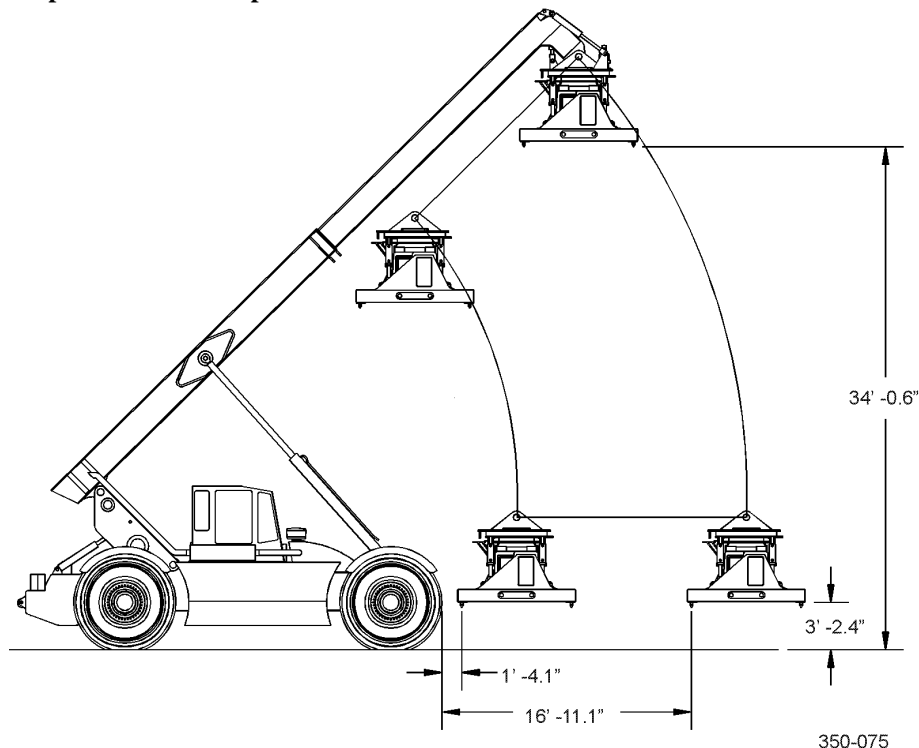
5. **Tophandler Positioning.**a. **Tophandler Operational Envelope.**

OPERATE LIFTING BOOM AND TOPHANDLER - CONTINUED

b. Tophandler Shifting and Rotating Positions.

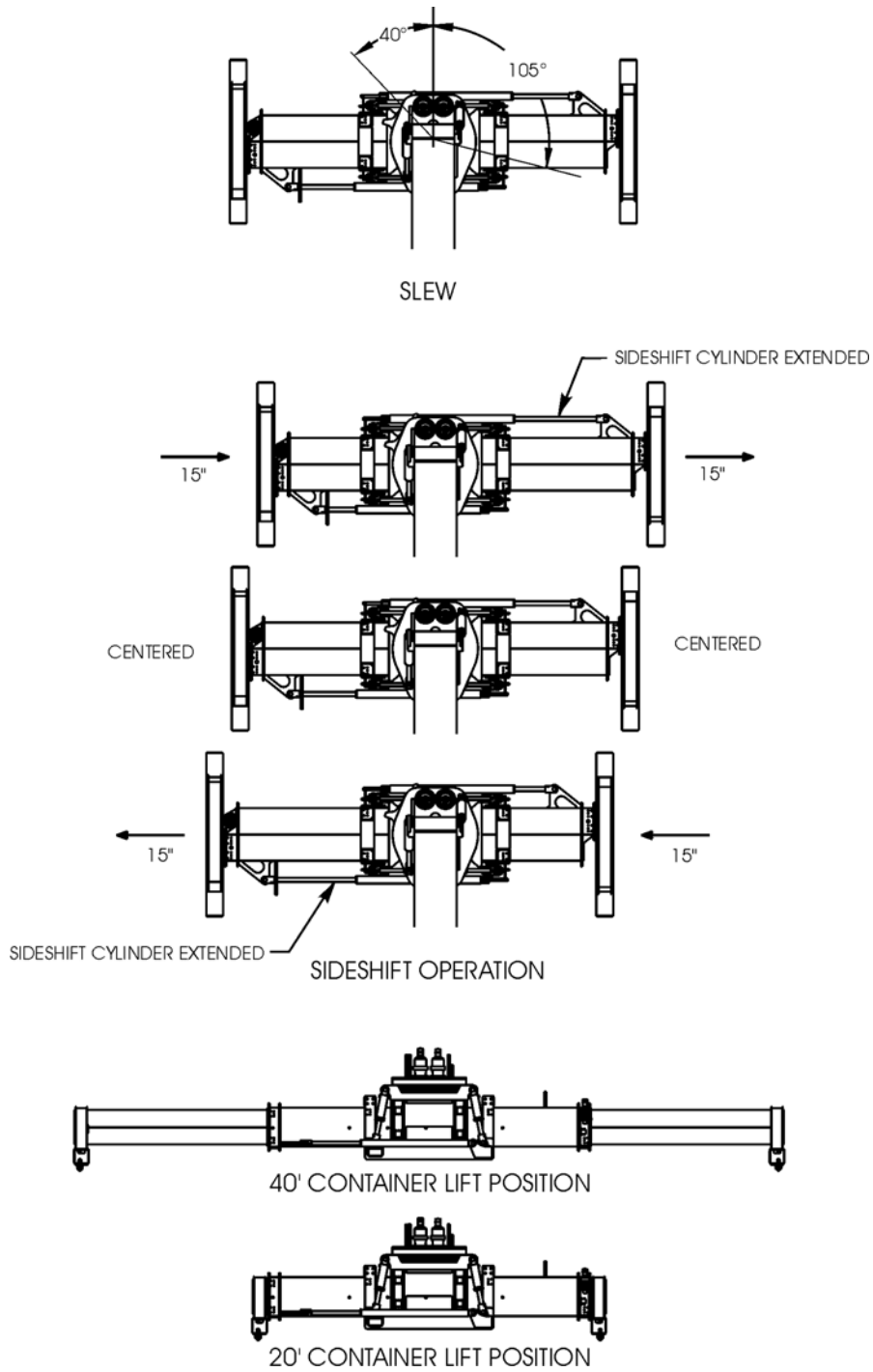

350-076

OPERATE LIFTING BOOM AND TOPHANDLER - CONTINUED

6. **Container Positioning.**

a. **Lifting and Centering 20 or 40 ft (6.10 or 12.19 m) Containers.**

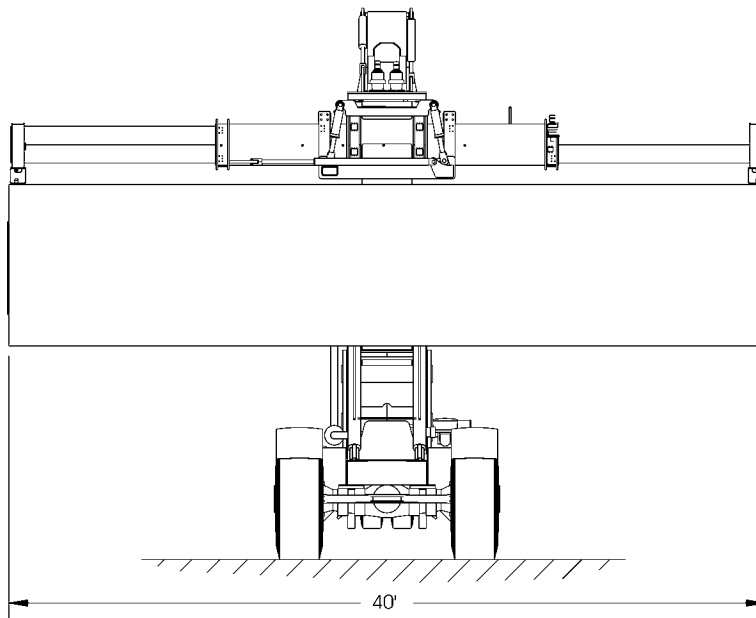
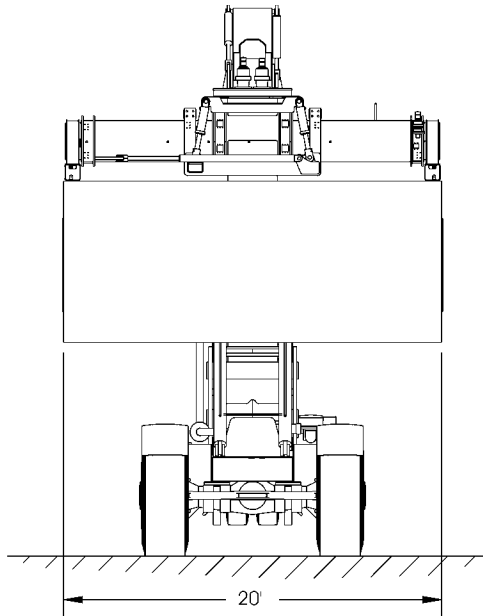

OPERATE LIFTING BOOM AND TOPHANDLER - CONTINUED

b. Container Oscillation and Tilt Angles.

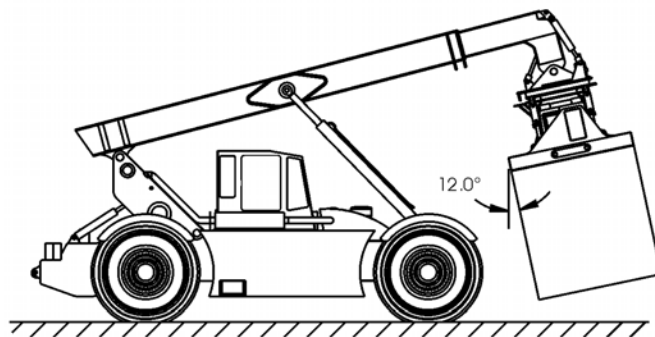
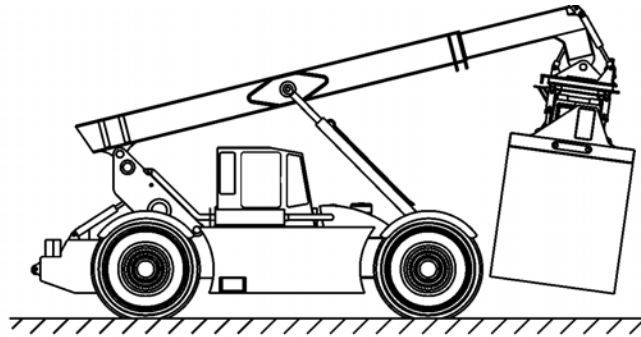

TILT ANGLES

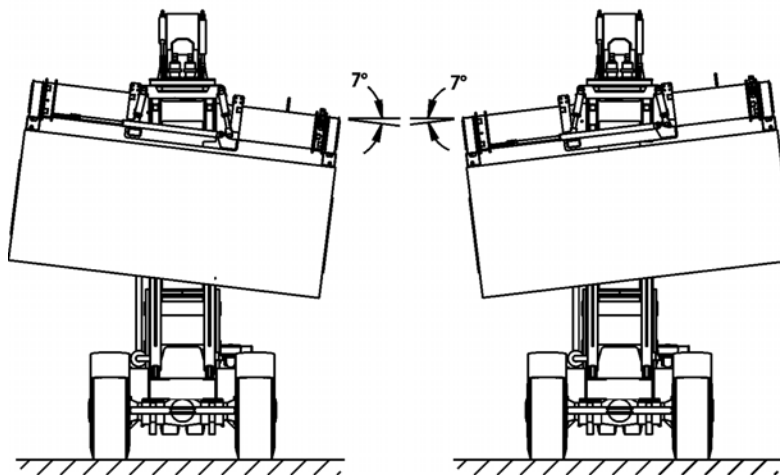

OSCILLATION ANGLES

350-078

OPERATE LIFTING BOOM AND TOPHANDLER - CONTINUED

- c. Container Reach and Load Range in Row One, 53,000 lb (24,040 kg), and in Row Two 27,500 lb (12,474 kg).

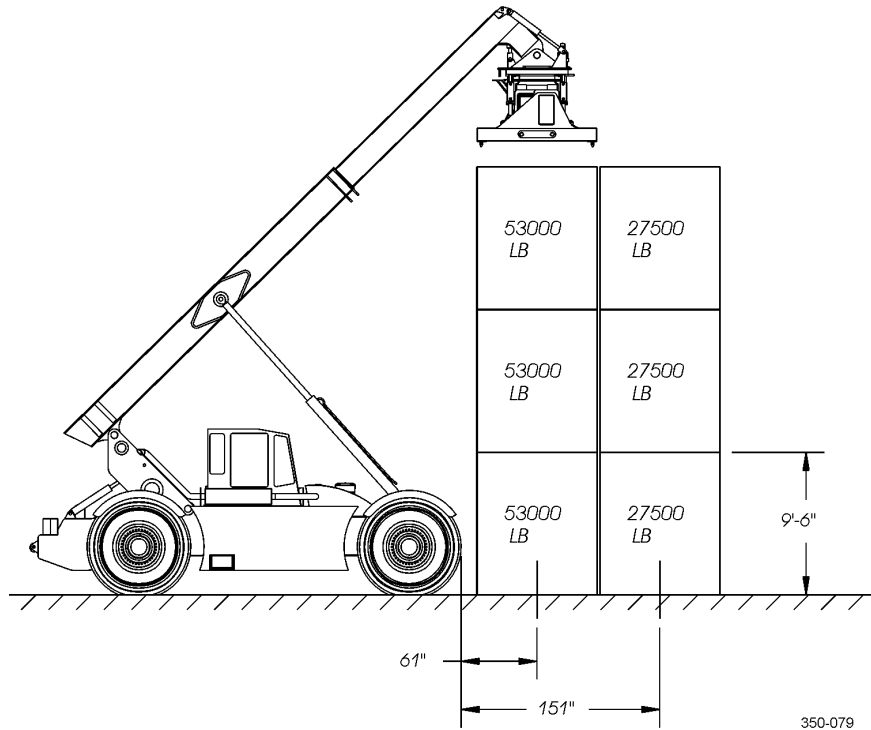

OPERATE LIFTING BOOM AND TOPHANDLER - CONTINUED

d. Stacking of 4 ft 3 in. (1.30 m) Containers Seven High.

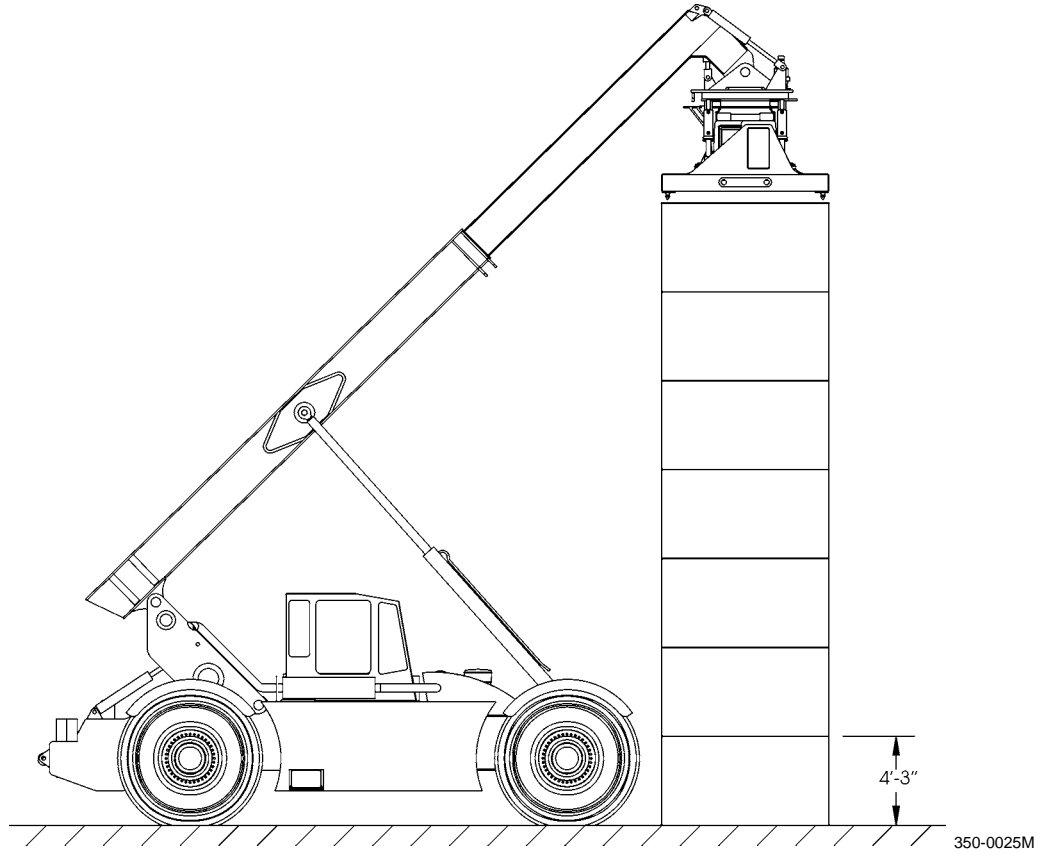

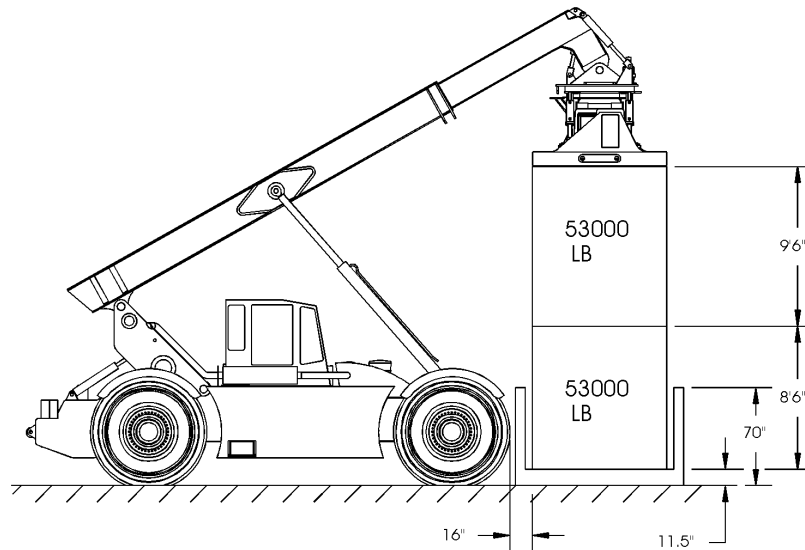
OPERATE LIFTING BOOM AND TOPHANDLER - CONTINUED**e. Deep Well Container Lifting/Stacking.**

350-081

OPERATE HEATER AND DEFROSTER

1. Start engine and bring RTCH to normal operating temperature.
2. Rotate heater and defroster selection switch clockwise to desired position to select airflow direction to windshield, operator, or both.
3. Rotate heater temperature control switch clockwise to desired position to control heater output within the cab.
4. Rotate fan switch clockwise to adjust fan speed from low to high.
5. Press cab air circulation control switch to select either recirculated or fresh air within the cab.

NOTE

Air vents are located at each rear corner of cab, as well as on instrument panel.

6. Control airflow as needed by adjusting louvered openings of air vents.

OPERATE HEATER AND DEFROSTER - CONTINUED

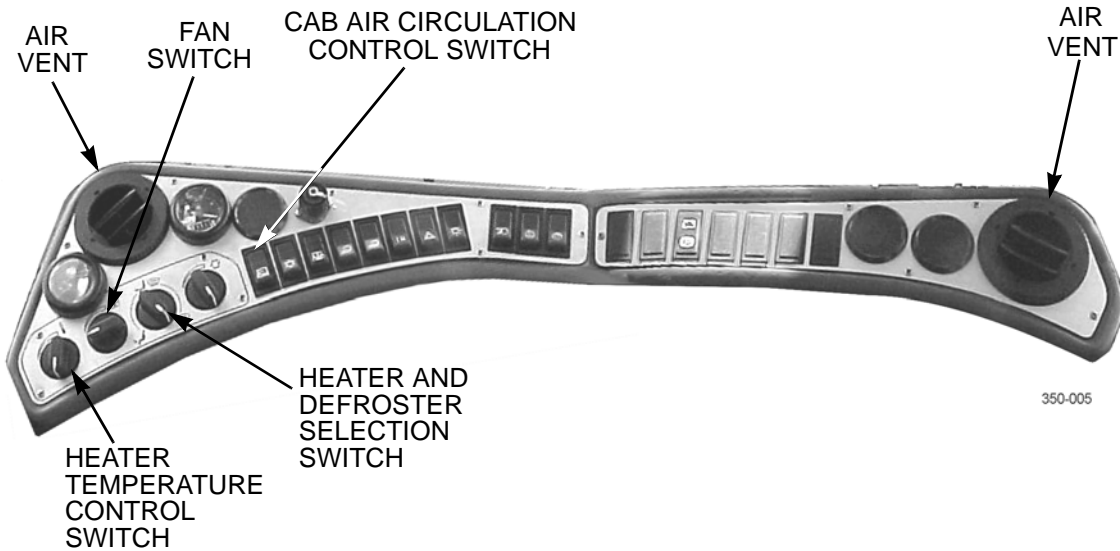

OPERATE AIR CONDITIONER

1. Start engine and bring RTCH to normal operating temperature.
2. Press air conditioning control switch to the ON position.
3. Rotate air conditioner temperature control switch clockwise to desired position to control air conditioner output within cab.
4. Rotate fan switch clockwise to adjust fan speed from low to high.
5. Press cab air circulation control switch to select either recirculated or fresh air within the cab.

NOTE

Air vents are located at each rear corner of cab, as well as on instrument panel.

6. Control airflow as needed by adjusting louvered openings in air vents.

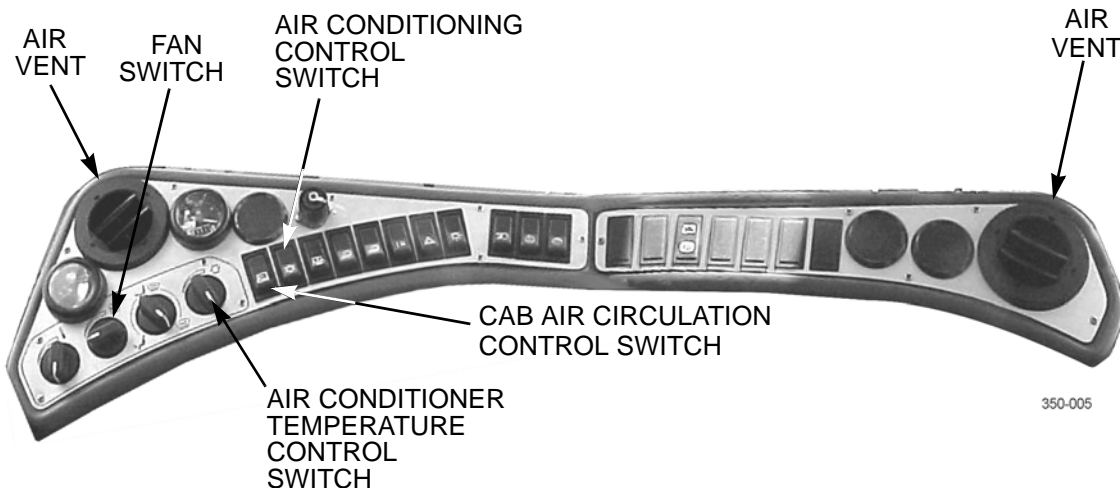

OPERATE LIGHTS, HORN, AND FRONT WINDSHIELD WIPER/WASHER**NOTE**

If the engine is not running, ignition switch must be in ON position for the lights and horn to work.

1. Place ignition switch in the ON position.
2. Move accessory control lever FORWARD for LEFT directional signal and REARWARD for RIGHT directional signal.
3. Lift up on accessory control lever to FLASH headlights.
4. Push down on accessory control lever for HIGH BEAM headlights.
5. Press button at the end of the accessory control lever for HORN operation.
6. Rotate accessory control lever knob for front windshield wiper and push for windshield washer functions.

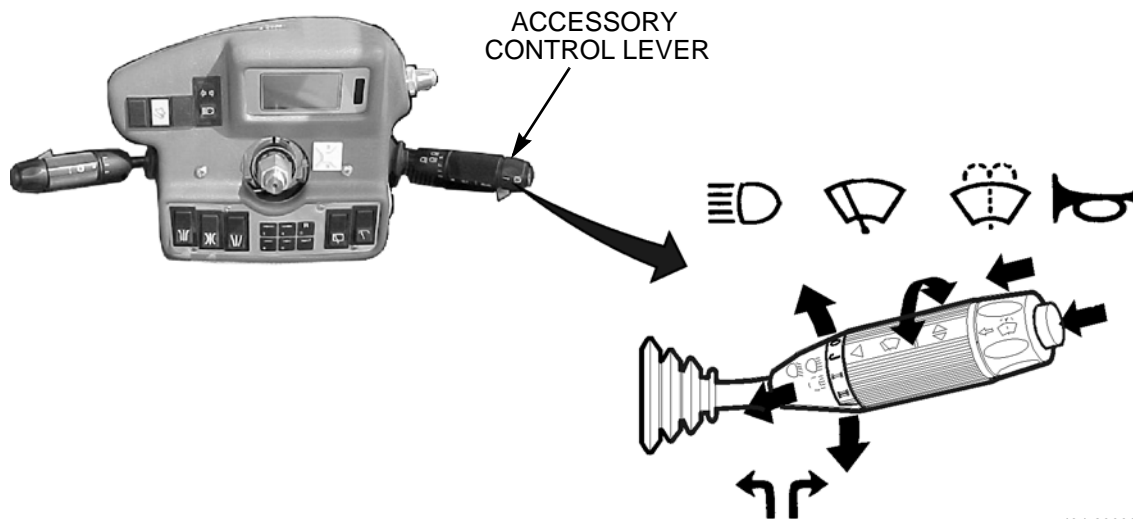

434-20006

SHUT DOWN ENGINE

1. Apply the parking brake.
2. Retract and fully lower boom.
3. Place transmission control lever in Neutral (N).
4. Allow the engine to run for 1/2 to 1 minute at idle.

CAUTION

DO NOT turn master battery switch to OFF when the engine is running. Damage to voltage regulator may result.

5. Stop the engine by turning ignition switch to OFF position.
6. When mission is completed, wait at least 1 minute and place master battery switch in OFF position.

OPERATE PORTABLE FIRE EXTINGUISHER**WARNING**

Discharging large quantities of dry chemical fire extinguisher in cab may result in temporary breathing difficulty during and immediately after the discharge event. If at all possible, discharge fire extinguisher from outside the cab. Ventilate cab thoroughly prior to re-entry.

NOTE

This is a Monoammonium Phosphate (MAP) type B or C fire extinguisher. Use on oil and electrical fires only.

1. Remove fire extinguisher from bracket located to the right-rear of the operator's seat.
2. Hold fire extinguisher upright. Point nozzle toward base of fire and pull safety pin.
3. Squeeze lever, discharging chemical at base of fire. Use a side-to-side motion to spread the chemical.
4. After using fire extinguisher, notify Organizational Maintenance.

FORKLIFT KIT INSTALLATION

1. **General.**
 - a. The forklift kit attaches to the tophandler twistlocks and hydraulic system. The forklift is attached with the kit in a folded configuration.
 - b. The procedure requires two personnel: one person in the cab operating the joystick controls and one person installing/removing retaining pins, connecting the hydraulic quick-disconnect hoses and ground guiding the operator.
 - c. The controls for spreading the tophandler 20 to 40 ft (6.10 to 12.19 m) become the fork spreading controls.
2. **Installing Forklift Kit.**
 - a. Position tophandler directly over and level with forklift kit.
 - b. Lower tophandler onto forklift kit and secure with twistlocks.

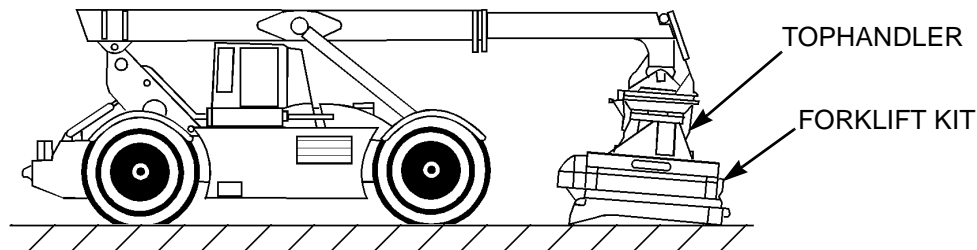

350-012

FORKLIFT KIT INSTALLATION - CONTINUED

- c. Release locking rings to disconnect two hydraulic hose quick-disconnects, located on top left side of the tophandler. Install protective caps on connectors.

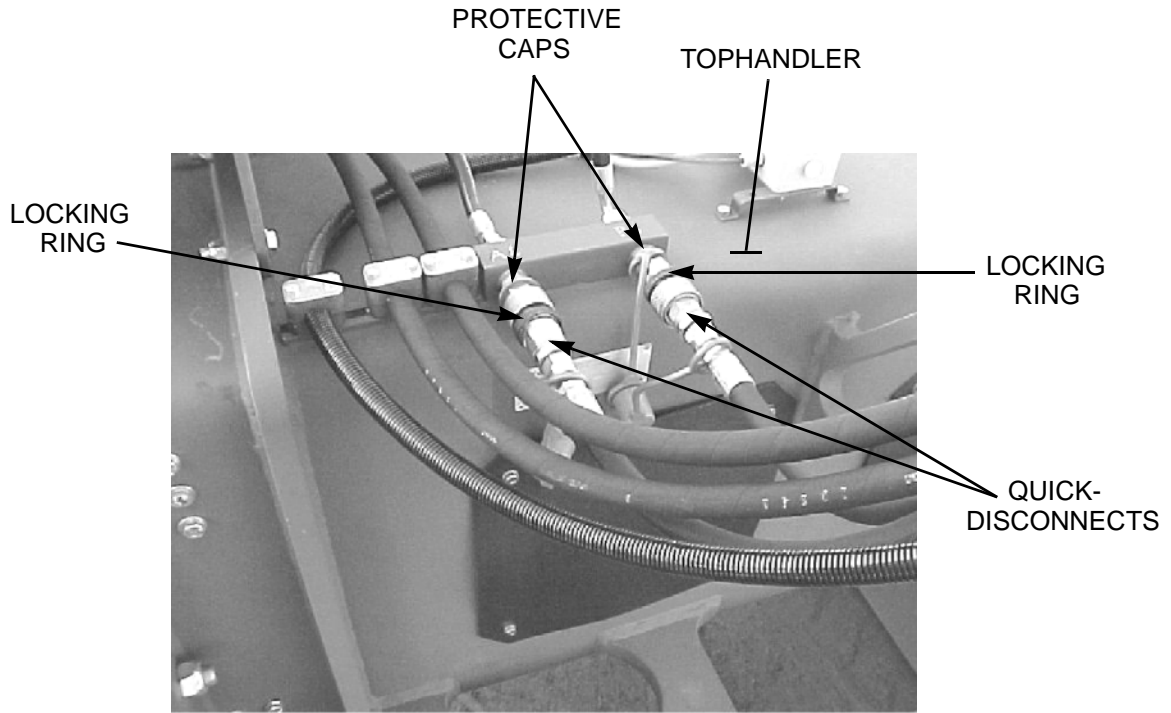

350-013

FORKLIFT KIT INSTALLATION - CONTINUED

- d. Remove protective caps from forklift kit hydraulic hose connectors. Connect the two forklift kit hydraulic hose quick-disconnects to the hydraulic hose quick-disconnects that were disconnected from the tophandler.

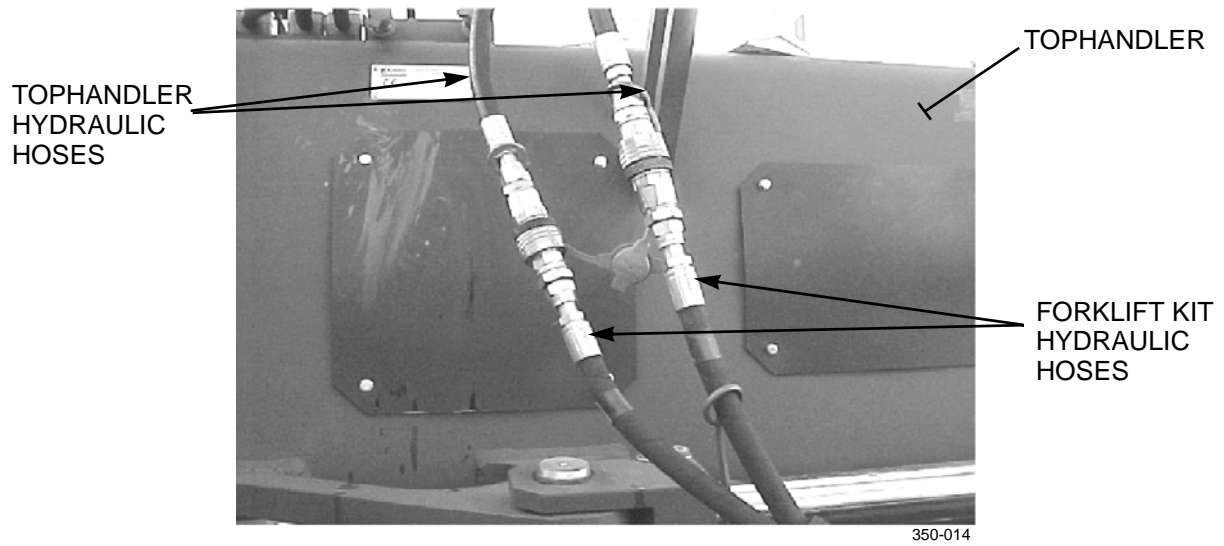

- e. Remove two locking pins and retaining pins that secure upper fork arms to the top frame.

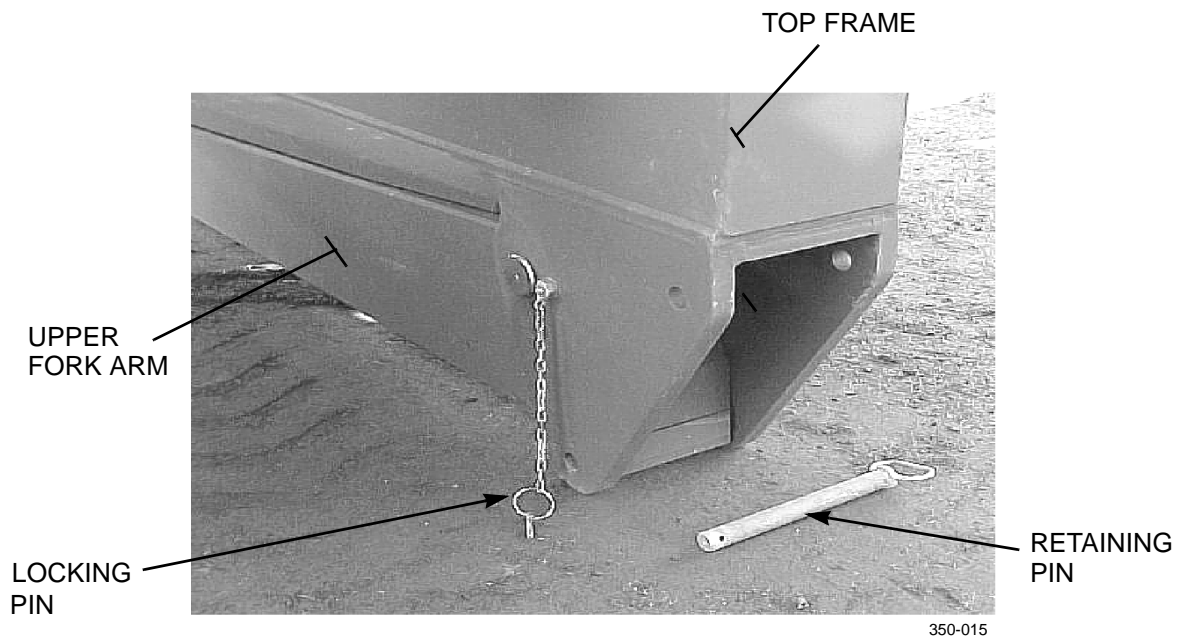

FORKLIFT KIT INSTALLATION - CONTINUED

- f. Stow retaining pins on forklift kit top frame.

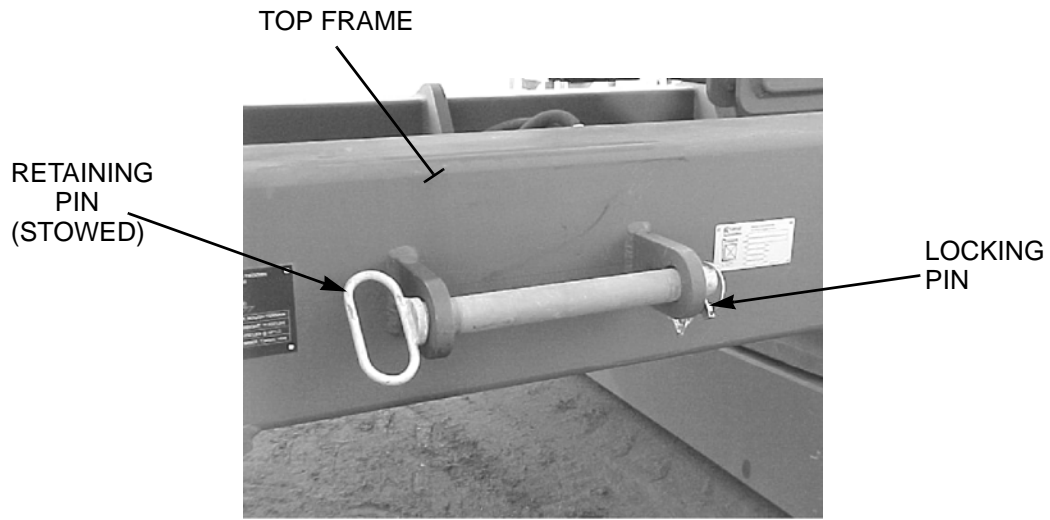

342-886

- g. Slowly tilt the tophandler/forklift kit to the full rearward position while raising the boom. This will allow the upper fork arms to unfold downward.

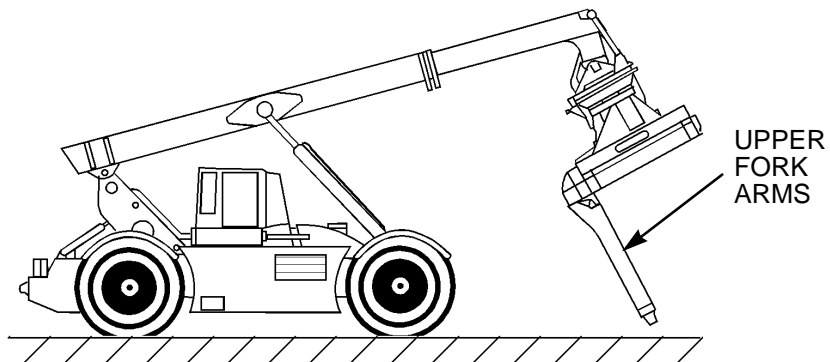

350-016

FORKLIFT KIT INSTALLATION - CONTINUED

NOTE

Step h requires a structure such as an ISO container or a loading dock to complete the unfolding of the lower forks.

- h. Retract the boom and position RTCH in front of an ISO container or loading dock.

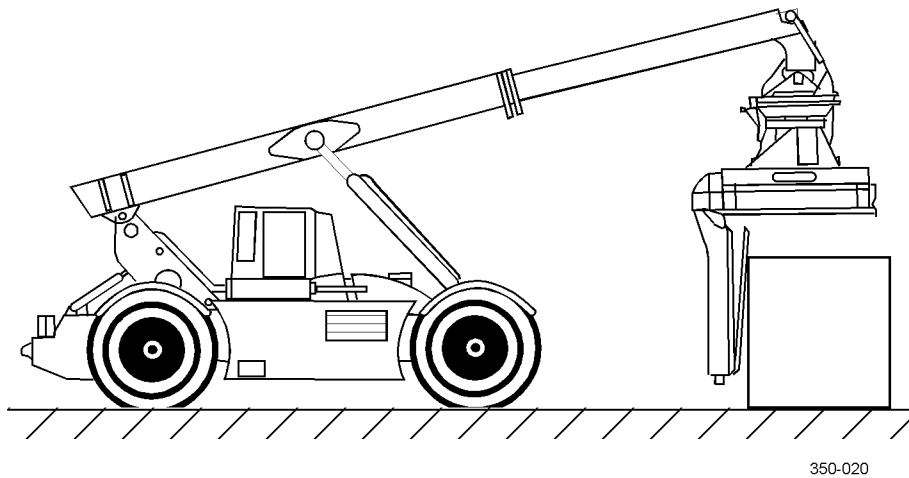

- i. Remove two locking pins and retaining pins that secure forks to upper fork arms.

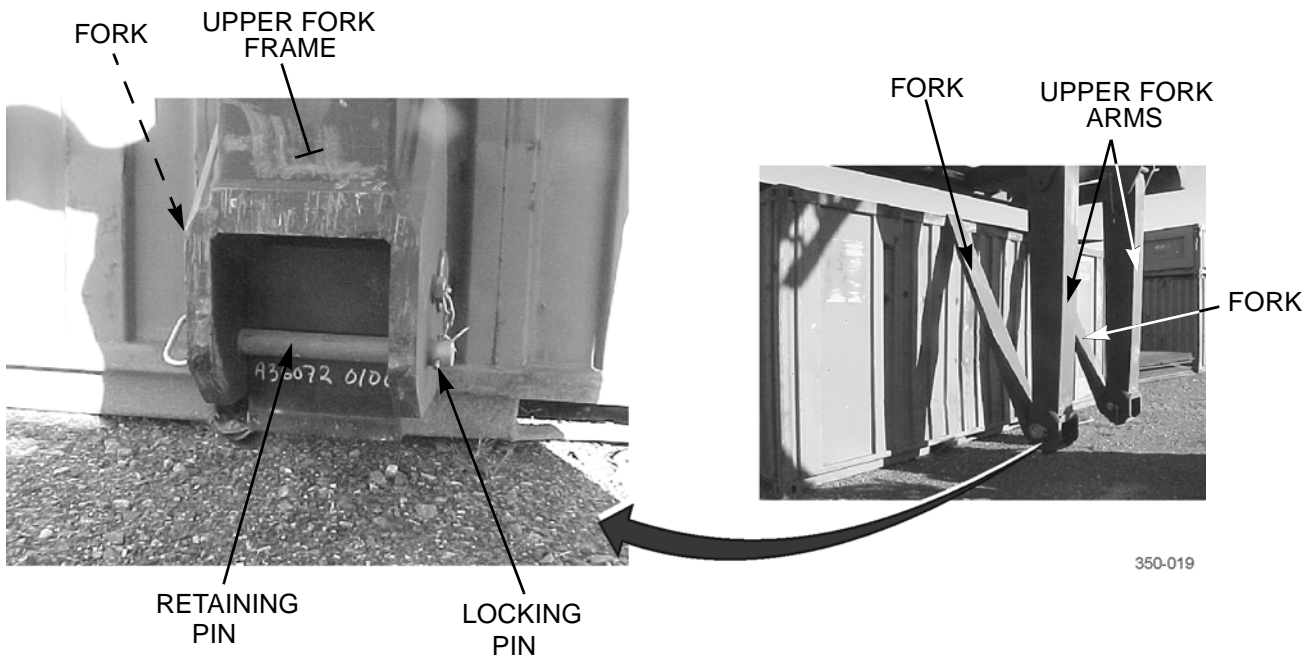

FORKLIFT KIT INSTALLATION - CONTINUED

- j. Raise the boom until the forks are even with sides of the container or vertical wall of the loading dock.
- k. Extend the boom until the forks are close to the vertical surface.

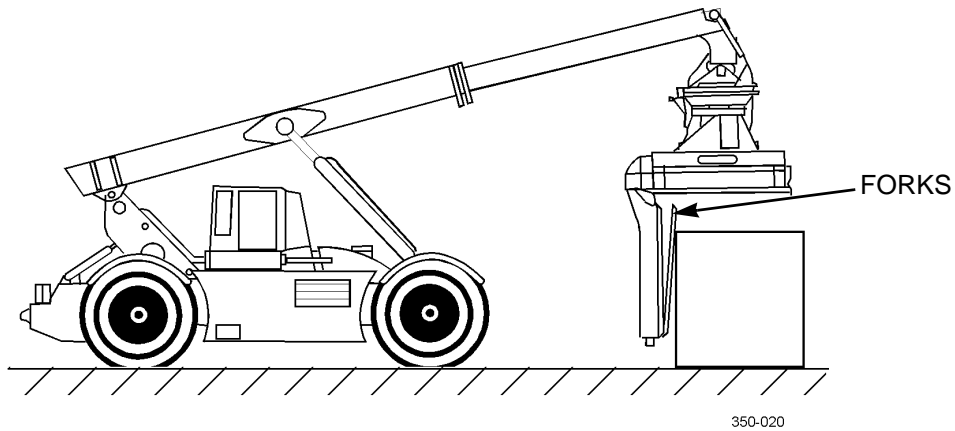

- l. Place transmission in Neutral (N).
- m. Slowly tilt the tophandler/forklift kit forward, then raise the boom. This will allow the RTCH to move rearward and the forks to fold out to the horizontal position.

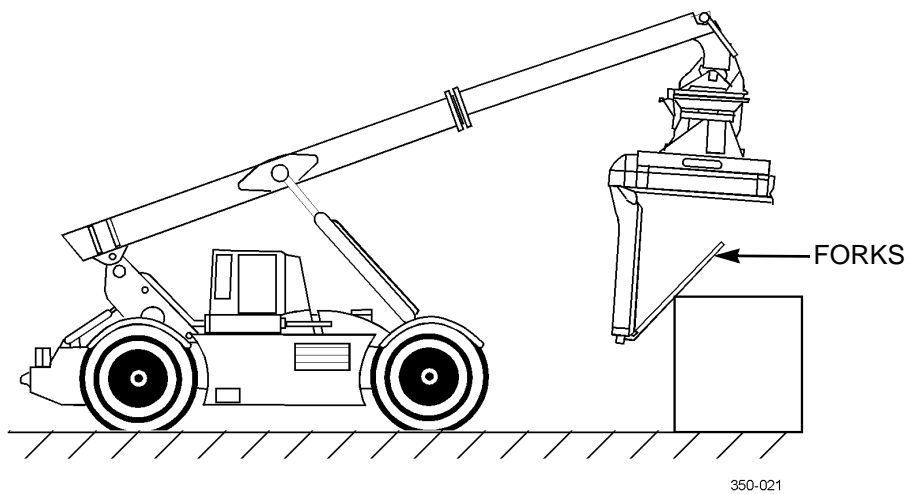

FORKLIFT KIT INSTALLATION - CONTINUED

- n. Retract the boom and level the forklift kit using the joystick tilt control.

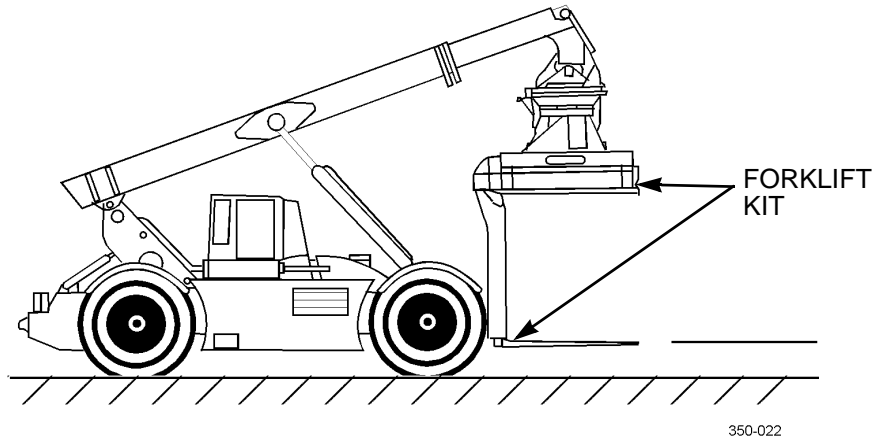

NOTE

Retaining pins should be installed from the outside.

- o. Install retaining pins and locking pins to secure forks to upper fork arms.

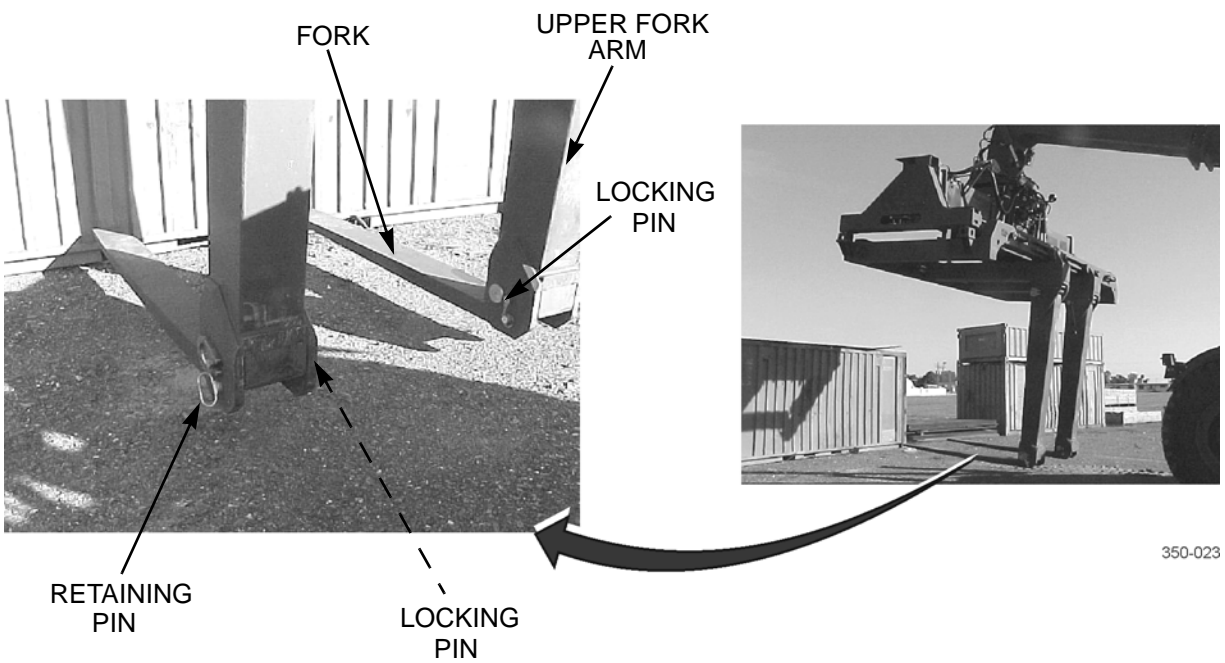

PARKING AND POSITIONING FOR SHORT- AND LONG-TERM STORAGE

The following instructions allow the RTCH-RT 240V2 to be parked or stored in a minimal amount of space and prevent damage to machine. The RTCH-RT 240V2 can be stored in four different modes.

1. Operational Mode with Tophandler Stowed in Normal Operating Position (Perpendicular to RTCH).

Lower boom to lowest position and fully retract boom.



374-0005M

2. Operational Mode with Tophandler Turned Longitudinal to RTCH.

a. Center tophandler by lining up white lines in middle.

b. Extend boom to 71 in. (180 cm) on extension screen and rotate tophandler clockwise to longitudinal position. Lower boom to lowest position and retract until tophandler is close to front tires.

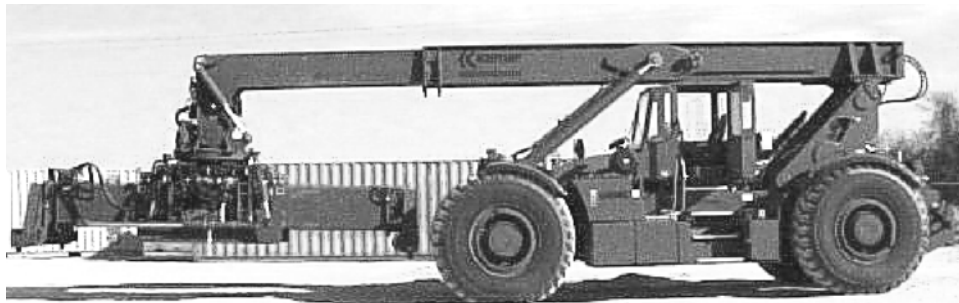

374-0006M

3. Cab and Boom in Transport Position with Tophandler Turned Perpendicular to RTCH.

a. Place cab in transport position (WP 0007 00).

b. Place boom support in transport position (WP 0007 00).

PARKING AND POSITIONING FOR SHORT- AND LONG-TERM STORAGE - CONTINUED

CAUTION

DO NOT place shoring next to twistlock pins where they will hit sensor plungers.

- c. Extend boom to 6 in. (15 cm) on extension screen and lower boom slowly to ground level. Place shoring under each corner of tophandler to prevent twistlocks from contacting ground.

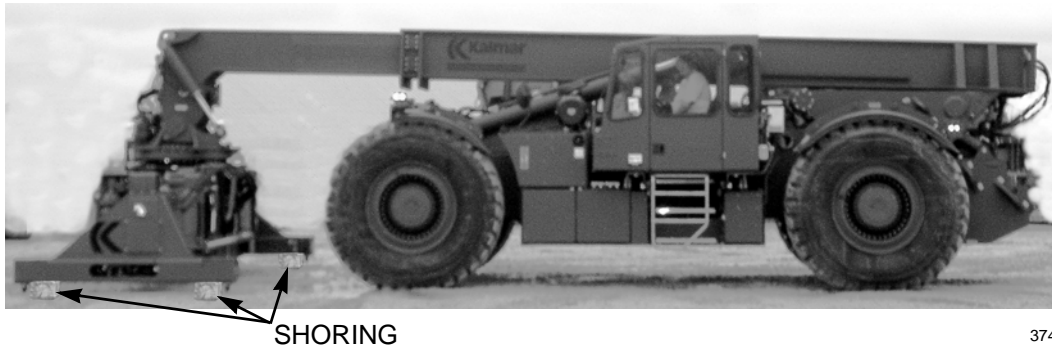

374-0008M

4. **Cab and Boom in Transport Position with Tophandler Turned Longitudinal to RTCH.**

- a. Place cab in transport position (WP 0007 00).
- b. Place boom support in transport position (WP 0007 00).

CAUTION

DO NOT place shoring next to twistlock pins where they will hit sensor plungers.

- c. Extend boom to 110 in. (279 cm) on extension screen. Rotate tophandler clockwise to the longitudinal position and lower boom slowly to ground level. Place shoring under each corner of tophandler to prevent twistlocks from contacting ground.

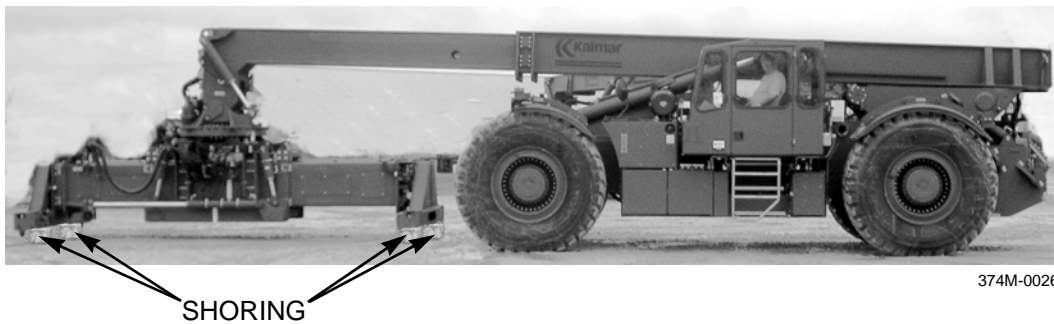

374M-0026

END OF WORK PACKAGE

OPERATION UNDER UNUSUAL CONDITIONS

0006 00

THIS WORK PACKAGE COVERS

General	Operate in Extreme Heat
Slave Starting	Operate in Mud or Soft Surfaces
Towing	Operate in Sandy or Dusty Conditions
Emergency Lowering of the Boom	Operate in Woods or on Rocky Terrain
Operate in Extreme Cold	Fording

INITIAL SETUP

Personnel Required

Two

References

FM 9-207
 WP WP 0005 00
 WP WP 0014 00

GENERAL

This section contains instructions for safely operating the RTCH-RT 240V2 under unusual conditions. In addition to normal preventive maintenance, special care must be taken to keep the RTCH operational in extreme temperatures and other environmental conditions.

SLAVE STARTING**WARNING**

- **When slave starting RTCH, use NATO slave cable that DOES NOT have loose or missing insulation.**
- **DO NOT proceed if suitable cable is not available.**
- **DO NOT use civilian-type jumper cables.**

The RTCH-RT 240V2 is equipped with a 24V, negative ground electrical system. The RTCH has two NATO slave receptacles. One receptacle is located on the left side of the RTCH within the battery box. The other receptacle is located on the right side of the RTCH to the rear of the right front tire.

NOTE

Ensure both RTCH and booster vehicle are equipped with serviceable NATO slave receptacles.

1. Connect slave cable to booster vehicle slave receptacle.

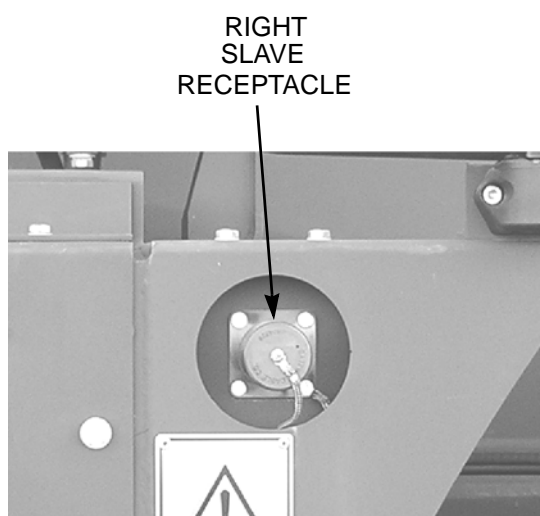
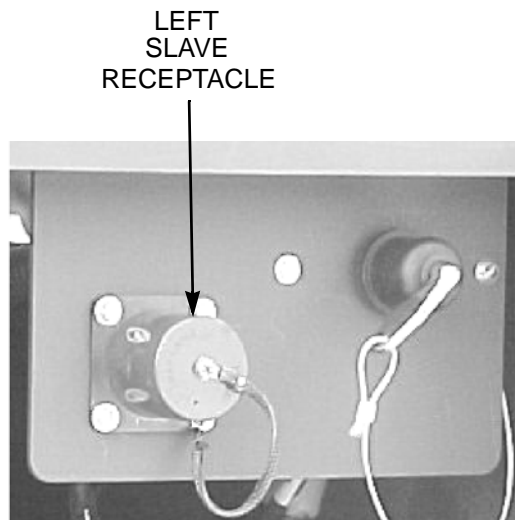
**RIGHT SIDE OF RTCH****LEFT SIDE OF RTCH**

374M-0027

SLAVE STARTING - CONTINUED

2. Connect other end of slave cable to slave receptacle on disabled vehicle.
3. Ensure disabled vehicle's master battery switch is in the ON position.
4. Start booster vehicle and run at a speed just above idle.
5. Wait approximately five minutes, then start disabled vehicle. If vehicle fails to start, notify Organizational Maintenance.
6. After starting disabled vehicle, return booster vehicle to idle.
7. Remove the slave cable from disabled vehicle, then from booster vehicle.

TOWING**WARNING**

DO NOT tow at speeds over 5 mph (8 kph).

CAUTION

DO NOT attempt to start the RTCH-RT 240V2 by towing. Any attempt to start the engine by towing will cause damage to the transmission.

NOTE

- **The preferred method for towing a disabled RTCH is with another RTCH, if one is available.**
- **The machine must ONLY be towed a short distance and at slow speeds. Distance towed and speed may not exceed 15 miles at 5 mph (25 km at 8 kph). If it is absolutely necessary to move the machine more than 15 miles (24 km), it must be transported.**
- **Because the engine is not running during towing, the following vehicle systems will NOT function properly.**
 - a. **Steering control will be greatly reduced.**
 - b. **Service brakes will not function.**
 - c. **Parking brakes will not release.**
 - d. **Transmission lubrication will be insufficient.**

1. Chock wheels of disabled RTCH.
2. Place transmission in neutral.
3. Apply parking brakes.
4. Turn ignition on.
5. Use auxiliary pump to power hydraulics to fully lower and retract boom. Turn tophandler to longitudinal position, so as not to obstruct traffic while being towed.
6. Turn ignition off.
7. Release parking brakes.
8. Have Organizational Maintenance cage parking brakes.
9. Connect a medium-duty tow bar with standard clevises to rear towing lugs of towing vehicle, another RTCH.

WARNING

Carefully move towing vehicle into position. Always use a ground guide and any device necessary to lift tow bar into position without standing directly between vehicles. Failure to follow this warning may result in equipment damage or injury or death to personnel.

10. Position towing vehicle directly behind the disabled RTCH. Connect tow bar to rear towing lugs of RTCH to be towed.

TOWING - CONTINUED**NOTE**

Master battery switch and ignition of towed RTCH must be ON to power computer and maintain correct wheel alignment during towing.

11. Turn on ignition and master battery switch of vehicle being towed. Place vehicle in 2-wheel steering mode (WP 0005 00).
12. Remove and secure wheel chocks. Ensure that all personnel and equipment are clear. Proceed to tow with caution.

EMERGENCY LOWERING OF THE BOOM**NOTE**

- Use the following procedures to lower the boom if the engine fails during RTCH operation.
- Boom movement during emergency lowering will be slow. This is normal.

1. **Lower Boom (Retracted and Unloaded).**
 - a. Loosen emergency lowering valve jamnuts on both left and right lift cylinder locking valves.
 - b. Turn both left and right emergency lowering valve screws counterclockwise three turns.
 - c. Turn left emergency lowering valve screw an additional three counterclockwise turns.
 - d. Turn right emergency lowering valve screw an additional three counterclockwise turns.
 - e. When boom is fully lowered, close both left and right emergency lowering valve screws by turning them clockwise until tight. Tighten both left and right jamnuts.

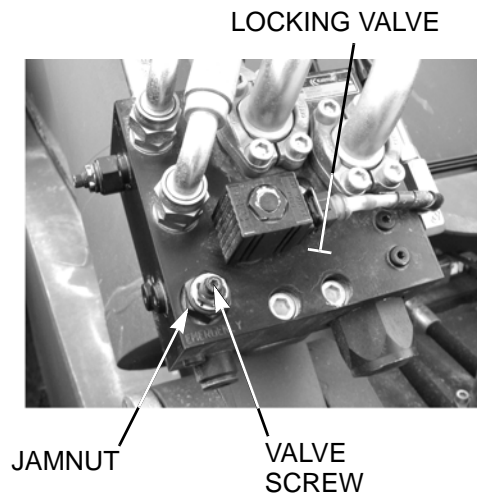
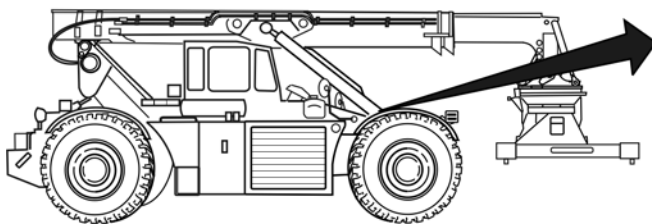

350-1368

EMERGENCY LOWERING OF THE BOOM - CONTINUED

2. **Lower Boom (Extended or Loaded with a Container).**
 - a. Open valve located under machine, on right frame, in front of right-rear tire.

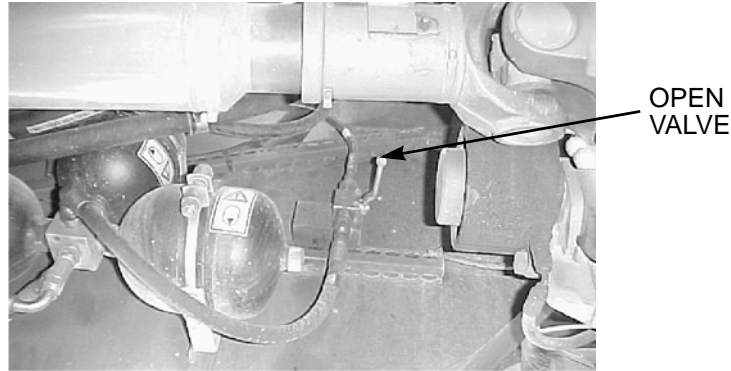

350-098

- b. Turn ignition ON.
- c. Press auxiliary pump switch on instrument panel to ON position. It will run for four minutes, pause for two minutes, and then restart, if necessary.
- d. Use joystick to lower and retract the boom.

OPERATE IN EXTREME COLD

1. **General.**
 - a. Extreme cold causes many problems:
 - (1) Lubricants thicken or congeal.
 - (2) Batteries may freeze or lose their electrical efficiency.
 - (3) Fuel may not readily atomize for combustion.
 - (4) Various materials will become hard, brittle, and easily damaged.
 - (5) The cooling system requires adequate protection from extreme cold.
 - (6) Fuels, lubricants, and antifreeze compounds require special storage, handling, and use.
 - b. Refer to FM 9-207 for additional information.

NOTE

Notify Organizational Maintenance to prepare vehicle for arctic operation.

- c. Vehicles assigned to arctic regions are equipped with an auxiliary arctic heater to enable easier starting by preheating engine cooling system.
- d. When starting out in extreme cold, follow these procedures:
 - (1) Be careful when you first start your vehicle. Use cold weather starting procedure (WP 0005 00-3) and allow engine time to reach operating temperature range of 180° to 200°F (82° to 93°C). Be alert that tires may be frozen to ground.
 - (2) Start driving very slowly for about 100 yd (91.4 m). If a problem is noted, notify Organizational Maintenance as required.

OPERATE IN EXTREME COLD - CONTINUED

e. When parking, follow these procedures:

- (1) If vehicle will be parked for a short period, park in a sheltered area out of wind. If shelter is not available, park vehicle so right side, where radiator is located, does not face into the wind.
- (2) If vehicle will be parked for a long shutdown period, try to park on high ground and use planks or brush to make a raised and relatively dry surface. Keep tires out of snow, water, ice, and mud, if possible.
- (3) Clean snow, ice, and mud from vehicle as soon as possible after shutdown.
- (4) If vehicle will be parked for a long period of time, have Organizational Maintenance remove and store batteries. Fill fuel tank to guard against condensation and drain any accumulated water from air reservoirs and fuel filters.
- (5) Ensure tires are properly inflated.

2. **Operate Arctic Heater (If Equipped).**

**WARNING**

DO NOT operate arctic heater in a confined area. Always ensure there is adequate fresh air ventilation. Failure to follow this warning may cause death due to carbon monoxide poisoning.

NOTE

- Arctic heater is used to provide engine preheating for engine startup in extreme cold, in temperatures below -25°F (-32°C). When heater is required to preheat engine coolant and engine block **BEFORE** startup, it should be turned on 3/4 hour before engine is started.
- Operating instructions for the arctic heater will be provided with the arctic heater installation kit.

OPERATE IN EXTREME HEAT

1. **General.** During very hot weather, driving procedures may require altering to prevent machine overheating. Avoid continuous high engine RPM and continuous operation in soft terrain.
2. **Driving Vehicle.**
 - a. Check water temperature display and stop if temperature is unusually high. Allow machine to cool down.
 - b. Check cooling system, air cleaner, air cleaner restriction indicator, engine oil level, and radiator fins frequently. Perform necessary services and notify Organizational Maintenance of any unusual readings or problems.
 - c. Notify Organizational Maintenance to shorten differential oil change interval.
3. **Parking Vehicle.**
 - a. Park vehicle under cover, if possible. If shelter is not available, cover machine with tarpaulins. If there are not enough tarps to cover entire vehicle, arrange tarps around engine compartment and over radiator to keep sand and dust out. Cover window glass to protect against sandblasting.
 - b. Ensure all tires are inflated to proper pressure.
 - c. Check frequently for rust. Clean and lubricate vehicle to help prevent deterioration.

OPERATE IN MUD OR SOFT SURFACES

1. Before driving in mud or other soft surfaces, select appropriate transmission gear range. Use 4-wheel drive as required. Enter soft area at a medium speed for gear range selected. Avoid oversteering, if possible, while driving in mud.

OPERATE IN MUD OR SOFT SURFACES - CONTINUED

2. Maintain steady pressure on accelerator pedal to keep vehicle rolling until solid ground is reached. Do not accelerate to point where wheels spin, if possible.
3. If vehicle gets stuck, shovel a clear path ahead of each tire and try to pull out slowly in a low gear. Boards, brush, or similar materials may be placed under tires to provide traction.
4. Maintain steady, even movement with transmission in lower gears. Use 4-wheel drive as required. Try to keep vehicle rolling without straining engine and powertrain. If vehicle gets stuck, notify Organizational Maintenance.
5. If these efforts fail and it becomes evident that vehicle will not free itself, notify Organizational Maintenance to arrange for another vehicle to tow out RTCH.
6. Clean and inspect propeller shafts for proper lubrication.

OPERATE IN SANDY OR DUSTY CONDITIONS

Whenever operating in sandy or dusty areas, you should:

- a. Notify Organizational Maintenance to service cab air filters more frequently. Service engine air cleaner when inlet restriction indicator, at air cleaner, shows 22 in. of vacuum (WP 0014 00).



374M-0012

INLET RESTRICTION
INDICATOR

- b. Make sure each tire has a valve cap.
- c. Check engine and transmission temperature and engine oil pressure frequently.
- d. If vehicle overheats, stop and find out why. Service or notify Organizational Maintenance, as necessary.
- e. Make sure engine oil filler tube and transmission fluid filler tube are cleaned before dipsticks are removed to check fluid levels. Clean accumulations of sand and dirt from around fluid filler locations before checking or adding fluids.
- f. Clean spouts of fuel containers and areas around filler caps on fuel tanks before adding fuel. Under extremely sandy or dusty conditions, filter fuel when filling tanks.
- g. Cover window glass to protect against sandblasting when not in use.
- h. Clean, inspect, and lubricate propeller shafts more frequently.

OPERATE IN WOODS OR ON ROCKY TERRAIN

Ensure vehicle can clear obstructions and avoid low hanging tree limbs, which might cause damage.

OPERATE ON SNOW AND ICE1. **Driving.**

- a. Accelerate slowly to avoid spinning the tires.
- b. Drive at slower speeds.
- c. Give signals sooner.
- d. Apply brakes sooner to give early warning of intention to stop. This will also help to avoid skidding.
- e. Maintain double the normal distance from the vehicle ahead.
- f. Keep windshields, windows, mirrors, and lights clean and free of snow and ice. Use defroster to help keep glass free of snow and ice.
- g. If a difficult stretch of road approaches, stop and inspect it carefully before driving on it. Select transmission gear range that best suits road condition. Use 4-wheel drive as required.

2. **Stopping.**

- a. Ease up on accelerator, leaving vehicle in gear.
- b. Apply service brakes lightly and evenly. DO NOT pump service brake pedal.
- c. Always avoid sudden braking.

3. **Parking.** If parking on icy, slushy, wet, or muddy surfaces, place boards, brush, or other materials that will provide traction underneath tires. This will guard against tires freezing to the ground or becoming pocketed in ice and will provide some traction when vehicle is started and moving again.

FORDING1. **General.**

- a. Maximum fording depth is 5 ft (1.5 m).
- b. Minimize the amount of turning, if possible.

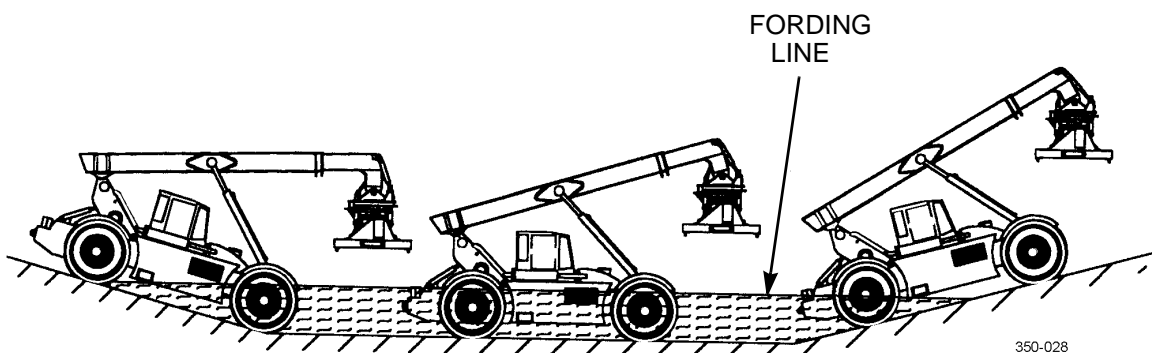

350-028

FORDING - CONTINUED

2. **Before Fording.**
 - a. Ensure engine is operating properly and all gages are indicating normal operating pressures and temperatures.
 - b. Lubricate unpainted surfaces to guard against rust and deterioration.
3. **During Fording.**
 - a. Place transmission in lower gear ranges and enter water slowly.
 - b. Ford at speeds of 3 to 4 mph (5 to 6 kph).
4. **After Fording.**
 - a. Allow engine to run for a while to drive out any accumulated water.
 - b. Drain and dry any area where water has accumulated.
 - c. Check all fluids for signs of contamination and for proper levels.
 - d. Lubricate all grease fittings below water line.
 - e. If vehicle has operated in salt water, rinse the entire vehicle with fresh water as soon as possible.
 - f. Notify Organizational Maintenance to remove drain plug from engine flywheel housing and check for signs of water.

END OF WORK PACKAGE

NOTE

In order to prepare the RTCH-RT 240V2 for transport, all procedures in this work package, except for *Self-Deployment*, require that the boom support be lowered. The boom support cannot be lowered unless the cab has first been placed in transport position (to the left and fully lowered).

SELF-DEPLOYMENT

WARNING

While operating a RTCH in self-deployment, 2-wheel steering mode, the maximum travel speed of 23 mph (37 kph) should never be exceeded. When on downhill grades, extra care should be exercised not to allow the RTCH to coast into an over speed condition, in excess of 23 mph (37 kph). Failure to keep maximum speed at or below 23 mph (37 kph) could result in major damage to the drive train components and loss of operator control. Under no circumstances should the parking brake be applied to attempt to rapidly reduce RTCH speed.

NOTE

- The RTCH may be deployed with forklift kit attached only when moving between remote areas, NOT on highways or streets. Forklift kit may only be deployed with tophandler oriented in normal operational position, NOT longitudinal position. With forklift kit attached, overall lowered height of vehicle is increased by 3 ft (0.9 m). This makes the lowered height (with clearance under forklift kit) approximately 16 ft 1 in. (4.9 m). This height is acceptable for movement between remote areas but not for highway and/or street movement, due to overhead wires and structures.
- Refer to data plate on forklift kit for rail or trailer transport instructions.
- Refer to WP 0002 00, WP 0004 00, and WP 0005 00 for the location and operation of RTCH controls, indicators, and components.

1. Fully lower boom to lowest position and tilt tophandler to a level parallel with the ground.
2. Extend boom 150 in. load center (load/weight screen).
3. Side shift the tophandler 6-8 in. to the right and place the float locks in locked position.
4. Rotate tophandler 90 degrees clockwise to longitudinal (in line with machine when seated in cab) position.

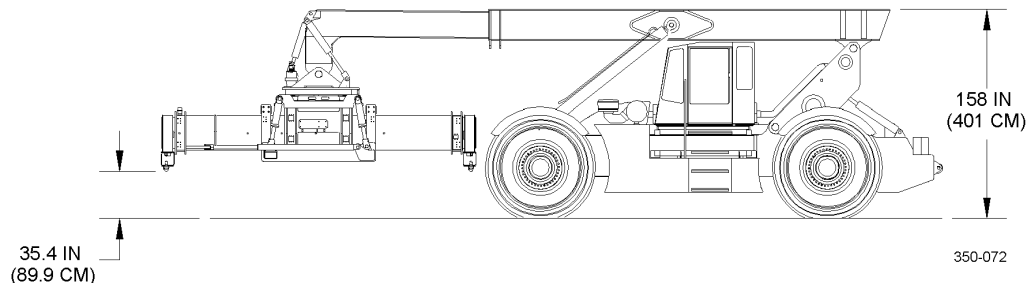

SELF-DEPLOYMENT - CONTINUED

5. Select 2-wheel steering mode (WP 0005 00).
6. Turn on lights and hazard warning lights, as required.

PLACING CAB IN TRANSPORT POSITION**NOTE**

Refer to WP 0002 00, WP 0004 00, and WP 0005 00 for the location and operation of RTCH controls, indicators, and components.

1. **Move Cab to Transport Position.**

WARNING

When moving cab into transport position, place hands on side of cab out of way of gears. Failure to do so may result in injury to personnel.

NOTE

If RTCH cab is being moved to transport position in order to perform maintenance, it may not be possible to run engine. Auxiliary pump will operate without engine running.

- a. Run RTCH engine at idle.

PLACING CAB IN TRANSPORT POSITION - CONTINUED

NOTE

Skip step b if RTCH cab is being moved to transport position in order to perform maintenance or if boom support is NOT going to be lowered.

- b. If boom support is to be lowered, remove retaining pin from boom support locking pin extension on each side of boom support.

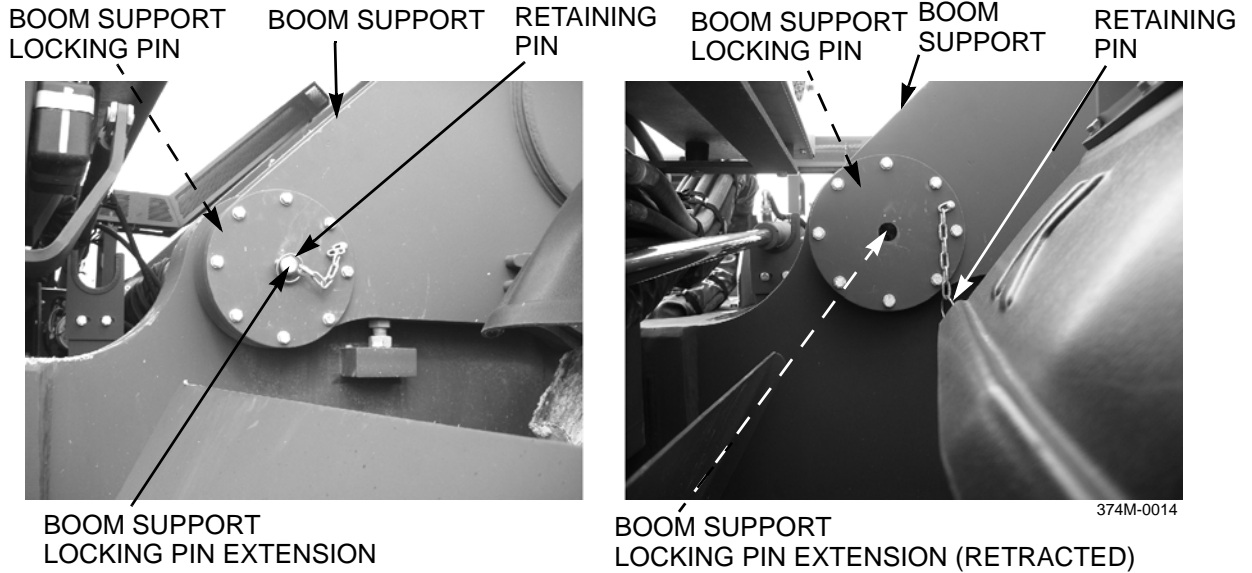

NOTE

It may be necessary to turn on the auxiliary pump and slowly move the cab to aid in releasing the cab pins.

- c. Release cab by removing two retaining pins and pins from cab subframe.

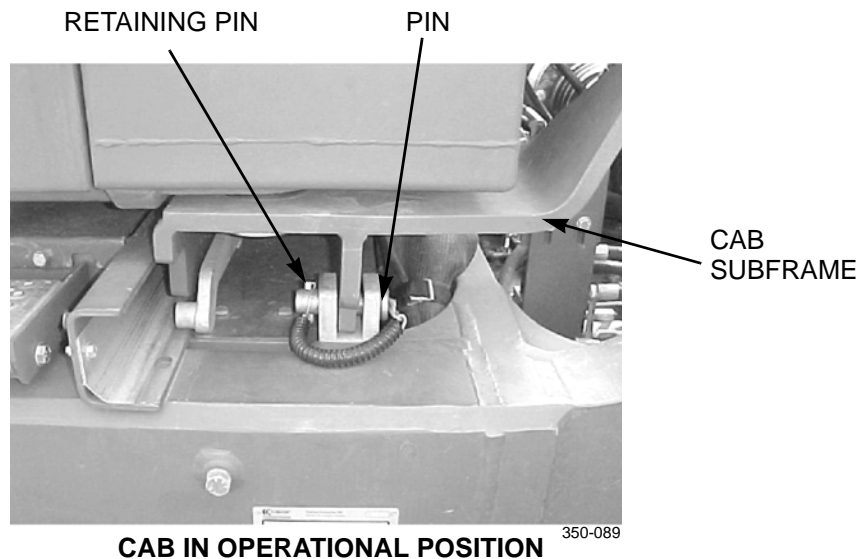

PLACING CAB IN TRANSPORT POSITION - CONTINUED

- d. Remove two retaining pins and remove handrail.

NOTE

The auxiliary pump runs for approximately four minutes. If the pump shuts off, it may be necessary to push auxiliary pump switch on instrument panel inside cab to restart auxiliary pump.

- e. Push auxiliary pump switch on instrument panel inside cab to start auxiliary pump.
- f. Open door of remote hydraulic control compartment.
- g. Pull cab lift/lower lever to raise cab transport lift until cab track is level with current cab position.

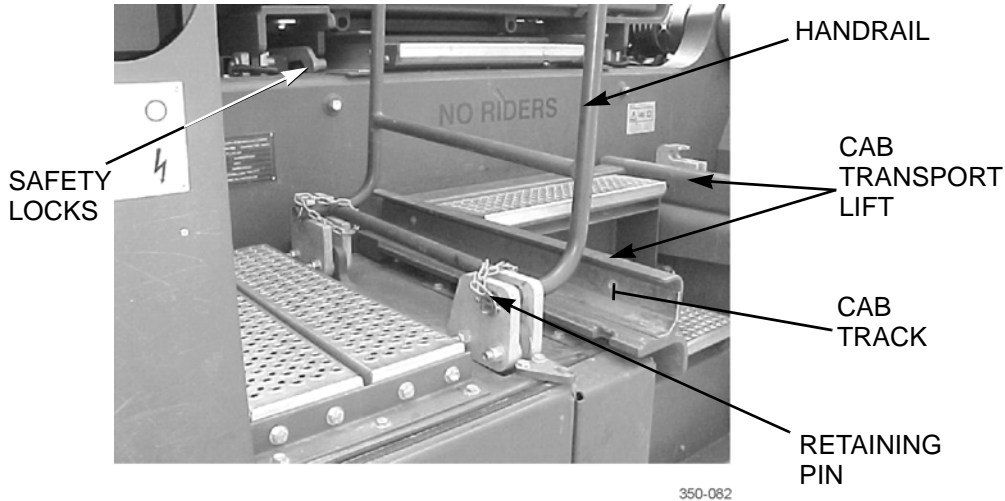

- h. Pull cab side movement lever until cab has moved all the way to the left and safety locks drop into place on cab track.
- i. Slowly push cab lift/lower lever and lower cab to transport height.
- j. Push cab side movement lever to gently move cab slightly to the right, so that cab securing pins can be installed. Close and latch door of remote hydraulic control compartment.

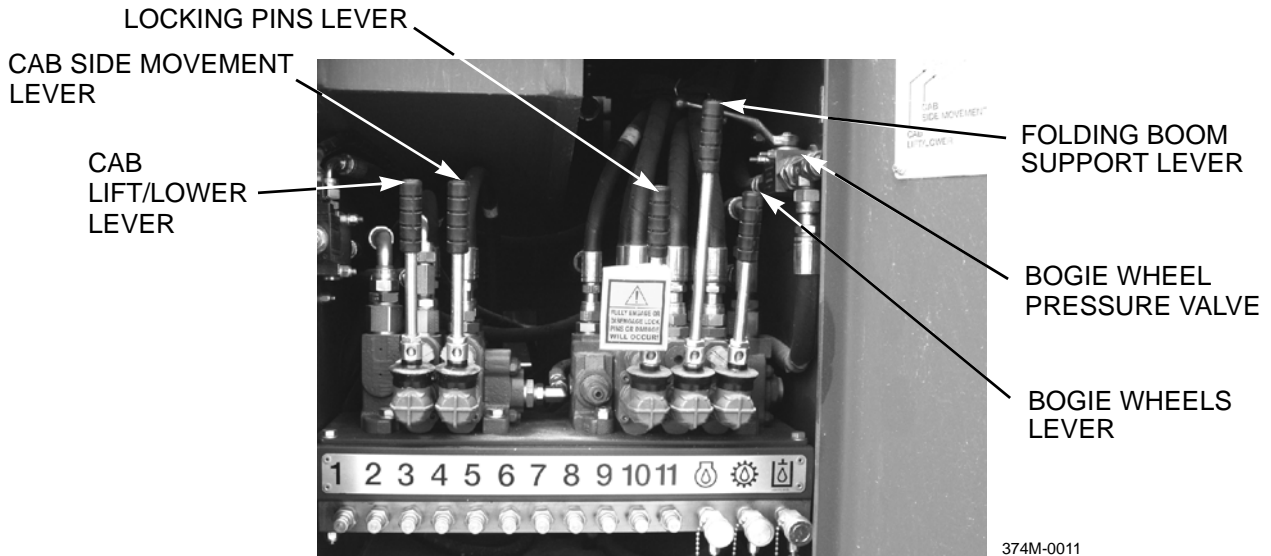

PLACING CAB IN TRANSPORT POSITION - CONTINUED

NOTE

Pins should be installed from the rear. Install rearmost pin first.

- k. Install two pins and retaining pins to secure cab in transport position.

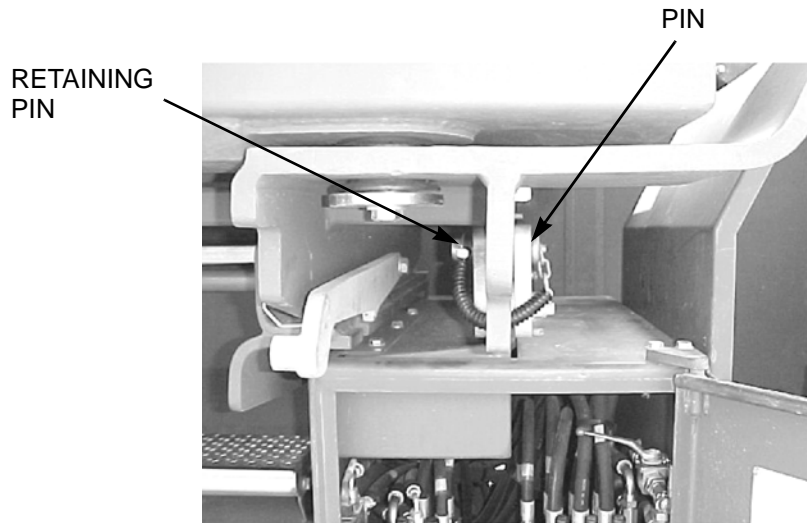

CAB IN TRANSPORT POSITION 350-083

- l. Reinstall handrail, now configured as a ladder, on cab in transport position. Secure with two retaining pins.
- m. Push auxiliary pump switch on instrument panel inside cab to turn pump OFF.
- n. To continue preparation for transport, refer to *Fold Boom Support* in this work package.

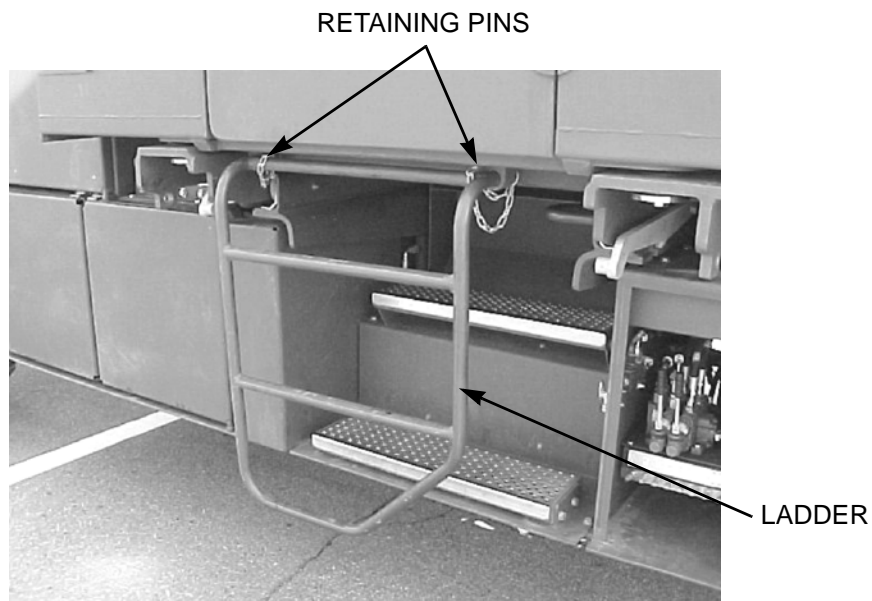

350-842

PLACING CAB IN TRANSPORT POSITION - CONTINUED

2. **Return Cab to Operational Position.**

- a. Run RTCH engine at idle.
- b. Push auxiliary pump switch on instrument panel inside cab to start auxiliary pump.
- c. Remove two retaining pins and ladder.
- d. Open door of remote hydraulic control compartment.
- e. Release cab by removing two retaining pins and pins from cab.
- f. Pull side movement lever to move cab free of frame lock.
- g. Pull cab lift/lower lever until cab is fully raised.
- h. Push cab side movement lever until cab has moved all the way to center position.
- i. Push cab lift/lower lever to lower cab transport lift.

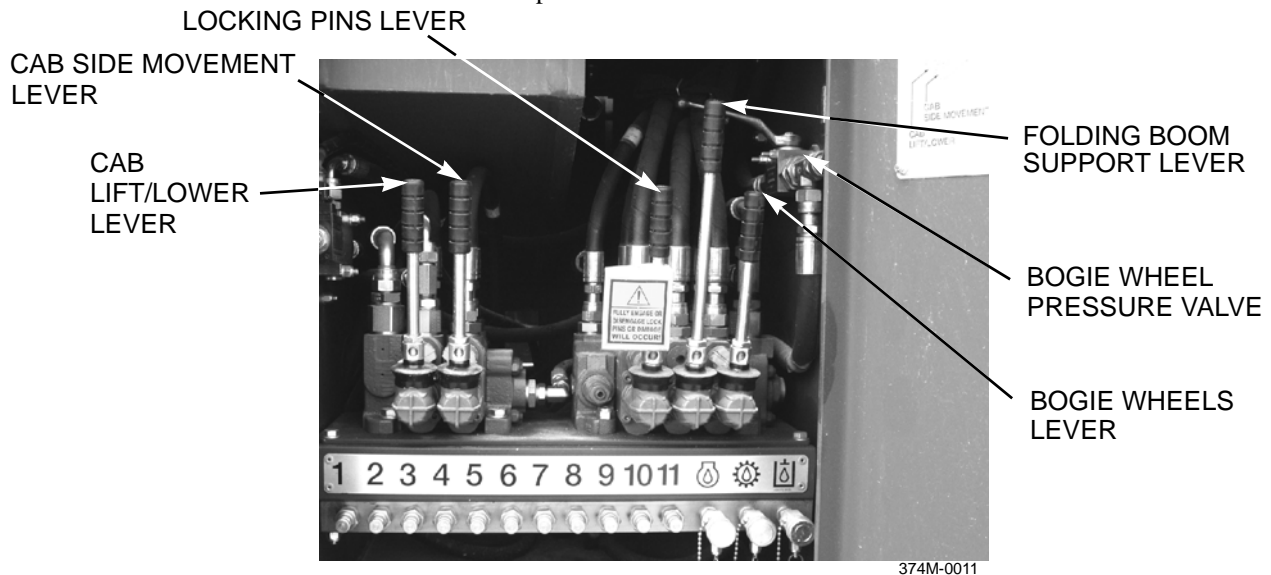

NOTE

- Cab side movement lever may need to be operated to move cab slightly side to side, to enable installation of pins.
 - Pins should be installed from the rear. Install rear pin first.
- j. Lock cab in operational position by installing two pins and retaining pins to cab subframe.
 - k. Close and latch door of remote hydraulic control compartment.
 - l. Push auxiliary pump switch on instrument panel inside cab to turn pump OFF.



WARNING

DO NOT stand between the tires and the fenders when installing retaining pins. Failure to follow this warning could result in injury or death.

- m. If removed, install retaining pins in left and right boom support locking pin extensions.
- n. Install handrail with two retaining pins.

PLACING BOOM SUPPORT IN TRANSPORT POSITION**NOTE**

Boom must be raised to 19 degrees (as shown on bottom of ECS display, Boom and Tophandler Lift Angle screen) and extended to 110 in. (279 cm) (as shown on ECS display, Boom Extension screen). To get to 19 degrees, tophandler will have to be left in normal operating position and turned to longitudinal position after locking pins are retracted and boom support is folded.

1. **Fold Boom Support.**

- a. If not previously removed, remove retaining pin from boom support locking pin extension on each side of boom support.

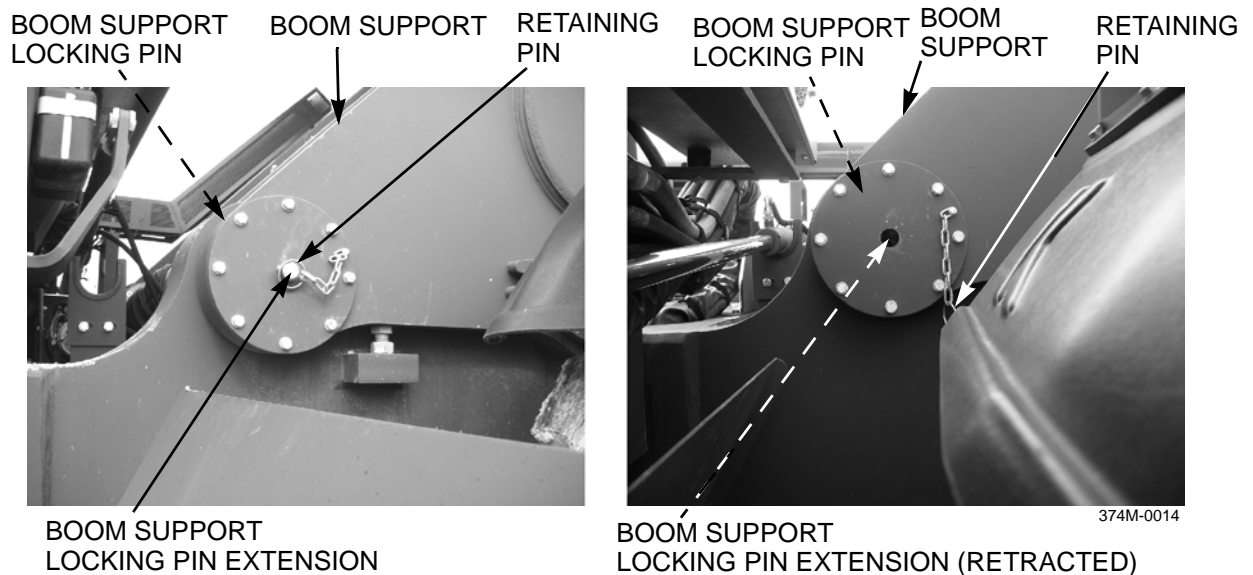

- b. Run RTCH engine at idle.
c. Open door of remote hydraulic control compartment.

CAUTION

DO NOT operate locking pin lever and folding boom support lever at the same time. If levers are operated at the same time, boom support locking pin extensions may shear.

NOTE

- If the hydraulic function for boom support locking pins, boom folding, or bogie wheel lowering are not working, it may be necessary to reposition cab closer to the frame.
- Pull folding boom suspension handle to ensure boom support is in fully raised position.
- Left and right boom support locking pins may not retract at the same time. Keep pushing locking pin lever until they both retract.

PLACING BOOM SUPPORT IN TRANSPORT POSITION - CONTINUED

d. Push locking pin lever to retract boom support locking pins.

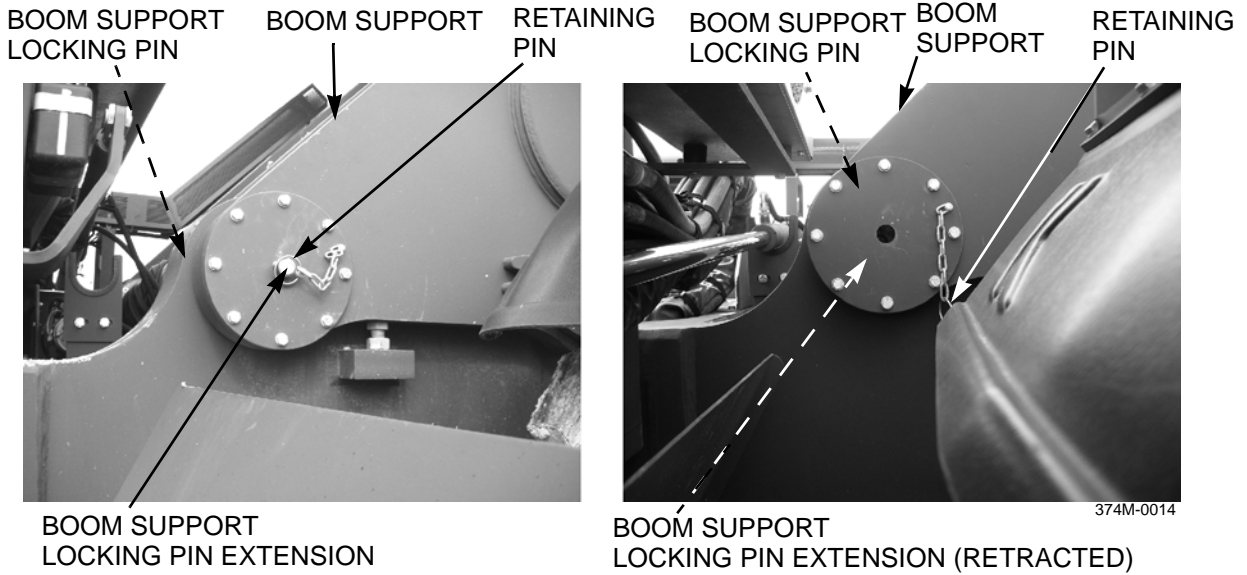

CAUTION

Ensure locking pins are fully retracted to avoid damaging them.

e. Visually inspect both sides to ensure left and right boom support locking pins have retracted.

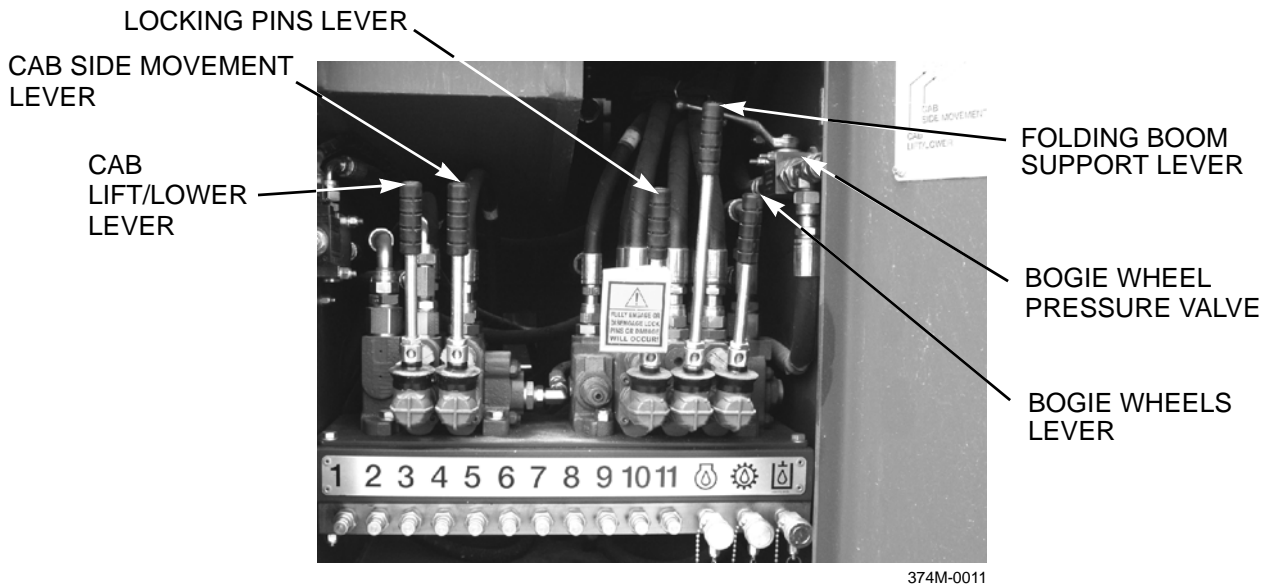

PLACING BOOM SUPPORT IN TRANSPORT POSITION - CONTINUED

- f. Push folding boom support lever to fold boom support SLOWLY until locking pins clear frame.
- (1) For highway or rail transport, lower boom support until it will not fold any more.
 - (2) For air transport, lower boom support to 30-degree mark on frame.

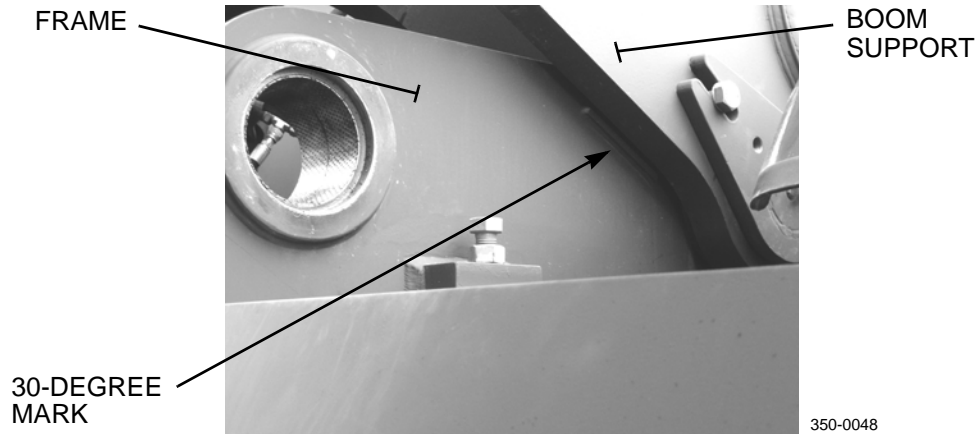

- g. Pull locking pin lever to extend boom support locking pins. Install retaining pins to secure in locked position.
 - h. Close and latch door of remote hydraulic control compartment.
2. **Raise Boom Support.**
- a. Run RTCH engine at idle.
 - b. Remove retaining pins from boom support locking pin extensions.
 - c. Open door of remote hydraulic control compartment.
 - d. If tophandler is longitudinal, place in operating position.
 - e. Raise boom about 12 to 13 ft (3.66 to 3.96 m) off the ground and extend to 110 in. (279 cm) on extension screen.
 - f. Push locking pins lever to retract boom support locking pins.
 - g. Pull folding boom support lever to raise boom support to upright position.

PLACING BOOM SUPPORT IN TRANSPORT POSITION - CONTINUED**CAUTION**

DO NOT operate locking pin lever and folding boom support lever at the same time. If levers are operated at the same time, boom support locking pin extensions may shear.

NOTE

Left and right boom support locking pins may not extend at the same time. Keep pulling locking pin lever until they both extend. Locking pins may also be difficult to extend. It may be necessary to raise the boom folding support to aid in releasing boom support locking pins.

- h. Ensure boom is raised to 19-degrees and extended to 110 in. (279 cm) degrees to extension.

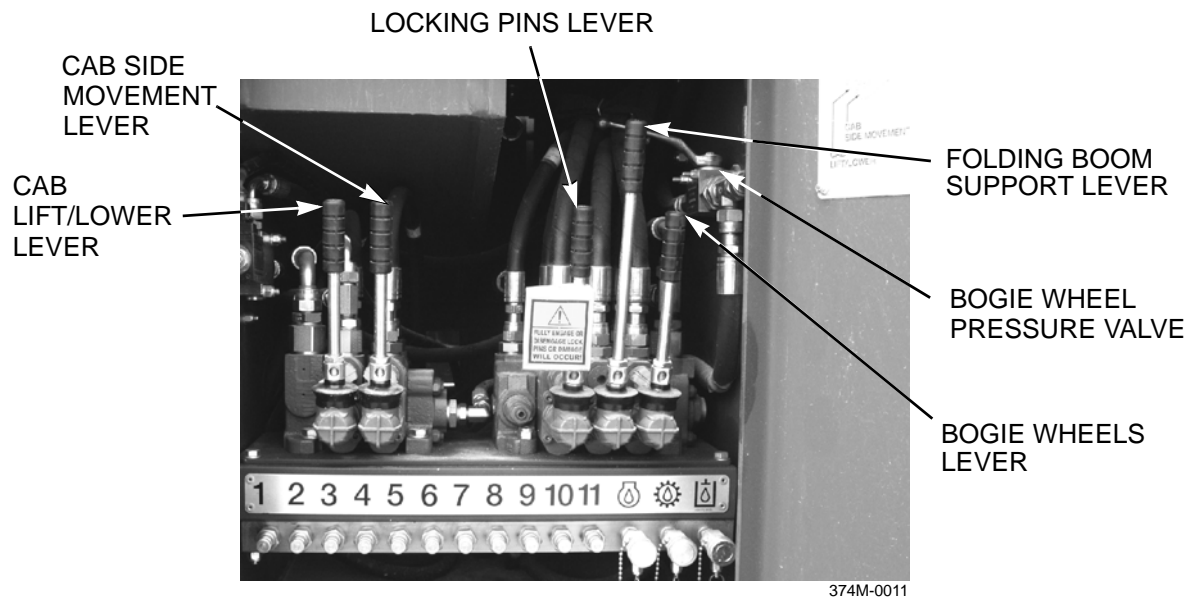

- i. Pull folding boom support lever to ensure boom support is fully raised.
 j. Pull locking pin lever to extend boom support locking pins.
 k. Install retaining pin in left and right boom support locking pin extensions.
 l. Close and latch door of remote hydraulic control compartment.

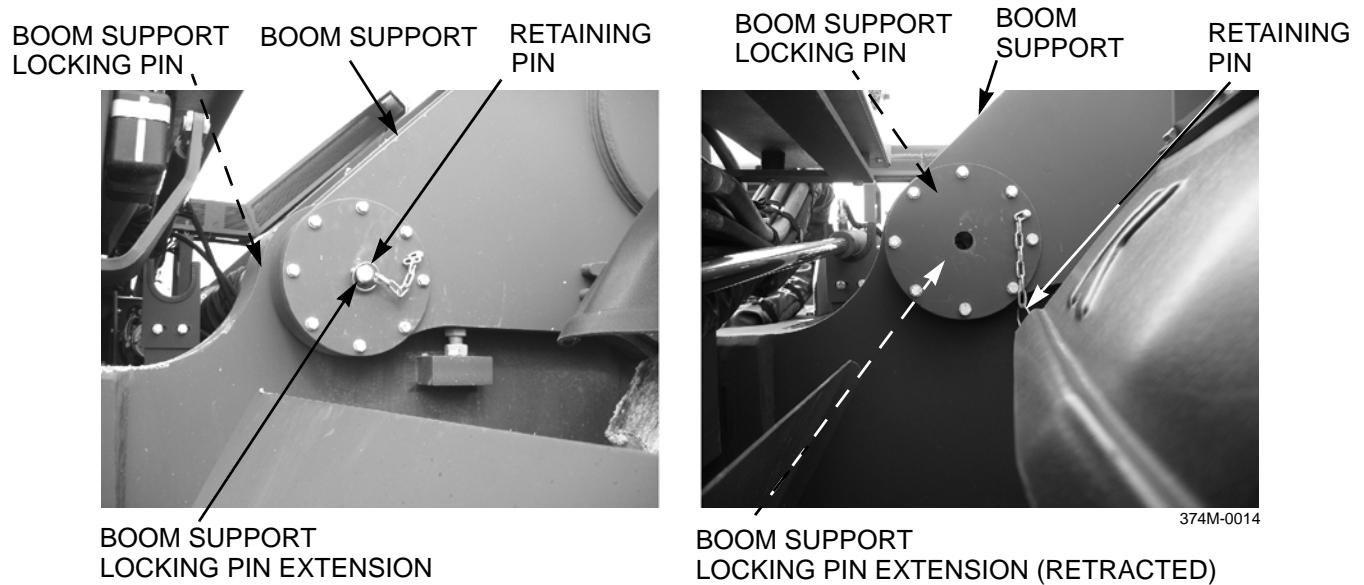
PLACING BOOM SUPPORT IN TRANSPORT POSITION - CONTINUED**HIGHWAY TRANSPORT****NOTE**

Refer to WP 0002 00, WP 0004 00, and WP 0005 00 for the location and operation of RTCH controls, indicators, and components.

1. **Load RTCH on M1000 Heavy Equipment Transport Trailer.**
 - a. Have Organizational Maintenance remove tophandler (TM 10-3930-675-24).
 - b. Lower loading ramps on M1000 trailer and place in outside (full wide) position (TM 9-2330-381-14).
 - c. Start RTCH engine and back vehicle up to and in line with trailer ramps.
 - d. Slowly back RTCH up loading ramps and onto M1000 trailer. Stop RTCH when directed to do so by ground guide.
 - e. Place cab in transport position (WP 0007 00).
 - f. Place boom and boom support in transport position (WP 0007 00).

WARNING

Always use a ground guide when backing RTCH up trailer ramps. Failure to use a ground guide may result in an accident, causing death or injury to personnel or damage to equipment.

CAUTION

With the tophandler removed, make sure the boom rest transport is properly installed and the boom fully lowered. Failure to do so will result in damage to equipment due to the boom drifting down and contacting the RTCH.

HIGHWAY TRANSPORT - CONTINUED

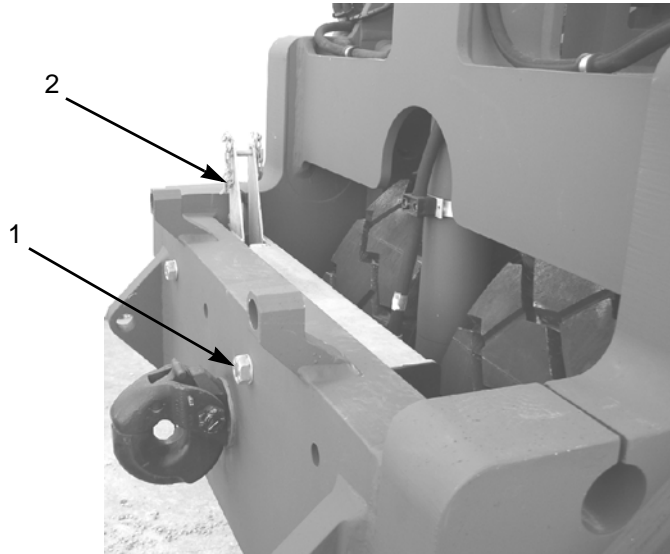

374M-0029

g. Remove two bolts (1) and transport boom rest (2) from inside rear bumper.

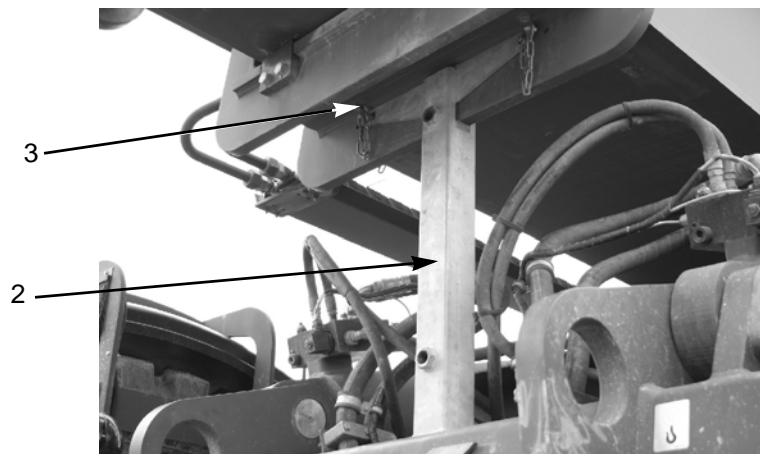

374M-0015

h. Install transport boom rest (2) on underside of boom at front and secure with two locking pins (3). Ensure boom is fully lowered and resting properly on transport boom rest.

i. Shut down RTCH engine.

j. Secure RTCH to trailer IAW tiedown instructions on RTCH data plate and on M1000 trailer.

k. Stow M1000 trailer loading ramps (TM 9-2330-381-14).

HIGHWAY TRANSPORT - CONTINUED

2. **Unload RTCH from M1000 Trailer.**
 - a. Remove tiedowns from RTCH and trailer.
 - b. Remove two locking pins (3) and transport boom rest (2) from underside of boom at front.
 - c. Install transport boom rest (2) and two bolts (1) on inside rear bumper.
 - d. Place boom and boom support in operational position (WP 0007 00).
 - e. Place cab in operational position (WP 0007 00).
 - f. Lower loading ramps on M1000 trailer and place in outside (full wide) position (TM 9-2330-381-14).
 - g. Start RTCH engine.

WARNING

Always use a ground guide when driving RTCH down trailer ramps. Failure to use a ground guide may result in an accident, causing death or injury to personnel or damage to equipment.

- h. Slowly drive RTCH down trailer ramps.
- i. Stow M1000 trailer loading ramps (TM 9-2330-381-14).
- j. Have Organizational Maintenance install tophandler (TM 10-3930-675-24).

RAIL TRANSPORT**NOTE**

Refer to WP 0002 00, WP 0004 00, and WP 0005 00 for the location and operation of RTCH controls, indicators, and components.

1. **Load RTCH on Rail Flatcar.**

- a. Drive RTCH, with tophandler attached, onto rail flatcar (MIL-STD-1366C).
- b. Place boom in operational position and raise to 19 degrees as shown on ECS display screen.
- c. Extend boom to 110 in. (279 cm) as shown on ECS display screen.
- d. Move cab to transport position. Refer to *Placing Cab in Transport Position* in this work package.
- e. Fold boom support to transport position. Refer to *Placing Boom Support in Transport Position* in this work package.
- f. Lower boom below 15 degrees and rotate tophandler 90 degrees clockwise to longitudinal position.
- g. Lower and retract boom until tophandler is located as close to machine front wheels as possible.
- h. Place four pieces of shoring (4 x 4, 6 x 6, etc.) under tophandler. **DO NOT** set under sensor plungers next to twistlock or place on tophandler transport support block.
- i. Lower tophandler onto shoring. Ensure tophandler leveling cylinders fully collapse when tophandler is lowered.
- j. Shut down RTCH engine.
- k. At side of locking valve at base of each lift cylinder, loosen float valve jamnut and turn float valve screw five turns counterclockwise. Retighten jamnut to prevent loss.

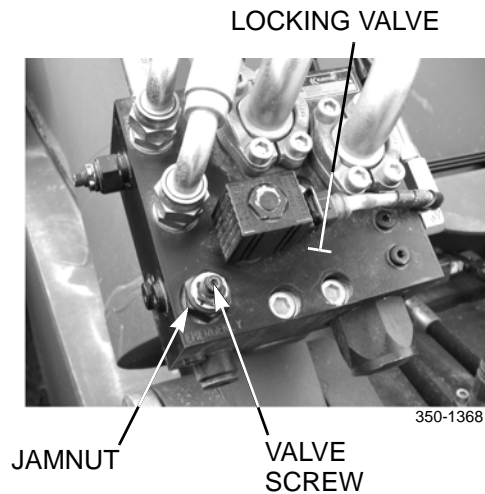
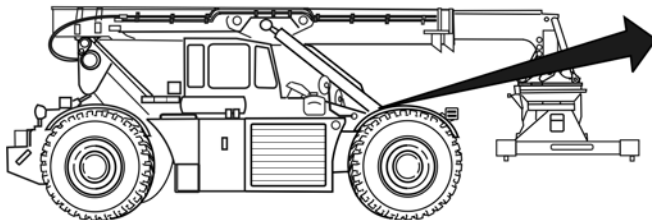

RAIL TRANSPORT - CONTINUED

1. Open both shutoff valves #6 slowly and at the same time.

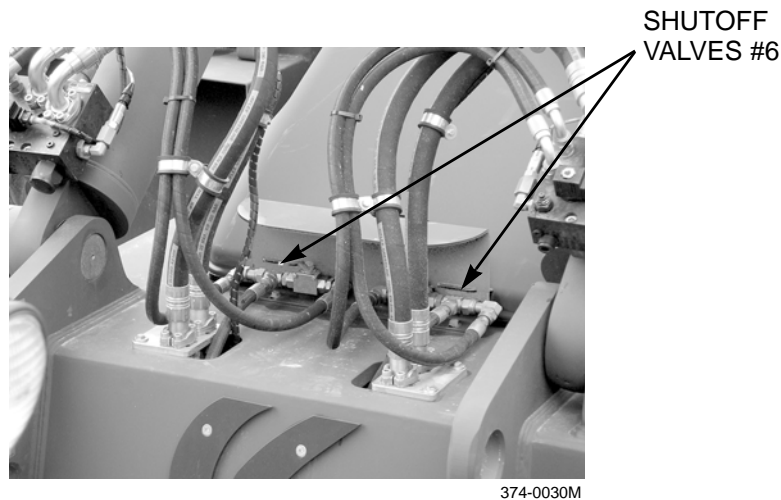

m. Secure RTCH to rail flatcar IAW tiedown instructions on RTCH data plate and on rail flatcar.

2. **Unload RTCH from Rail Flatcar.**

- a. Remove tiedowns from RTCH and rail flatcar.
- b. Close both shutoff valves #6.
- c. At side of locking valve at base of each lift cylinder, loosen float valve jamnut and turn float valve clockwise until tight. Retighten jamnut.
- d. Start RTCH engine.
- e. Raise tophandler slightly, remove shoring, and rotate 90 degrees counterclockwise in operational position.
- f. Raise and extend boom until extended to 110 in. (279 cm) and height is approximately 13 ft (3.96 m).
- g. Raise boom support. Refer to *Placing Boom Support in Transport Position* in this work package.
- h. Return cab to operational position. Refer to *Placing Cab in Transport Position* in this work package.
- i. Lower and retract boom.
- j. Rotate tophandler 90 degrees counterclockwise to place in operational position.
- k. Drive RTCH from rail flatcar (MIL-STD-1366C).

MARINE TRANSPORT

1. **Load RTCH on Ship.**

NOTE

- Refer to WP 0002 00, WP 0004 00, and WP 0005 00 for the location and operation of RTCH controls, indicators, and components.
 - Perform steps a through d if ship is equipped with roll-on/roll-off (RO/RO) capabilities.
- a. Start RTCH engine and rotate tophandler 90 degrees clockwise to longitudinal position.

MARINE TRANSPORT - CONTINUED

- b. Place boom in elevated position to clear door or bulkhead entry of ship.

WARNING

Always use a ground guide and DO NOT exceed 1 mph (1.6 kph) when driving RTCH up ramps in preparation for marine transport. Failure to use a ground guide may result in an accident, causing death or injury to personnel or damage to equipment.

- c. Back RTCH up ramp at door or bulkhead entry of ship. As machine approaches ship, lower boom to horizontal full-down position.
- d. Shut down RTCH engine.

NOTE

Perform steps e through h for MPS.

- e. Move cab and boom support to transport position. Refer to *Placing Cab in Transport Position* and *Placing Boom Support in Transport Position* in this work package.
- f. Lower boom below 15 degrees and rotate tophandler 90 degrees clockwise to longitudinal position.

WARNING

Always use a ground guide and DO NOT exceed 1 mph (1.6 kph) when driving RTCH up ramps in preparation for marine transport. Failure to use a ground guide may result in an accident, causing death or injury to personnel or damage to equipment.

- g. Back RTCH up ramp at door or bulkhead entry of ship. As vehicle approaches ship, lower boom to horizontal full-down position.
 - h. Shut down RTCH engine.
2. **Unload RTCH from Ship.**

NOTE

Perform steps a through e for MPS.

- a. Start RTCH engine.

WARNING

Always use a ground guide and DO NOT exceed 1 mph (1.6 kph) when driving RTCH down ramps after marine transport. Failure to use a ground guide may result in an accident, causing death or injury to personnel or damage to equipment.

- b. Drive RTCH out vehicle ramp at door or bulkhead entry of ship.
- c. Rotate tophandler 90 degrees counterclockwise to operational position.
- d. Shut down RTCH engine.
- e. Return boom support and cab to operational position. Refer to *Placing Cab in Transport Position* and *Placing Boom Support in Transport Position* in this work package.

MARINE TRANSPORT - CONTINUED**NOTE**

Perform steps f through h for ships equipped with RO/RO capabilities.

- f. Start RTCH engine.

WARNING

Always use a ground guide and DO NOT exceed 1 mph (1.6 kph) when driving RTCH down ramps after marine transport. Failure to use a ground guide may result in an accident, causing death or injury to personnel or damage to equipment.

- g. Drive RTCH out vehicle ramp at door or bulkhead entry of ship.
h. Shut down RTCH engine.

AIR TRANSPORT**NOTE**

- Refer to WP 0002 00, WP 0004 00, and WP 0005 00 for the location and operation of RTCH controls, indicators, and components.
- Fuel tank must be drained to ¼ tank or less.
- Perform the proper *PMCS* procedures (WP 0012 00 and WP 0013 00), paying close attention to all tire inflations and proper operation of the bogie screw and retaining collar.

1. **Load RTCH on C-5 or C-17 Aircraft.**

- a. Start RTCH engine, select 2-wheel steering, and ensure twistlocks are lined up.

WARNING

Always use a ground guide and DO NOT exceed 1 mph (1.6 kph) when driving RTCH up ramps in preparation for air transport. Failure to use a ground guide may result in an accident, causing death or injury to personnel or damage to equipment.

NOTE

- 2-wheel steering is required for aircraft loading and cannot be selected after RTCH is converted to transport position. If twistlocks are not lined up, they cannot be operated after RTCH is converted to transport position and tophandler and boom functions will be disabled.
 - Ensure RTCH is properly aligned with aircraft. After dolly wheels are installed on tophandler, RTCH is difficult to steer.
- b. Position RTCH in line with and facing aircraft loading ramp, as close as possible to aircraft.
c. Move cab to transport position. Refer to *Placing Cab in Transport Position* in this work package.
d. Raise boom to 19 degrees and extend boom to 110 in. (279 cm) as shown on ECS display screen.
e. Fold boom support. Refer to *Placing Boom Support in Transport Position* in this work package.
f. Lower to 30-degree mark on frame, extend boom to 160 in. (406 cm), and lower tophandler until it is approximately 18 in. (46 cm) off the ground.

WARNING

Tophandler must be aligned with RTCH to prevent damage while driving up ramp onto aircraft.

- g. Rotate tophandler clockwise to longitudinal position and ensure tophandler is aligned with RTCH.

AIR TRANSPORT - CONTINUED

WARNING

Ensure tabs on ramp are engaged into ramp seat holes in dolly wheel storage compartment. Failure to secure ramp properly may cause ramp to fall under weight of dolly wheel, causing injury to personnel.

- h. Open dolly wheel storage compartment. Unfasten straps and remove ramp from stowage. Position ramp against storage compartment.
- i. Remove dolly wheels from storage compartment. Check tire pressure to ensure all are at 85 psi (586 kPa).

DOLLY WHEELS STORAGE COMPARTMENT RAMP (STOWED)

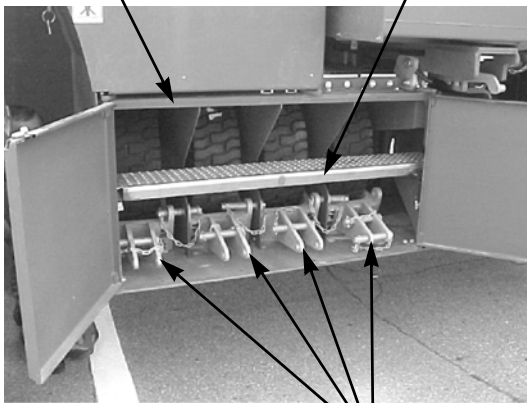

DOLLY WHEELS

RAMP

350-092

NOTE

When installed, front and rear dolly wheels are turned toward each other.

- j. Install each dolly wheel on tophandler:
 - (1) Place dolly wheel so that tire will be under the twistlock when wheel is lifted by tophandler.
 - (2) Install upper pin from outside of tophandler. Lock pin in position with retaining pin.
 - (3) Remove lower pin from dolly wheel and set aside.

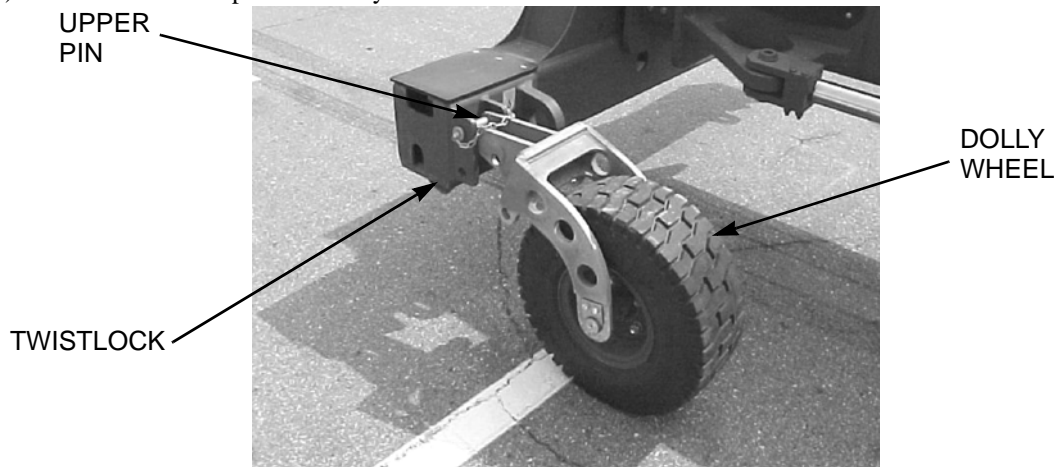

350-063

AIR TRANSPORT - CONTINUED

- k. Stow ramp in dolly wheel storage compartment. Secure ramp with straps.
- l. Raise tophandler so that dolly wheels are off the ground approximately 2 ft (61 cm).
- m. Install lower pin from outside toward center of tophandler in lower hole of each dolly wheel. Lock pin in position with retaining pin.

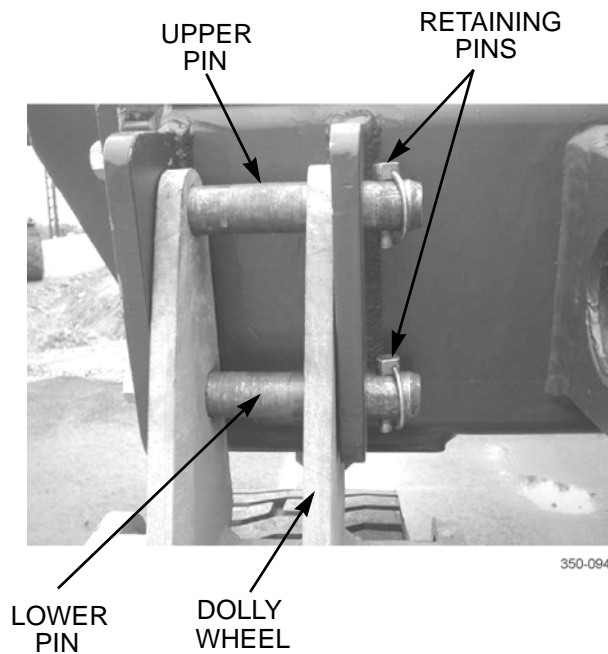

- n. Lower tophandler until all four dolly wheels are resting on ground.
- o. At side of locking valve at base of each lift cylinder, loosen float valve jamnut and turn float valve screw five turns counterclockwise. Retighten jamnut to prevent loss.

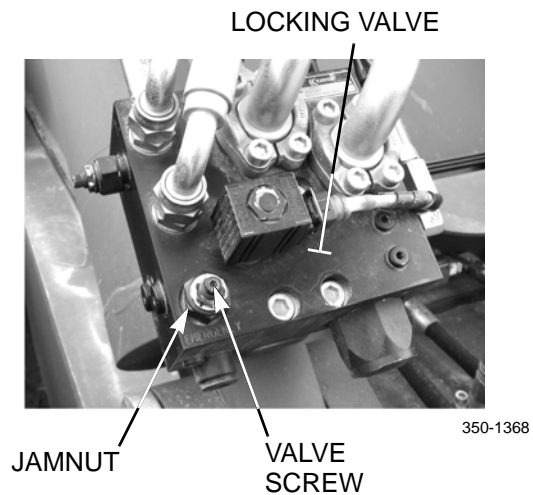
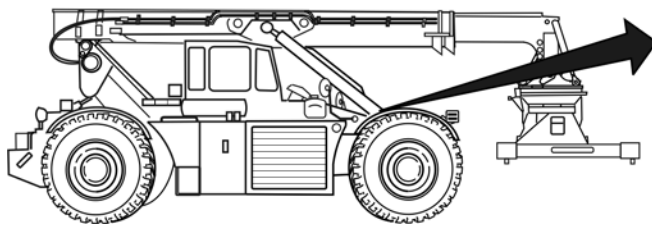

AIR TRANSPORT - CONTINUED

- p. At front of vehicle, open both shutoff valves #6 slowly and at the same time. Tophandler should now be resting on dolly wheels, in floating position.

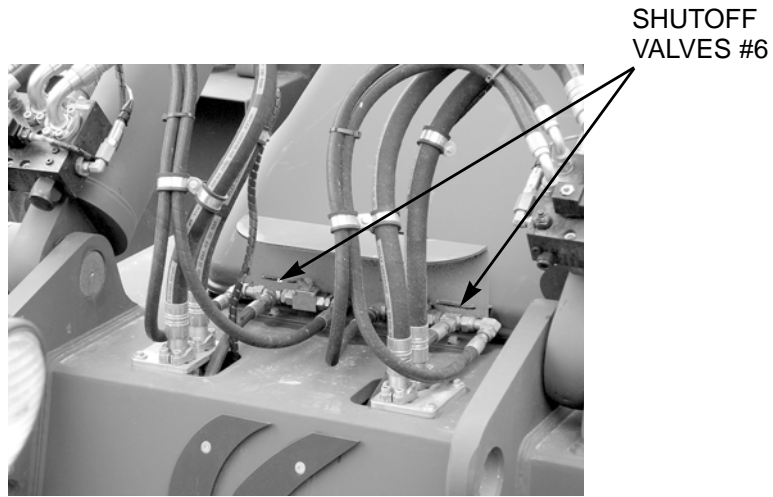

374-0030M

- q. Open remote hydraulic control compartment.

NOTE

With engine running, raise bogie wheels only enough to allow bogie wheel retaining collar to be unlocked. If wheel does not raise, check to make sure cab is positioned close to frame.

- r. Slowly pull bogie wheel lever to raise bogie wheels.

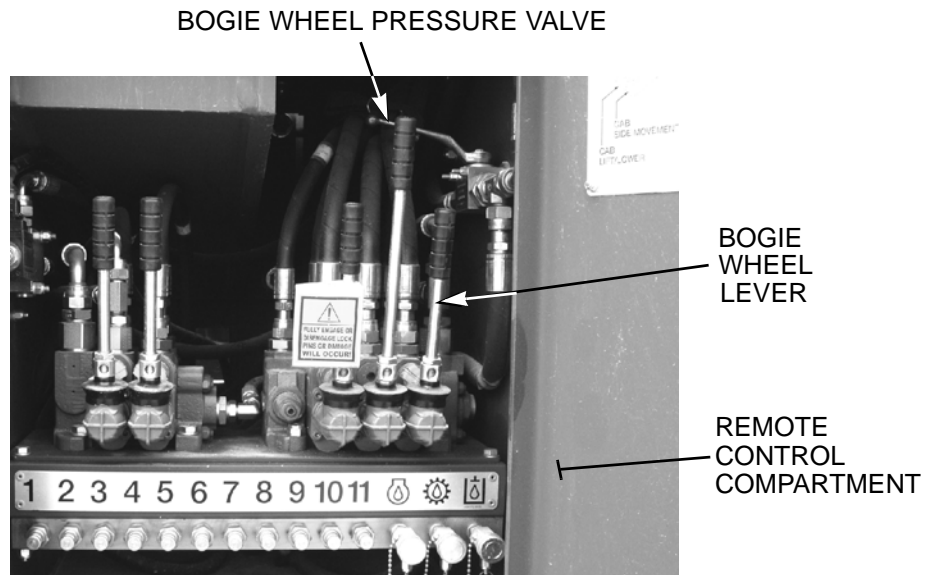

374M-0011

AIR TRANSPORT - CONTINUED

- s. Turn bogie wheel retaining collar $\frac{1}{4}$ turn clockwise to unlock bogie wheels. If retaining collar is still tight, use handle stowed in front of bogie wheels to rotate shaft.

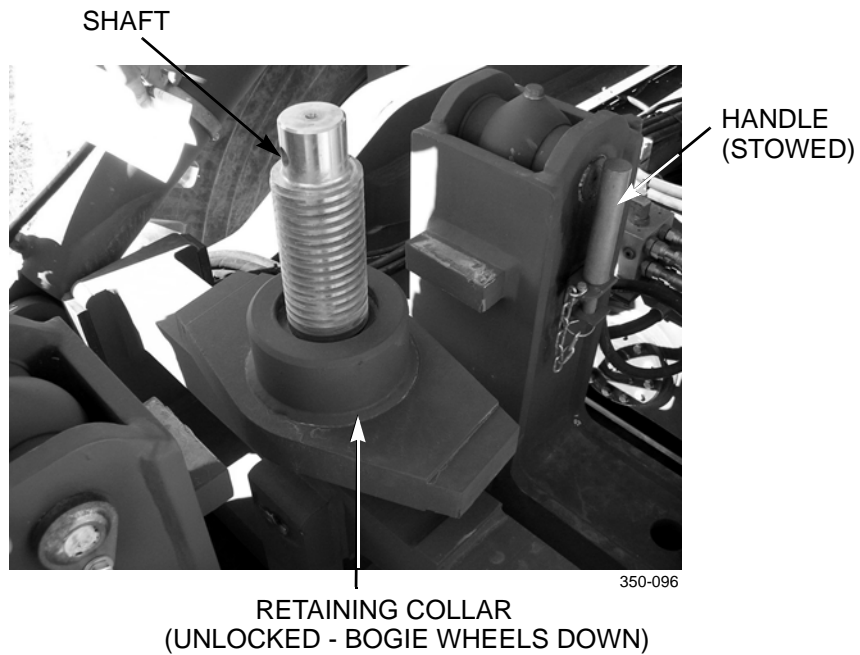

AIR TRANSPORT - CONTINUED

- t. Push bogie wheel lever to lower bogie wheels. Ensure wheels are lowered sufficiently to apply ground pressure.
- u. Open bogie wheel pressure valve inside remote hydraulic control compartment by turning handle 90 degree counter-clockwise. Bogie wheels will lower further and apply correct amount of ground pressure.

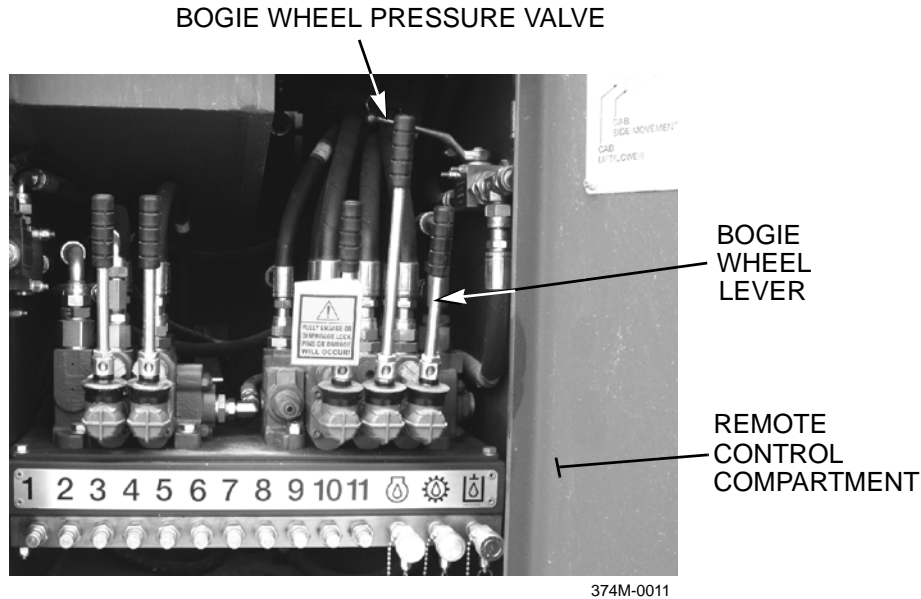
**WARNING**

Always use a ground guide (load master) and DO NOT exceed 1 mph (1.6 kph) speed when driving RTCH up ramps in preparation for air transport. Failure to use a ground guide may result in an accident, causing death or injury to personnel or damage to equipment.

CAUTION

Oversteering will damage dolly and bogie wheels.

- v. Use first gear and 2-wheel steering mode to slowly drive RTCH forward up ramps and position inside aircraft. DO NOT exceed 1 mph (1.6 kph) speed. Only slight steering corrections (no more than ¼ turn of steering wheel) are allowed during loading.
- w. Lower boom support to the maximum onto the frames. Refer to *Placing Boom Support in Transport Position* in this work package.

AIR TRANSPORT - CONTINUED

- x. Rotate bogie wheel retaining collar $\frac{1}{4}$ turn clockwise to lock bogie wheels in position. It may be necessary to screw shaft down to take up slack in bogie wheel lock, using handle stowed on bogie wheel frame.

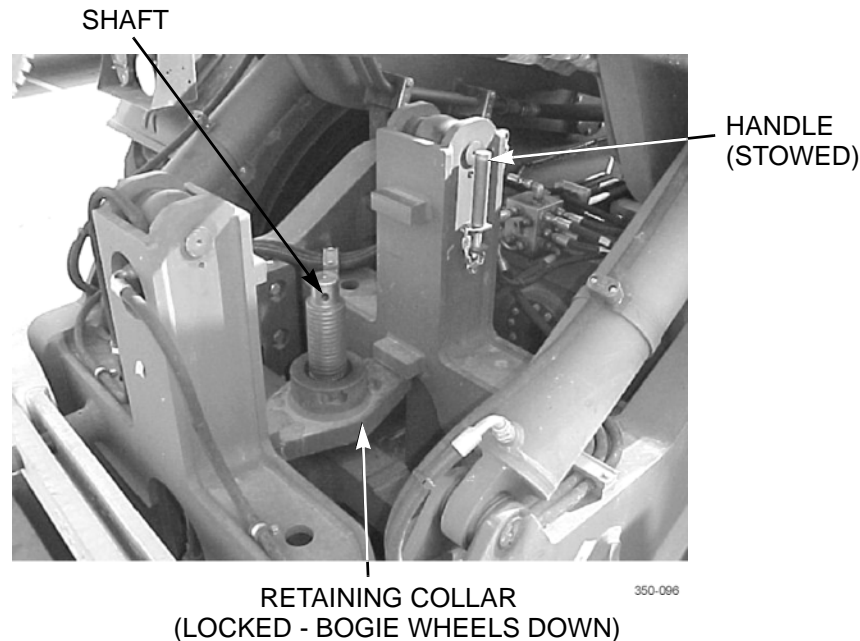

- y. Close bogie wheel pressure valve by turning handle 90 degrees clockwise.
- z. Shut down RTCH engine.
- aa. Tie boom to RTCH frame.
- ab. Secure RTCH to tiedown locations inside aircraft IAW tiedown instructions on RTCH data plate and on aircraft.
2. **Unload RTCH from C-5 or C-17 Aircraft.**
- a. Remove all tiedowns.
- b. Open bogie wheel pressure valve inside remote hydraulic control compartment by turning handle 90 degrees counter-clockwise.
- c. Rotate bogie wheel retaining collar $\frac{1}{4}$ turn clockwise to unlock bogie wheels.
- d. Raise boom support to 30-degree mark on frame. Refer to *Placing Boom Support in Transport Position* in this work package.

WARNING

Always use a ground guide (load master) and DO NOT exceed 1 mph (1.6 kph) when backing RTCH down aircraft ramps. Failure to use a ground guide may result in an accident, causing death or injury to personnel or damage to equipment.

CAUTION

Oversteering will damage dolly and bogie wheels.

- e. Use 2-wheel steering mode to slowly back RTCH down ramps. DO NOT exceed 1 mph (1.6 kph) speed. Only slight steering corrections (no more than $\frac{1}{4}$ turn of steering wheel) are allowed during unloading.
- f. Inside remote hydraulic control compartment, close bogie wheel pressure valve.
- g. Inside remote hydraulic control compartment, pull bogie wheel lever to fully raise bogie wheels.

AIR TRANSPORT - CONTINUED

- h. Turn bogie wheel retaining collar ¼ turn clockwise and lower bogie wheels to lock in stowed position.
- i. At front of machine, close both shutoff valves #6.

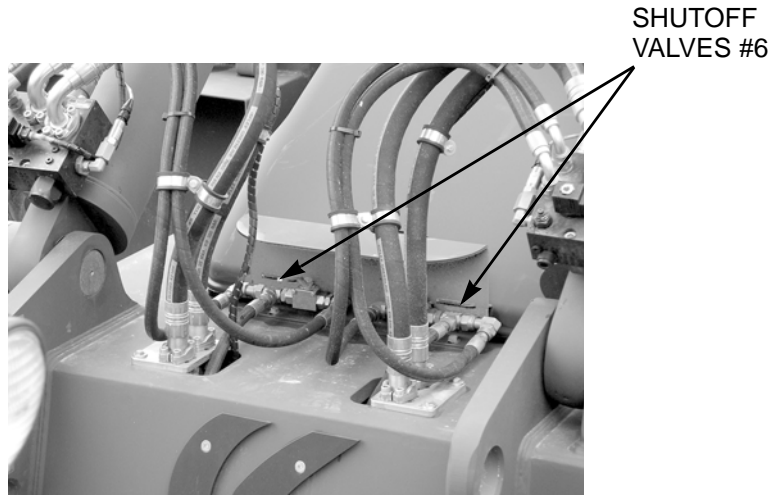

374-0030M

- j. At side of locking valve at base of each lift cylinder, loosen float valve jamnut and turn float valve clockwise until tight. Retighten jamnut.

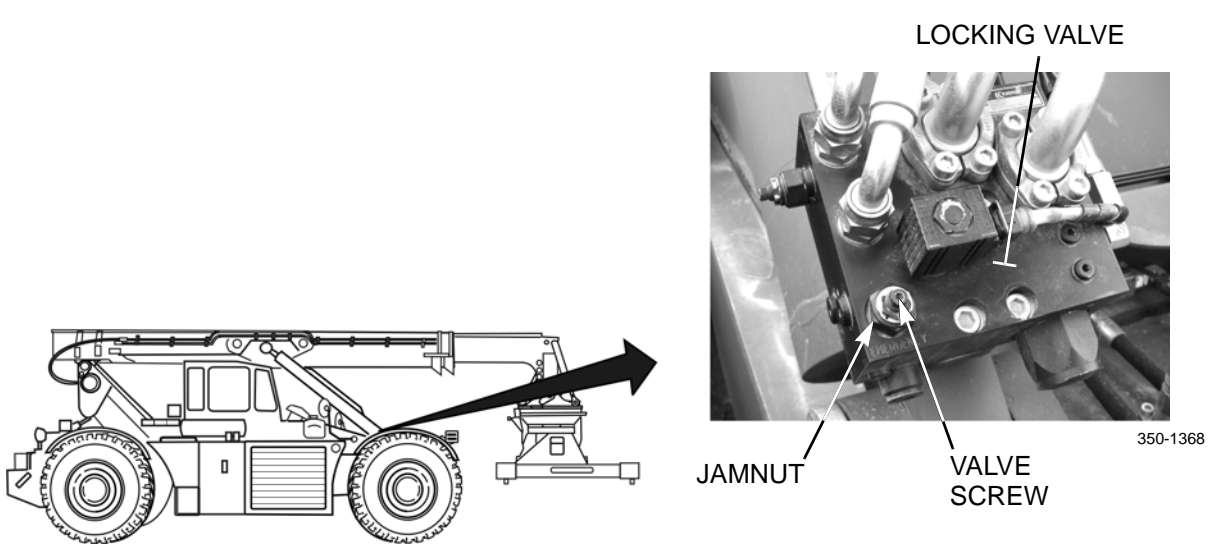

AIR TRANSPORT - CONTINUED**WARNING**

Ensure that tabs on ramp are engaged into ramp seat holes in dolly wheel storage compartment. Failure to secure ramp properly may cause ramp to fall under weight of dolly wheel, causing injury to personnel.

- k. Raise boom until dolly wheels are off the ground. Remove dolly wheels from tophandler. Remove lower retaining pin from each dolly wheel and lower tophandler until dolly wheels are on the ground. Remove upper pin from each dolly wheel to allow it to be removed from tophandler.

CAUTION

To ensure tophandler does not contact underside of boom, exercise tilt function while rotating tophandler. Failure to do so may damage tophandler and/or boom.

- l. Rotate tophandler 90 degrees counterclockwise to operational position.
- m. Raise boom to approximately 12 to 13 ft (3.66 to 3.96 m) height.
- n. Raise boom support. Refer to *Placing Boom Support in Transport Position* in this work package.
- o. Return cab to operational position. Refer to *Placing Cab in Transport Position* in this work package.
- p. Shut down RTCH engine.
- q. Fill fuel tank (WP 0015 00).

END OF WORK PACKAGE

INTRODUCTION

- a. This work package describes the locations for stowage of equipment and material required to be carried on the RTCH-RT 240V2.
- b. This work package also includes illustrations showing the location of all decals, data plates, and stencils.

STOWAGE GUIDE**NOTE**

Items listed in Table 1 are illustrated in WP 0017 00, Components of End Item (COEI) and Basic Issue Items (BII) Lists.

Table 1. Stowage Guide.

ITEM	NOMENCLATURE	QTY	STOWAGE LOCATION
1	Extinguisher, Fire	1	Mount in bracket inside cab.
2	Ladder/Handrail	1	During normal operation, mount as a handrail on left side of stairs on left side of machine. May be mounted as a ladder on left, right, front, or rear of vehicle.
3	Ramp, Dolly Wheels	1	Stow inside dolly wheel storage compartment.
4	Tool Kit	1	Stow inside cab.
5	Wheel, Dolly	4	Stow inside dolly wheel storage compartment.
6	Transport Boom Rest	1	Stow inside rear bumper with bolts provided when not in use.

CAB DECALS

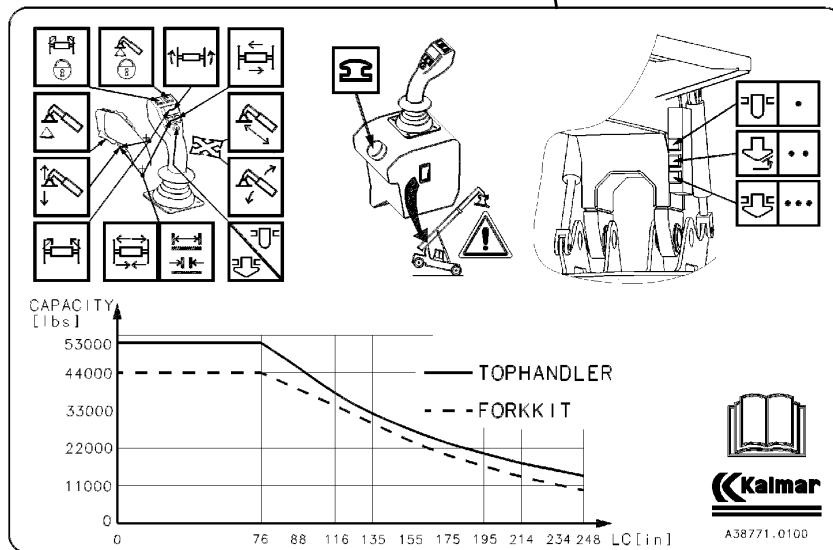
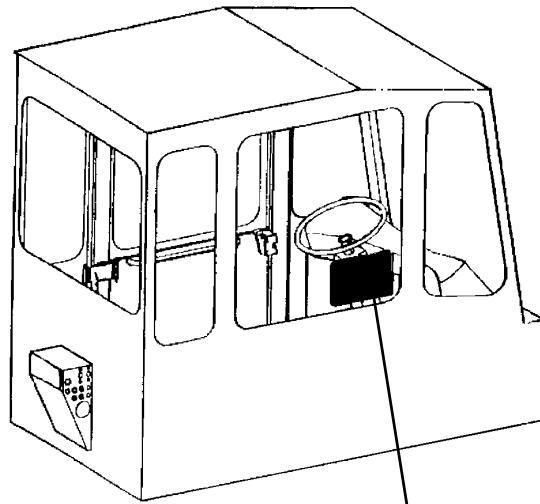

350-100

CAB DECALS - CONTINUED

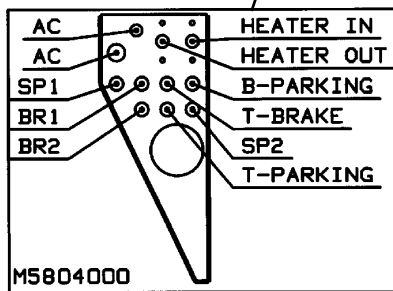
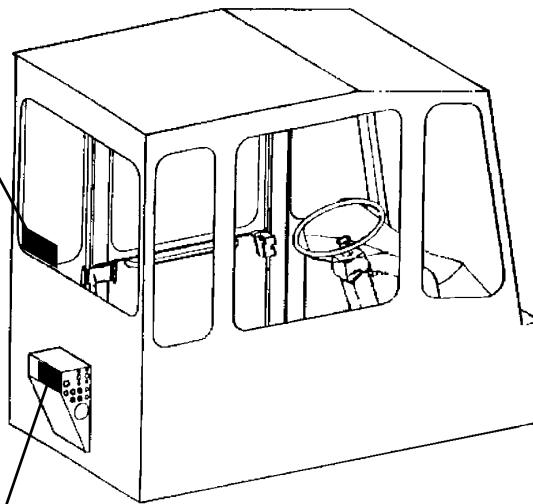

350-904

CAB DECALS - CONTINUED

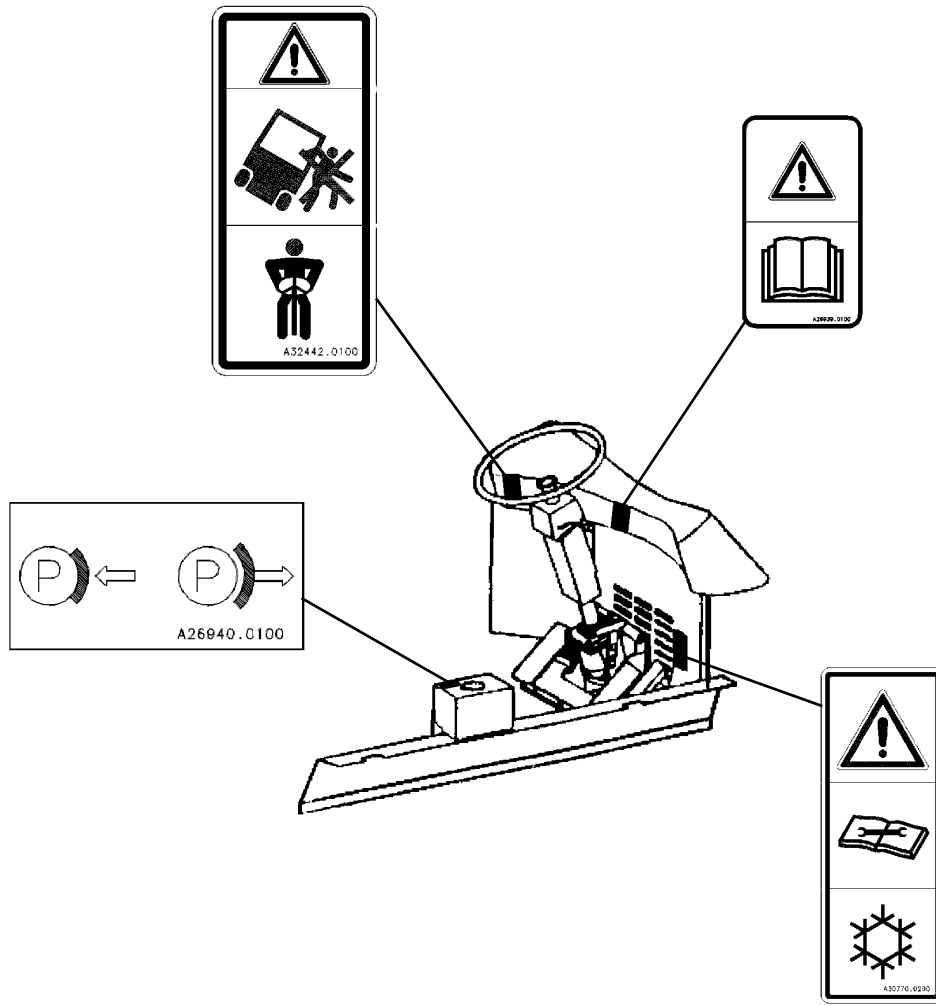

350-905

CAB DECALS - CONTINUED

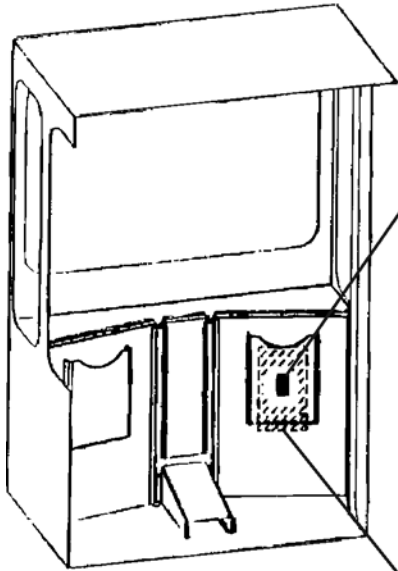

NO	DESCRIPTION
1	CONDENSER
2	INTERIOR LIGHT, FLASHER RELAY, IR-LIGHT
3	SEAT BUZZER, INCHING, SENSORS FOR BRAKE PRESSURE/P-BRAKE
4	CONTROL UNIT 794:ENGINE
5	CONTROL UNIT 794:ENGINE
6	DIRECTION INDICATOR, FRONT WIPER RETURN CURRENT, ARTIC KIT SWITCH (OPTIONAL)
7	CONTROL LIGHT FOR CHARGING AND P-BRAKE, FUEL GAUGE
8	GEAR SHIFTING
9	FRONT WINDOW WIPER
10	BRAKE LIGHT SENSOR, BACK-UP LIGHT, BACK-UP ALARM
11	FAN, AC, RECIRCULATION CONTROL
12	WORK LIGHT BOOM
13	ENGINE SHUT OFF
14	ADDITIONAL POWER SOURCE, 24V AND 12V
15	REAR WINDOW WIPER, ROOF WINDOW WIPER
16	POWER SUPPLY HEAD LIGHTS AND BLACKOUT LIGHTS
17	CONTROL CURRENT: WORKING LIGHT SPREADER, AUXILIARY HYDRAULIC PUMP, ETHER START
18	LEFT HEAD LIGHT
19	RIGHT HEAD LIGHT
20	LEFT DIM LIGHT
21	RIGHT DIM LIGHT
22	RIGHT REAR TAIL LIGHT, FRONT SIDE MARKER LIGHTS
23	LEFT REAR TAIL LIGHT, REAR SIDE MARKER LIGHTS
24	LEFT FRONT BLACKOUT HEAD LIGHT
25	TAIL AND FRONT BLACKOUT LIGHTS
26	CONTROL UNIT 792:STEERING
27	CONTROL UNIT 793:TRANSMISSION
28	CONTROL UNIT 793:TRANSMISSION
29	CONTROL UNIT 792:STEERING
30	CONTROL UNIT 790:MAIN ECM
31	CONTROL UNIT 795:DISPLAY
32	CONTROL UNIT 790:MAIN ECM
33	CAB POSITION, FORDING SWITCH, STEERING PRESSURE
34	OPTIONAL
POSITIONED IN CONNECTION BOX AT THE FRONT OF THE BOOM	
41	CONTROL UNIT 791:TOP HANDLER ECM
42	TOP HANDLER SENSORS
43	TOP HANDLER WORKING LIGHTS
POSITIONED AT ENGINE	
MAIN CIRCUIT BREAKERS BEFORE KEY AFTER KEY	
AUXILIARY HYDRAULIC PUMP POWER SUPPLY	
POSITIONED AT AUXILIARY HYDRAULIC PUMP	
TOP HANDLER POWER SUPPLY	

374M-0016

CHASSIS DECALS, PLATES, AND STENCILS

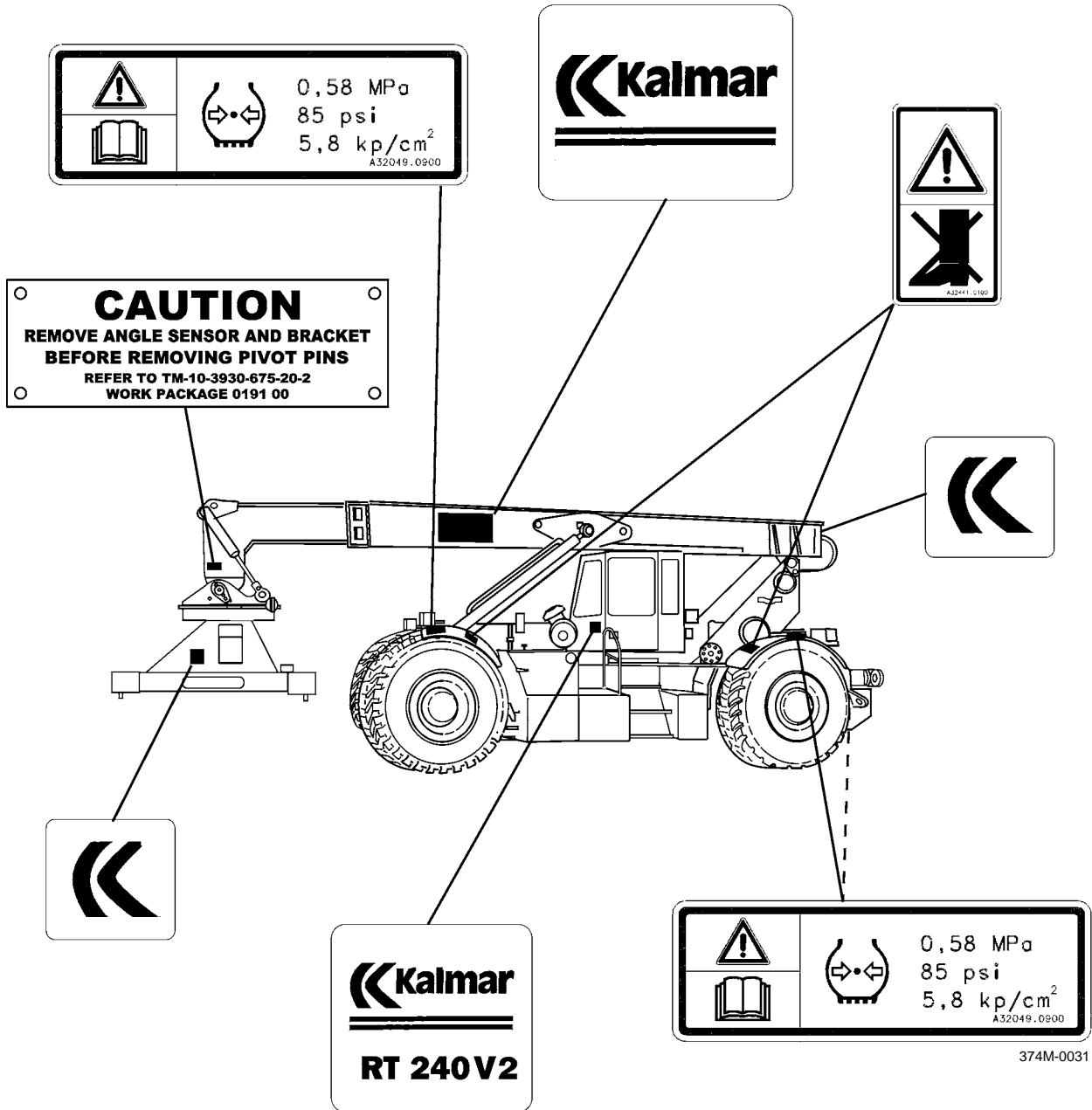

CHASSIS DECALS, PLATES, AND STENCILS - CONTINUED

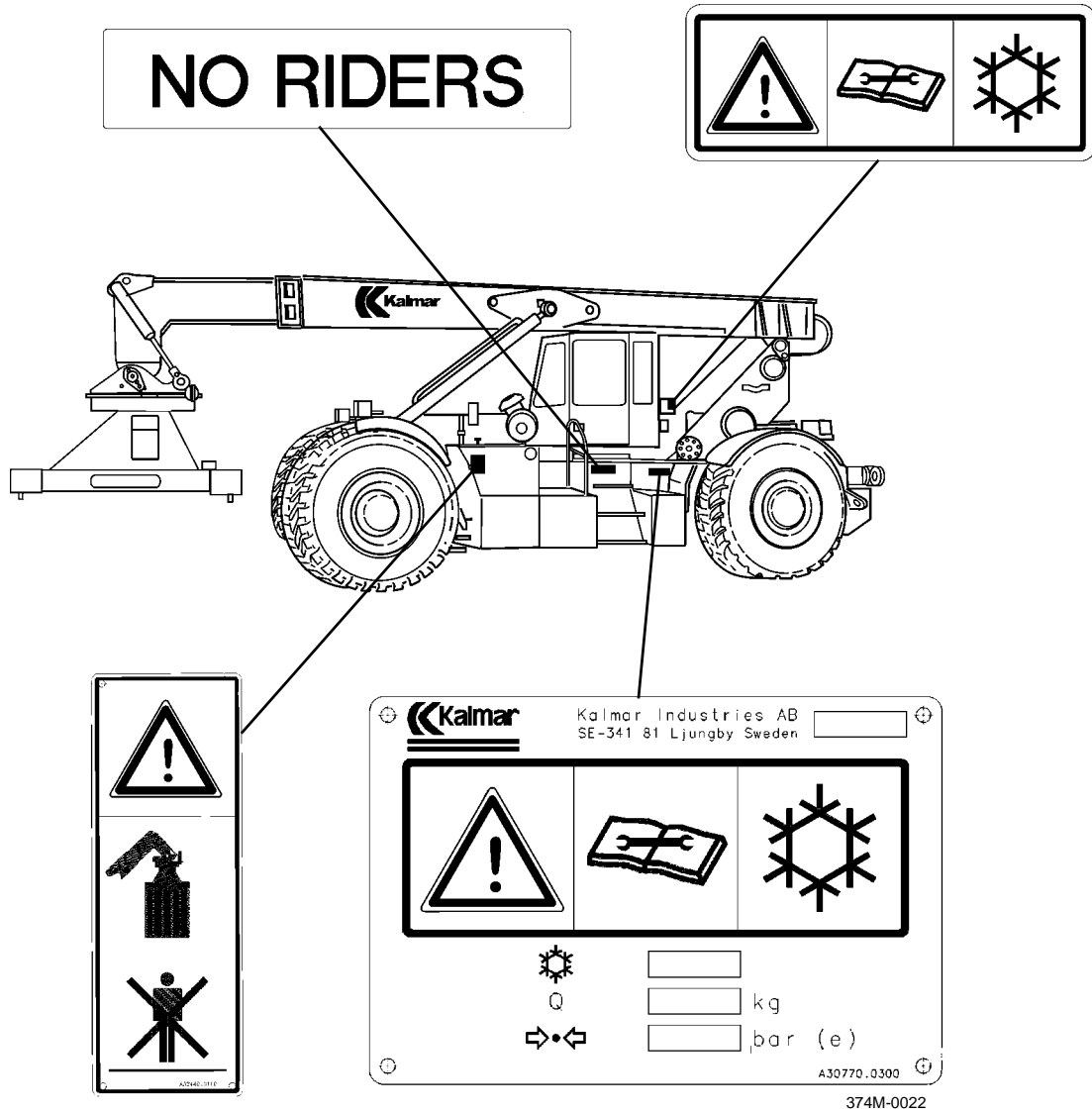

CHASSIS DECALS, PLATES, AND STENCILS - CONTINUED

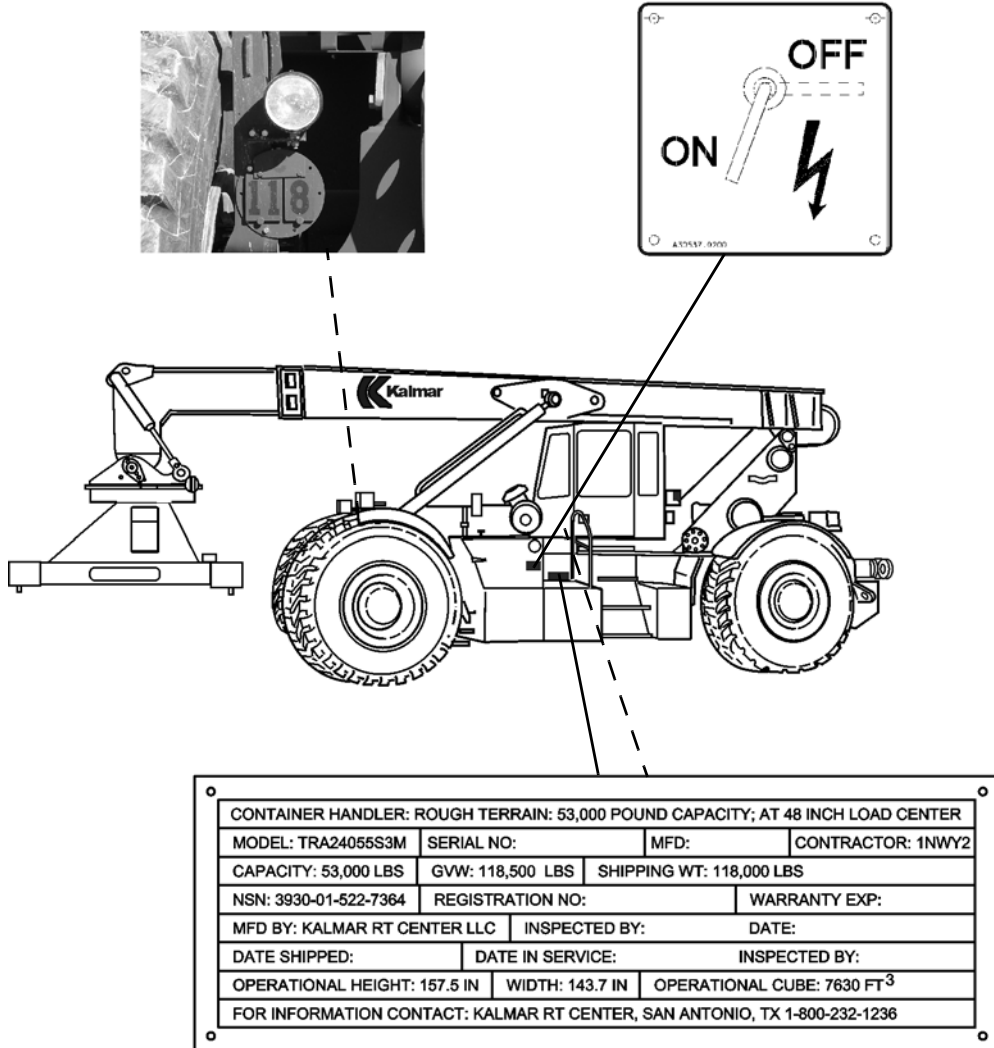

374M-0033

CHASSIS DECALS, PLATES, AND STENCILS - CONTINUED

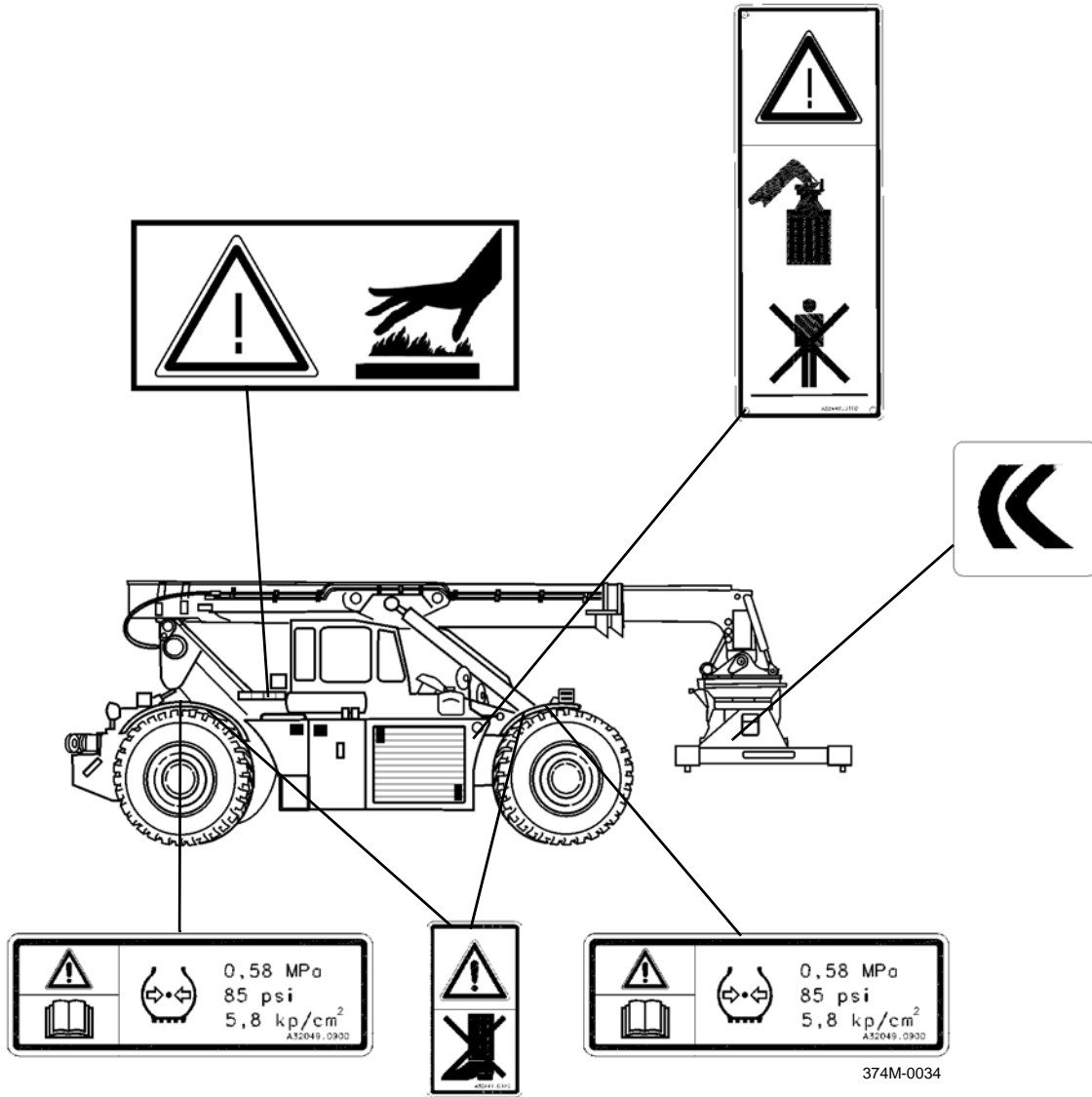

CHASSIS DECALS, PLATES, AND STENCILS - CONTINUED

LOCATED ON FAN CASING

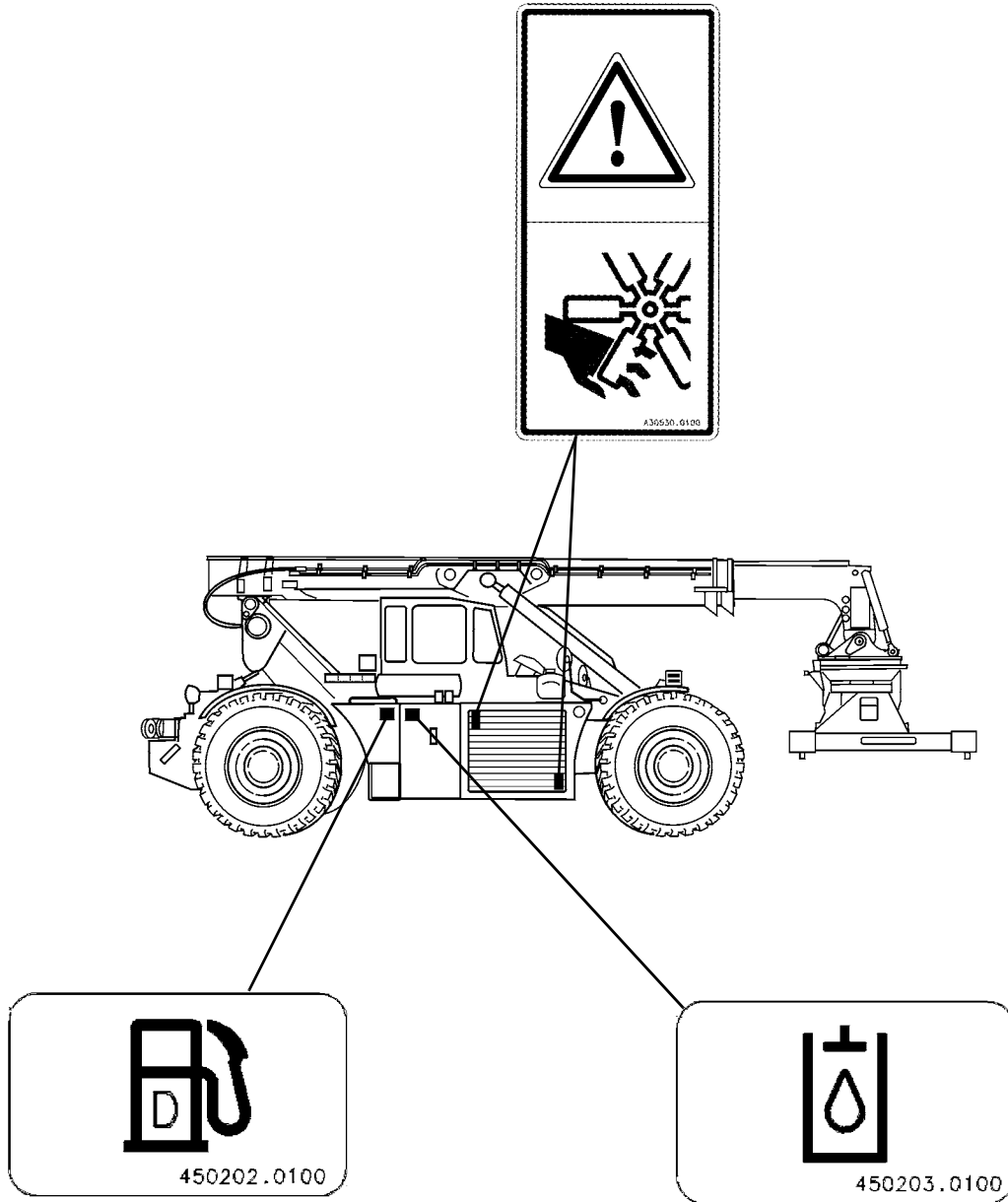

374M-0035

CHASSIS DECALS, PLATES, AND STENCILS - CONTINUED

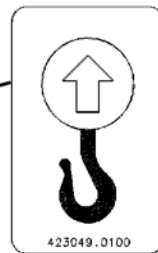
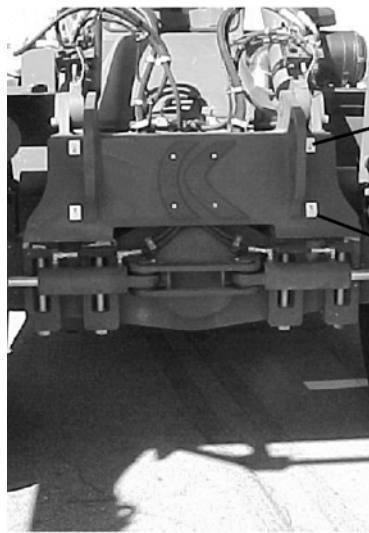

LOCATED AT
EACH LIFT
POINT

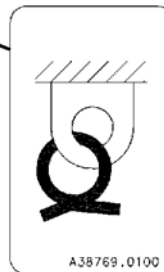

LOCATED AT
EACH TIEDOWN
POINT

374M-0018

CHASSIS DECALS, PLATES, AND STENCILS - CONTINUED

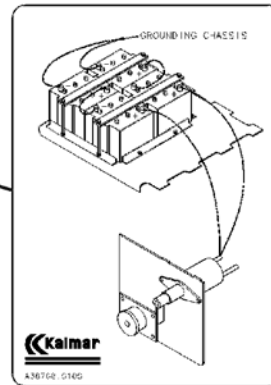
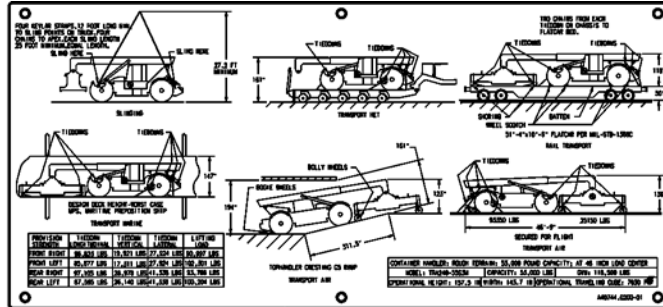

LUBRICATION DATA PLATE FOR MOON TERRAIN CONTAINER HANDLER, 55,000 POUND CAPACITY, 454
 MNI: 3920-01-522-7384

NO.	DESCRIPTION	QTY	GRADE	NOTE
1	ENGINE OIL	1	SAE 15W-40	USE ONLY APPROVED GRADES
2	HYDRAULIC OIL	1	SAE 46	USE ONLY APPROVED GRADES
3	STEERING OIL	1	SAE 46	USE ONLY APPROVED GRADES
4	WHEEL BEARING OIL	1	SAE 30	USE ONLY APPROVED GRADES
5	WHEEL HUB OIL	1	SAE 30	USE ONLY APPROVED GRADES
6	WHEEL AXLE OIL	1	SAE 30	USE ONLY APPROVED GRADES
7	WHEEL TIRE OIL	1	SAE 30	USE ONLY APPROVED GRADES
8	WHEEL BRACKET OIL	1	SAE 30	USE ONLY APPROVED GRADES
9	WHEEL HUB OIL	1	SAE 30	USE ONLY APPROVED GRADES
10	WHEEL AXLE OIL	1	SAE 30	USE ONLY APPROVED GRADES
11	WHEEL TIRE OIL	1	SAE 30	USE ONLY APPROVED GRADES
12	WHEEL BRACKET OIL	1	SAE 30	USE ONLY APPROVED GRADES
13	WHEEL HUB OIL	1	SAE 30	USE ONLY APPROVED GRADES
14	WHEEL AXLE OIL	1	SAE 30	USE ONLY APPROVED GRADES
15	WHEEL TIRE OIL	1	SAE 30	USE ONLY APPROVED GRADES
16	WHEEL BRACKET OIL	1	SAE 30	USE ONLY APPROVED GRADES
17	WHEEL HUB OIL	1	SAE 30	USE ONLY APPROVED GRADES
18	WHEEL AXLE OIL	1	SAE 30	USE ONLY APPROVED GRADES
19	WHEEL TIRE OIL	1	SAE 30	USE ONLY APPROVED GRADES
20	WHEEL BRACKET OIL	1	SAE 30	USE ONLY APPROVED GRADES

374M-0036

CHASSIS DECALS, PLATES, AND STENCILS - CONTINUED



DO NOT ATTEMPT TO OPERATE THE BOOM SUPPORT SYSTEM IF YOU ARE NOT TRAINED IN CORRECT OPERATING PROCEDURES. IF YOU ATTEMPT TO OPERATE IT, SEVERE DAMAGE MAY RESULT.

THE LAST STEP BEFORE LOCKING OR UNLOCKING THE BOOM SUPPORT LOCKING PINS WITH THE BOOM SUPPORT IN THE RAISED POSITION IS TO PULL ON THE TALL CENTER LEVER FOR A COUNT OF THREE. FAILURE TO DO THIS COULD RESULT IN A MISSION DISABLING FAILURE.

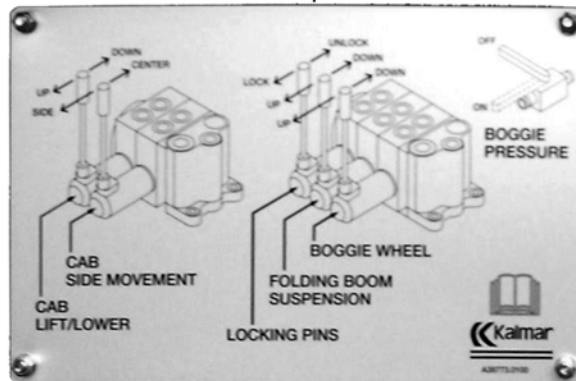

374-0047

CHASSIS DECALS, PLATES, AND STENCILS - CONTINUED

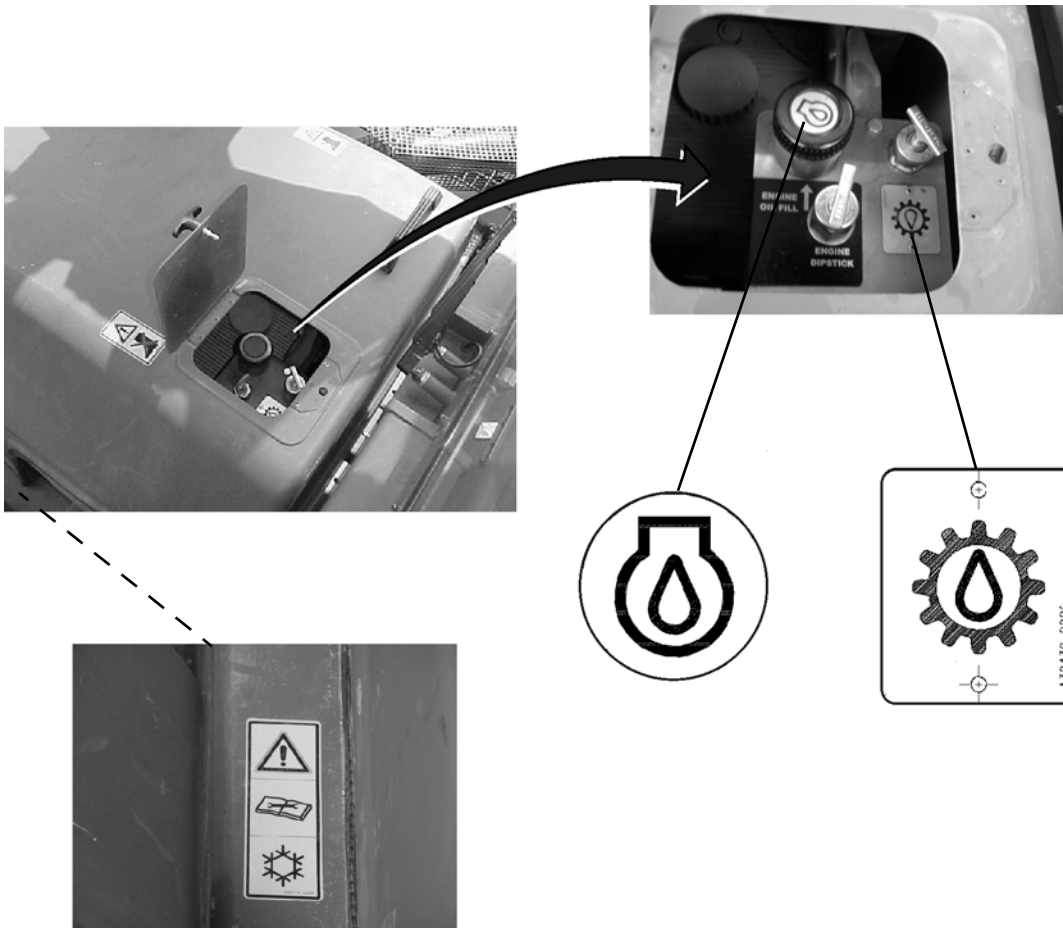

374M-0037

CHASSIS DECALS, PLATES, AND STENCILS - CONTINUED

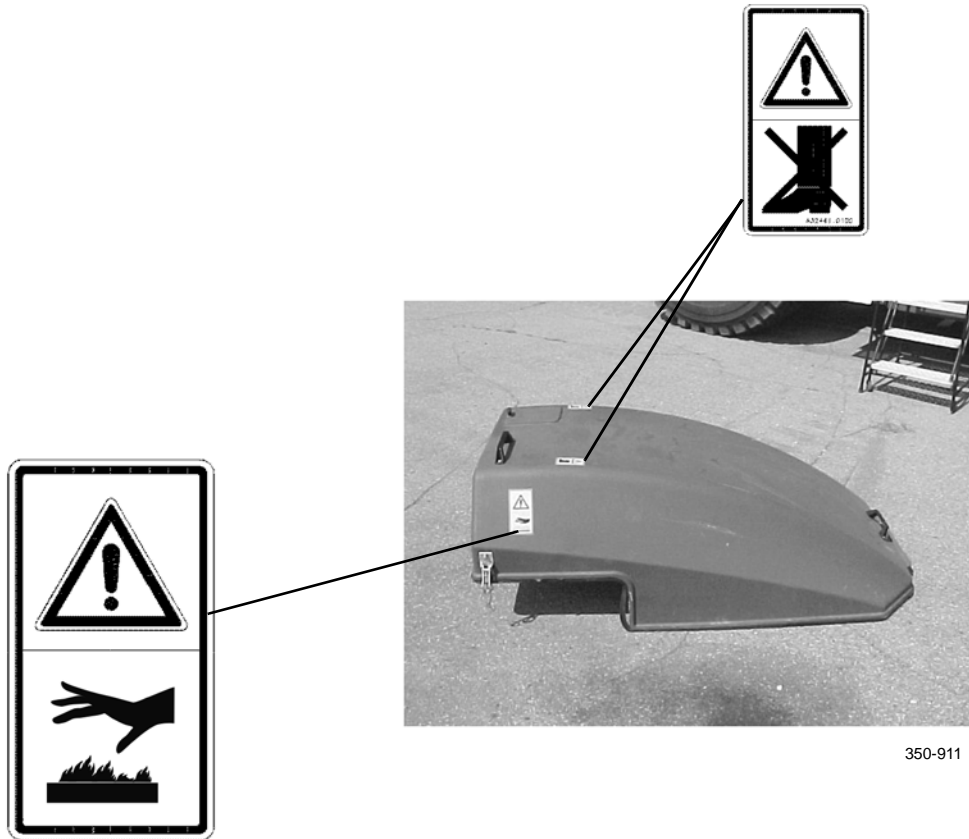

350-911

CHASSIS DECALS, PLATES, AND STENCILS - CONTINUED

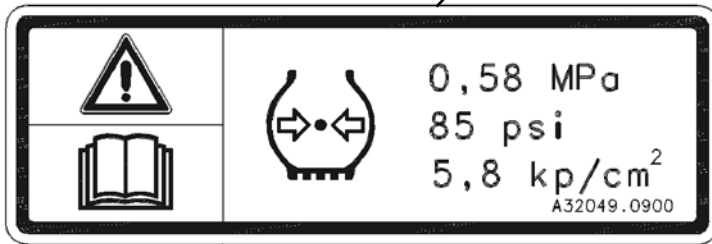

350-912

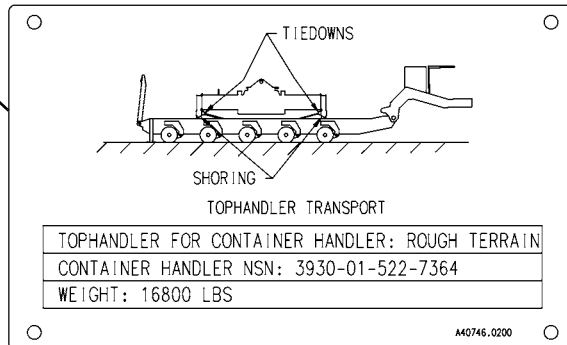
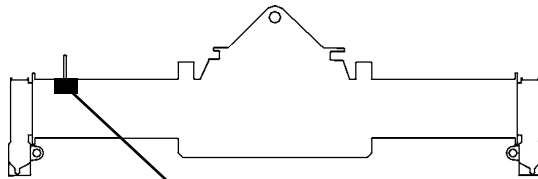

374M-0039

CHASSIS DECALS, PLATES, AND STENCILS - CONTINUED

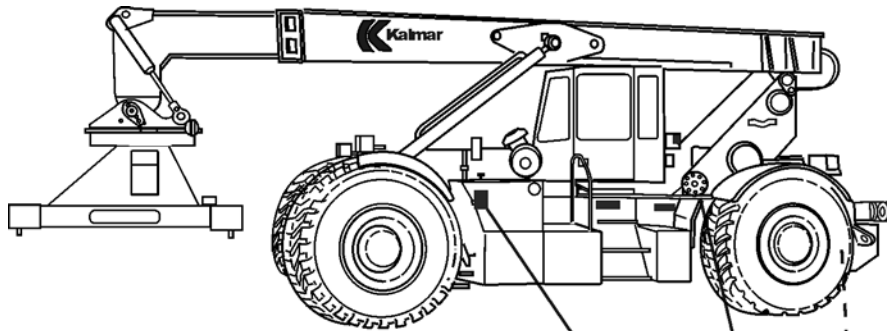

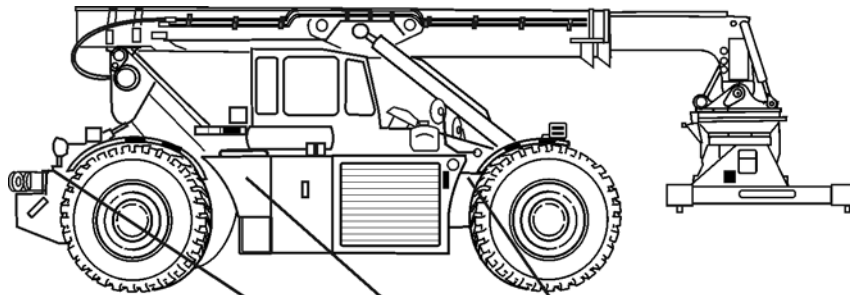

374M-0046

CHASSIS DECALS, PLATES, AND STENCILS - CONTINUED



374M-0047

FORKLIFT PLATES

		Kalmar Industries AB SE-341 81 Ljungby Sweden
	A	<input type="text"/>
	S/N	<input type="text"/>
	W	<input type="text"/> lbs
	Q	<input type="text"/> lbs
	D	<input type="text"/> in
	H	<input type="text"/> post
		A33853.0200

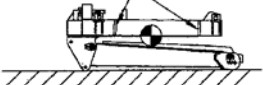
SLINGING & TIEDOWN PROVISIONS	
	
FORKLIFT KIT FOR CONTAINER HANDLER: ROUGH TERRAIN	
FORKLIFT KIT NSN: 3930-01-479-1624	WEIGHT: 11,600 LBS
CAPACITY FOR KALMAR RT240 RTCH: 44,000 LBS @ 48" LC	
WARRANTY EXP:	SERIAL NUMBER:



374M-0040

END OF WORK PACKAGE

CHAPTER 3
OPERATOR TROUBLESHOOTING

GENERAL**NOTE**

If an error code appears on driver's ECS display screen during operation, refer to WP 0020 00 for further information.

1. This chapter provides information for identifying and correcting malfunctions that may develop while operating the RTCH-RT 240V2.
2. The *Troubleshooting Symptom Index* in WP 0010 00 lists common malfunctions that may occur and refers you to the proper page in WP 0011 00, Table 1, for a troubleshooting procedure.
3. The Troubleshooting Symptom Index cannot list all malfunctions that may occur nor all tests or inspections and corrective actions. If a malfunction is not listed or is not corrected by the listed corrective actions, notify your supervisor.
4. If you are unsure of the location of an item mentioned in troubleshooting, refer to WP 0002 00 or WP 0004 00.
5. Before performing troubleshooting, read and follow all safety instructions found in the Warning Summary at the front of this manual.
6. When troubleshooting a malfunction:
 - a. Locate the symptom or symptoms in WP 0010 00 that best describe the malfunction.
 - b. Turn to the page in WP 0011 00, Table 1, where the troubleshooting procedures for the malfunction in question are described. Headings at the top of each page show how each troubleshooting procedure is organized: SYMPTOM, MALFUNCTION, and CORRECTIVE ACTION.
 - c. Perform each step in the order listed until the malfunction is corrected. DO NOT perform any maintenance task unless the troubleshooting procedure tells you to do so.

EXPLANATION OF COLUMNS

The columns in WP 0011 00, Table 1, are defined as follows:

1. **SYMPTOM**. Indicates fault that has occurred in system/equipment.
2. **MALFUNCTION**. Indicates probable cause for fault symptom.
3. **CORRECTIVE ACTION**. Indicates procedure to correct the problem.

END OF WORK PACKAGE

TROUBLESHOOTING SYMPTOM INDEX

0010 00

Malfunction/Symptom

Troubleshooting Procedure Page

Brake System

Poor or Erratic Braking Control0011 00-5

Engine

Engine:

Low On Power.....0011 00-2

Overheats.....0011 00-3

Runs Rough.....0011 00-2

Starts but Will Not Keep Running.....0011 00-1

Will Not Start.....0011 00-1

Low Engine Oil Pressure.....0011 00-4

Steering System

Erratic or No Steering Control0011 00-5

Transmission

Slow or No Transmission Functions.....0011 00-4

Twistlock Misalignment/Boom Lift Lockout

Twistlock Misalignment/Boom Lift Lockout0011 00-6

NOTE

Whenever the ECS display screen indicates a fault code, shut down engine, then restart engine. If fault code persists, notify Organizational Maintenance.

END OF WORK PACKAGE

Table 1. Troubleshooting Procedures.

ENGINE WILL NOT START**SYMPTOM**

Engine will not crank or cranks slowly.

MALFUNCTION

Ensure master battery switch is in ON position.

CORRECTIVE ACTION

Turn master battery switch to ON position.

Check for loose or disconnected battery cables.

CORRECTIVE ACTION

If cables or connectors are loose, broken, or disconnected, notify Organizational Maintenance.

Battery charging error code indicates low voltage.

Batteries low or discharged.

CORRECTIVE ACTION

Attempt to slave start machine (WP 0006 00) and notify Organizational Maintenance.

Engine cranks but will not start.

Fuel tank is empty or low on fuel.

CORRECTIVE ACTION

Fill fuel tank (WP 0015 00).

Fuel/water separator contains water or is clogged.

CORRECTIVE ACTION

Drain fuel/water separator (*Weekly* PMCS, WP 0013 00).

ECS display screen indicates engine fault code(s).

Notify Organizational Maintenance.

ENGINE STARTS BUT WILL NOT KEEP RUNNING**SYMPTOM**

Engine stops running after starting.

MALFUNCTION

Fuel tank is empty or low on fuel.

CORRECTIVE ACTION

Fill fuel tank (WP 0015 00).

Fuel/water separator contains water or is clogged.

CORRECTIVE ACTION

Drain fuel/water separator (*Weekly* PMCS, WP 0013 00).

Table 1. Troubleshooting Procedures - Continued.

ENGINE STARTS BUT WILL NOT KEEP RUNNING - CONTINUED**MALFUNCTION**

Check fuel lines, connections, and filters for leakage, damage, or clogging.

CORRECTIVE ACTION

Notify Organizational Maintenance.

ECS display screen indicates engine fault code(s).

CORRECTIVE ACTION

Notify Organizational Maintenance.

ENGINE RUNS ROUGH**SYMPTOM**

Rough idling and misfires.

MALFUNCTION

Check for white or blue smoke, indicating engine is cold.

CORRECTIVE ACTION

Allow engine to reach normal operating temperature of 180° to 200°F (82° to 93°C).

Fuel/water separator contains water or is clogged.

CORRECTIVE ACTION

Drain fuel/water separator (*Weekly* PMCS, WP 0013 00).

Check fuel lines, connections, and filters for leakage or damage.

CORRECTIVE ACTION

Notify Organizational Maintenance.

ECS display screen indicates engine fault code(s).

CORRECTIVE ACTION

Notify Organizational Maintenance.

ENGINE LOW ON POWER**SYMPTOM**

Engine will not run at normal operating range of 1,800 to 2,100 RPM.

MALFUNCTION

Air cleaner is clogged or restricted.

CORRECTIVE ACTION

Check restriction indicator at outlet of air cleaner (WP 0014 00).

Service air cleaner assembly (WP 0014 00).

Check fuel lines, connections, and filters for leakage or damage.

CORRECTIVE ACTION

Notify Organizational Maintenance.

Table 1. Troubleshooting Procedures - Continued.

ENGINE LOW ON POWER - CONTINUED**MALFUNCTION**

Check for overfull engine oil level.

CORRECTIVE ACTION

Notify Organizational Maintenance.

ECS display screen indicates engine fault code(s).

CORRECTIVE ACTION

Notify Organizational Maintenance.

ENGINE OVERHEATS**WARNING**

DO NOT service cooling system unless engine has been allowed to cool down. **DO NOT** remove radiator cap. Add coolant only to expansion tank. This is a pressurized cooling system and escaping steam or hot coolant will cause serious burns.

SYMPTOM

Engine temperature exceeds 200°F (93°C).

MALFUNCTION

Check for low coolant level in the expansion tank.

CORRECTIVE ACTION

If low, add appropriate amount of coolant to the expansion tank (*After* PMCS, WP 0013 00).

Check cooling system for loose or leaking lines, hoses, and fittings.

CORRECTIVE ACTION

Notify Organizational Maintenance.

Check for obstructions and debris buildup on radiator fins and grille.

CORRECTIVE ACTION

If radiator fins and grille are obstructed, clean and remove obstructions.

Check for overfull engine oil level.

CORRECTIVE ACTION

Notify Organizational Maintenance.

ECS display screen indicates engine fault code(s).

CORRECTIVE ACTION

Notify Organizational Maintenance.

Table 1. Troubleshooting Procedures - Continued.

LOW ENGINE OIL PRESSURE**SYMPTOM**

Engine oil pressure at idle is below 10 psi (70 kPa) and/or below 30 psi (207 kPa) at 1,200 RPM.

MALFUNCTION

Check for low engine oil level.

CORRECTIVE ACTION

If oil level is low, add engine oil as required (*Before* PMCS, WP 0013 00).

Check for external oil leaks.

CORRECTIVE ACTION

If oil leaks are found, notify Organizational Maintenance.

ECS display screen indicates engine fault code(s).

CORRECTIVE ACTION

Notify Organizational Maintenance.

SLOW OR NO TRANSMISSION FUNCTIONS**SYMPTOM**

RTCH will not move in forward or reverse direction.

MALFUNCTION

Check to ensure parking brake is released.

CORRECTIVE ACTION

Release parking brake.

Check if transmission oil level is low.

CORRECTIVE ACTION

If transmission oil level is low, add oil as required (*After* PMCS, WP 0013 00).

ECS display screen indicates transmission fault code(s).

CORRECTIVE ACTION

Shut down engine and restart. If failure persists, notify Organizational Maintenance.

Transmission will not upshift or downshift properly.

Check if transmission oil level is low.

CORRECTIVE ACTION

If transmission oil level is low, add oil as required (*After* PMCS, WP 0013 00).

ECS display screen indicates transmission fault code(s).

CORRECTIVE ACTION

Shut down engine and restart. If failure persists, notify Organizational Maintenance.

Table 1. Troubleshooting Procedures - Continued.

ERRATIC OR NO STEERING CONTROL**SYMPTOM**

Steering system not responding to steering wheel movement.

MALFUNCTION

Ensure machine is in 2-wheel steering mode.

CORRECTIVE ACTION

Place machine in 2-wheel steering mode. Recheck steering.

Hydraulic system oil level is low.

CORRECTIVE ACTION

If hydraulic system reservoir oil level is low, add oil as required (*Before* PMCS, WP 0013 00).

ECS display screen indicates steering system fault code(s).

CORRECTIVE ACTION

Shut down engine and restart. If failure persists, notify Organizational Maintenance.

Steering system not responding to selection of 2-wheel, 4-wheel, or crab steering modes.

ECS display screen indicates steering system fault code(s).

CORRECTIVE ACTION

Shut down engine and restart. If failure persists, notify Organizational Maintenance.

POOR OR ERRATIC BRAKING CONTROL**SYMPTOM**

Brakes will not hold RTCH and/or brakes operate erratically.

MALFUNCTION

There are obstructions or debris buildup under brake pedal.

CORRECTIVE ACTION

Remove obstructions or debris.

ECS display screen indicates brake system fault code(s).

CORRECTIVE ACTION

Shut down engine and restart. If failure persists, notify Organizational Maintenance.

Parking brake will not hold RTCH.

CORRECTIVE ACTION

Chock vehicle wheels. Notify Organizational Maintenance.

Table 2. Non-Error Code Troubleshooting.**TWISTLOCK MISALIGNMENT/BOOM LIFT LOCKOUT****SYMPTOM**

Boom does not lift or boom will lift only while holding the override switch.
Twistlock indicator locked or unlocked light is not illuminated.

MALFUNCTION

Twistlocks are misaligned which locks out boom lift function.

CORRECTIVE ACTION

Press and hold override switch (WP 0004 00) and operate twistlock function at the same time to realign twistlocks to locked or unlocked position.

The red or green twistlock indicator light should illuminate and reactivate the boom lift function.

END OF WORK PACKAGE

CHAPTER 4
OPERATOR MAINTENANCE INSTRUCTIONS

GENERAL

To ensure that the RTCH-RT 240V2 is ready for operation at all times, it must be inspected on a regular basis so that defects may be found and corrected before they result in serious damage, equipment failure, or injury to personnel. Table 1 in WP 0013 00 contains systematic instructions on inspections, adjustments, and corrections to be performed by the operator/crew to keep your equipment in good operating condition and ready for its primary mission.

NOTE

This manual covers Army and USMC units with serial numbers ending in .0400 and above.

EXPLANATION OF TABLE ENTRIES

1. **Item Number (Item No.) Column.** Numbers in this column are for reference. When completing DA Form 5988-E (*Equipment Inspection and Maintenance Worksheet*), include the item number for the check/service indicating a fault. Item numbers also appear in the order that you must perform checks and services for the interval listed.
2. **Interval Column.** This column tells you when you must perform the procedure in the procedure column.
 - a. *Before* procedures must be done immediately before you operate the RTCH.
 - b. *During* procedures must be done while you are operating the RTCH.
 - c. *After* procedures must be done immediately after you have operated the RTCH.
 - d. *Weekly* procedures must be done once each week.
 - e. *Monthly* procedures must be done once each month.
3. **Location, Item to Check/Service Column.** This column provides the location and item to be checked or serviced. The item location is underlined.

NOTE

The WARNINGS and CAUTIONS appearing in your PMCS table should always be observed. WARNINGS and CAUTIONS appear before applicable procedures. You must observe these WARNINGS to prevent serious injury to yourself and others, and CAUTIONS to prevent your equipment from being damaged.

4. **Procedure Column.** This column gives the procedure you must perform to check or service the item listed in the *Item to Check/Service* column to know if the equipment is ready or available for its intended mission or for operation. You must perform the procedure at the time stated in the Interval column.
5. **Not Fully Mission Capable If Column.** Information in this column tells you what faults will keep your equipment from being capable of performing its primary mission. If you perform check/service procedures that show faults listed in this column, the equipment is not mission-capable. Follow standard operating procedures for maintaining the equipment or reporting equipment failure.

GENERAL PMCS PROCEDURES

1. Always perform PMCS in the same order so it gets to be a habit. Once you have had some practice, you will spot anything wrong in a hurry. If the RTCH does not perform as required, refer to the appropriate troubleshooting procedure in *Chapter 3*.
2. If anything looks wrong and you cannot fix it, write it on your DA Form 5988-E. If you find something seriously wrong, IMMEDIATELY report it to your supervisor.
3. Before performing preventive maintenance, read all the checks required for the applicable interval and prepare all the tools you need to make all the checks. You will always need a Rag, Wiping (Item 12, WP 0019 00) or two.

GENERAL PMCS PROCEDURES - CONTINUED**WARNING**

Solvent cleaning compound MIL-PRF-680 Type III is an environmentally compliant and low toxic material. However, it may be irritating to the eyes and skin. Use protective gloves and goggles. Use in well-ventilated areas. Keep away from open flames and other sources of ignition. Failure to do so may cause injury or death to personnel.

- a. **Keep It Clean.** Dirt, grease, oil, and debris get in the way and may cover up a serious problem. Clean as you work and as needed. Use Solvent, Dry Cleaning, Type III (Item 13, WP 0019 00) on all metal surfaces. Use Detergent, General Purpose, Liquid (Item 3, WP 0019 00) and water when you clean rubber, plastic, and painted surfaces.
- b. **Rust and Corrosion.** Check metal parts for rust and corrosion. If any bare metal or corrosion exists, clean and apply a light coat of Oil, Lubricating (Item 8, WP 0019 00). Report it to your supervisor.
- c. **Bolts, Nuts, and Screws.** Check bolts, nuts, and screws for obvious looseness, missing, bent, or broken condition. You cannot try them all with a tool, but look for chipped paint, bare metal, or rust around bolt heads. If you find one you think is loose, tighten it.
- d. **Welds.** Look for loose or chipped paint, rust, or gaps where parts are welded together. If you find a bad weld, report it to your supervisor.
- e. **Electrical Wires and Connectors.** Look for cracked or broken insulation, bare wires, and loose or broken connectors. Tighten loose connectors and ensure that the wires are in good condition.
- f. **Hoses and Fluid Lines.** Look for wear, damage, and signs of leaks. Ensure that clamps and fittings are tight. Wet spots indicate leaks, but a stain around a fitting or connector can also mean a leak. If a leak comes from a loose fitting or connector, tighten it. If something is broken or worn out, report it to your supervisor.
- g. **Fluid Leakage.** It is necessary for you to know how fluid leakage affects the status of your RTCH. The following are definitions of the types/classes of leakage you need to know to be able to determine the status of your RTCH. Learn and be familiar with them, and remember - when in doubt, notify your supervisor.

CAUTION

Operation is allowable with Class I and Class II leakage. **WHEN IN DOUBT, NOTIFY YOUR SUPERVISOR.** When operating with Class I or Class II leaks, check fluid levels more frequently. Class III leaks must be reported immediately to your supervisor. Failure to do this will result in damage to vehicle and/or components.

Leakage Definitions for PMCS

Class I	Leakage indicated by wetness or discoloration, but not great enough to form drops.
Class II	Leakage great enough to form drops, but not enough to cause drops to drip from the item being checked/inspected.
Class III	Leakage great enough to form drops that fall from the item being checked/inspected.

GENERAL LUBRICATION PROCEDURES

NOTE

- **Lubrication instructions contained in this PMCS are mandatory.**
- **Overall views of lubrications points are located at the end of this work package.**
- **Refer to FM 9-207 for lubrication in arctic operation.**

1. Included in this PMCS are lubrication services to be performed by the operator.
2. Lubrication intervals are based on normal operation. Lubricate more during constant use and less during inactive periods. Use correct grade of lubricant for seasonal temperature expected. Refer to *KEY* on page 0012 00-4.
3. For equipment under manufacturer’s warranty, hardtime intervals shall be followed. Shorten intervals if lubricants are known to be contaminated or if operation is under adverse conditions (e.g., longer than usual operating hours, extended idling periods, extreme dust, etc.).
4. Keep all lubricants in an environmental storage container and store in a clean, dry place away from extreme heat. Keep container covers clean and do not allow dust, dirt, or other foreign material to mix with lubricants. Keep lubrication equipment clean and ready for use. Clean top of container before opening.



WARNING



Solvent cleaning compound MIL-PRF-680 Type III is an environmentally compliant and low toxic material. However, it may be irritating to the eyes and skin. Use protective gloves and goggles. Use in well-ventilated areas. Keep away from open flames and other sources of ignition. Failure to do so may cause injury or death to personnel.

5. Clean area around lubrication points with Solvent, Dry Cleaning, Type III (Item 13, WP 0019 00) or equivalent before lubricating equipment. Keep all external parts of equipment not requiring lubrication free of lubricants. After lubrication, wipe off excess lubricant to prevent accumulation of foreign matter.
6. Maintain a record of lubrication performed and report any problems noted during lubrication. Refer to *DA PAM 750-8 for forms and procedures to record and report any findings.*
7. **Man-Hour Times.** The man-hour time specified is the time needed to perform all services prescribed for a particular interval. The man-hour times for the RTCH are as follows:

Interval	Man-Hour
Daily	0.5
Weekly	0.5
300 Hours	3.0
900 Hours	4.0

GENERAL LUBRICATION PROCEDURES - CONTINUED

KEY

Lubricant/ Component	Refill Capacity	Expected Temperatures*			Intervals
		+6°F to +122°F (-14°C to +50°C)	-4°F to +50°F (-20°C to +10°C)	-67°F to +32°F (-55°C to 0°C)	
OE/HDO (MIL-PRF-2104) Lubricating Oil, Tactical					D - Daily W - Weekly HR - Hours OC - On Condi- tion
OEA (MIL-L-46167) Lubricating Oil, ICE, Arctic					
Engine Crankcase w/ Filters	38.6 qt (36.5 L)	See Chart A			
Transmission	36 qt (34 L)	See Chart B			
Hydraulic System	180 gal. (680 L)	See Chart C			
GO (MIL-L-2105) Lubricating Oil, Gear, Multipurpose					
Front Axle Differential Housing	15.9 gal. (60 L)	See Chart D			
Front Axle Hub End	2.64 gal. (10 L)	See Chart D			
Rear Axle Differential Housing	11.1 gal. (42 L)	See Chart D			
Rear Axle Hub End	2.77 gal. (10.5 L)	See Chart D			
GAA (MIL-G-10924) Grease, Automotive and Artillery		All Temperatures			
ANTIFREEZE (MILA46153) Permanent, Ethylene Glycol, Inhibited, Heavy-Duty					
ANTIFREEZE (MILA11755) Permanent, Arctic Grade					
Engine Radiator	23.7 gal. (90 L)	See Chart E			

* For Arctic Operation, refer to FM 9-207.

GENERAL LUBRICATION PROCEDURES - CONTINUED

CHART A—ENGINE.

Lubricant	EXPECTED TEMPERATURES																			
	°F	-70	-60	-50	-40	-30	-20	-10	0	+10	+20	+30	+40	+50	+60	+70	+80	+90	+100	+120
	°C	-57	-51	-46	-40	-34	-29	-23	-18	-12	-7	-1	+4	+10	+16	+21	+27	+32	+38	+49
OE/HDO (MIL-PRF-2104)	Lubricating Oil, Tactical																			
OEA (MIL-L-46167)	Lubricating Oil, ICE, Arctic																			
OE/HDO-15/40																				
OE/HDO-10																				
OEA *																				

*If OEA lubricant is required to meet the low expected temperature range, OEA lubricant is to be used in lieu of OE/HDO-10 lubricant for all expected temperatures where OE/HDO-10 is specified.

CHART B—TRANSMISSION.

Lubricant	EXPECTED TEMPERATURES																			
	°F	-70	-60	-50	-40	-30	-20	-10	0	+10	+20	+30	+40	+50	+60	+70	+80	+90	+100	+120
	°C	-57	-51	-46	-40	-34	-29	-23	-18	-12	-7	-1	+4	+10	+16	+21	+27	+32	+38	+49
OE/HDO (MIL-PRF-2104)	Lubricating Oil, Tactical																			
OEA (MIL-L-46167)	Lubricating Oil, ICE, Arctic																			
OE/HDO-15/40																				
OEA																				

CHART C—HYDRAULIC, STEERING, AND BRAKE SYSTEM.

Lubricant	EXPECTED TEMPERATURES																			
	°F	-70	-60	-50	-40	-30	-20	-10	0	+10	+20	+30	+40	+50	+60	+70	+80	+90	+100	+120
	°C	-57	-51	-46	-40	-34	-29	-23	-18	-12	-7	-1	+4	+10	+16	+21	+27	+32	+38	+49
OE/HDO (MIL-PRF-2104)	Lubricating Oil, Tactical																			
OEA (MIL-L-46167)	Lubricating Oil, ICE, Arctic																			
OE/HDO-10																				
OEA																				

GENERAL LUBRICATION PROCEDURES - CONTINUED

CHART D—FRONT/REAR AXLE DIFFERENTIALS AND SLEWING MOTORS.

Lubricant	EXPECTED TEMPERATURES																			
	°F	-70	-60	-50	-40	-30	-20	-10	0	+10	+20	+30	+40	+50	+60	+70	+80	+90	+100	+120
	°C	-57	-51	-46	-40	-34	-29	-23	-18	-12	-7	-1	+4	+10	+16	+21	+27	+32	+38	+49
GO (MIL-L-2105)	Lubricating Oil, Gear, Tactical																			
GO 85W/140																				

CHART E—ANTIFREEZE.

Lubricant	EXPECTED TEMPERATURES																			
	°F	-90	-80	-70	-60	-50	-40	-30	-20	-10	0	+10	+20	+30	+40	+50	+60	+70	+80	+90
	°C	-68	-62	-57	-51	-46	-40	-34	-29	-23	-18	-12	-7	-1	+4	+10	+16	+21	+27	+32
MIL-A-46153	Antifreeze, Ethylene Glycol, Inhibited, Heavy-Duty																			
MIL-A-11755	Antifreeze, Arctic Grade																			
MIL-A-46153																				
MIL-A-11755																				

USMC or units with serial numbers ending .0400 or above

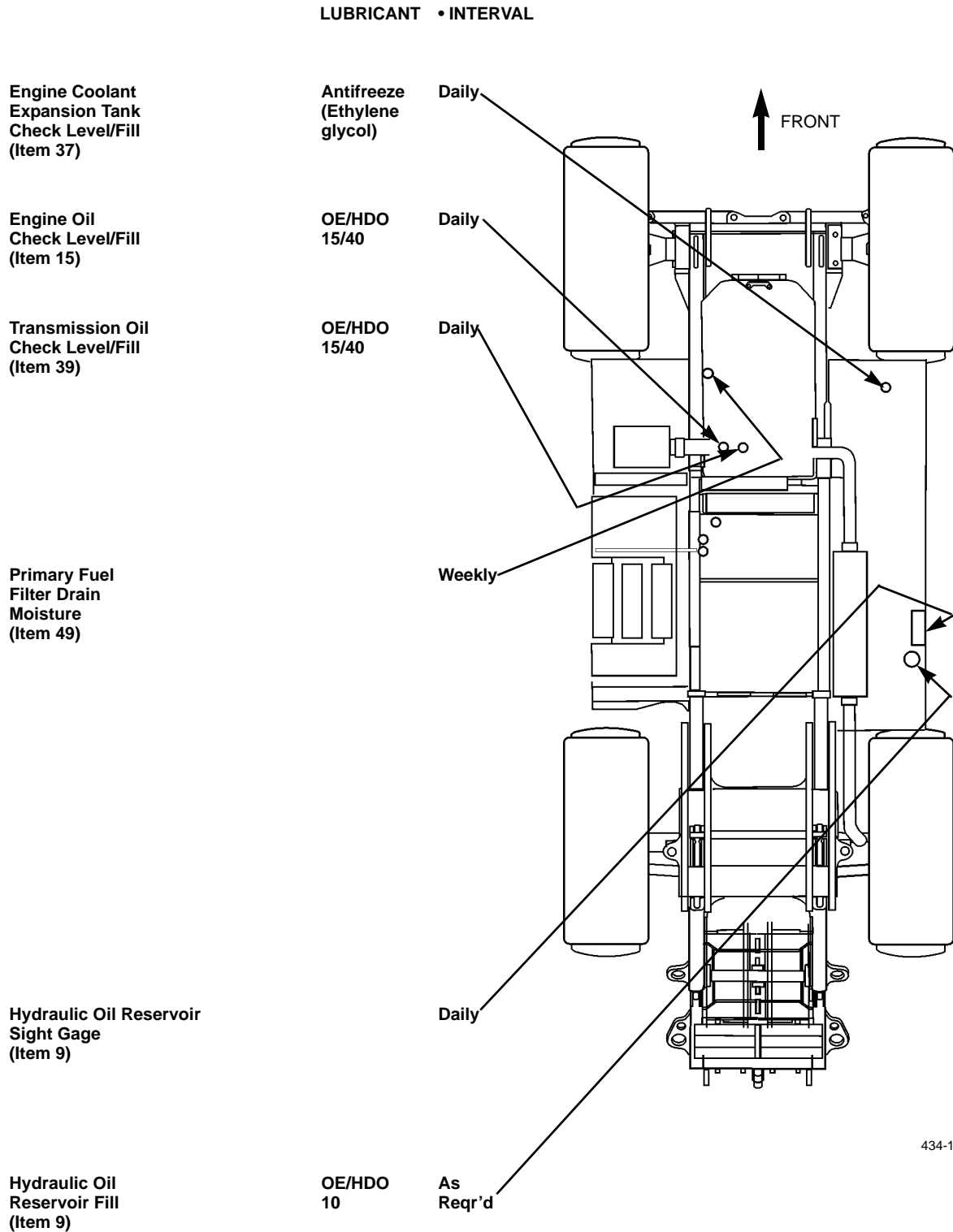

USMC or units with serial numbers ending .0400 or above

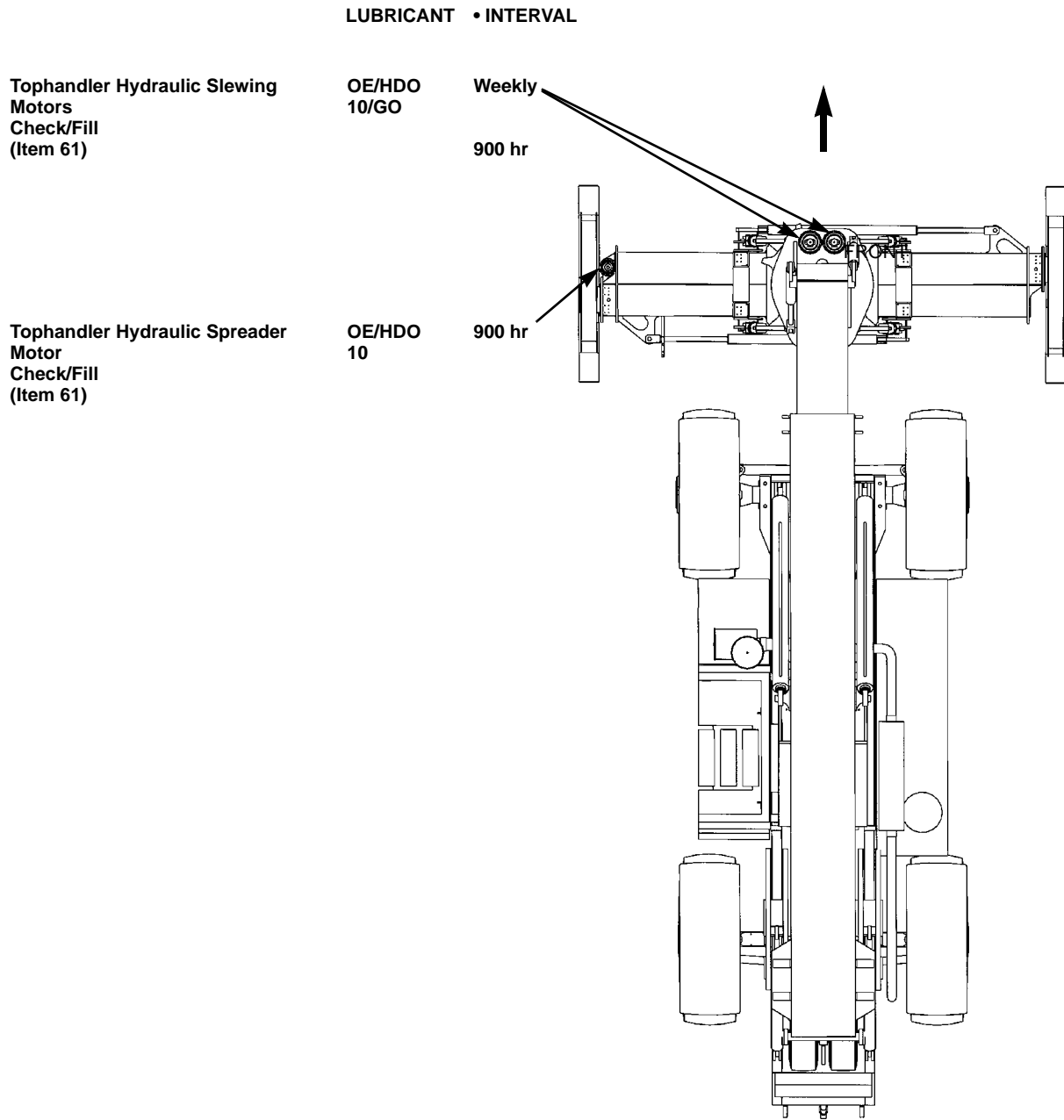

424-10010

USMC or units with serial numbers ending .0400 or above

LUBRICANT • INTERVAL

Primary Fuel
Filter
Drain Moisture
(Note 1)

Transmission Oil
Check Level/Fill
(Note 2)

OE/HDO
15/40

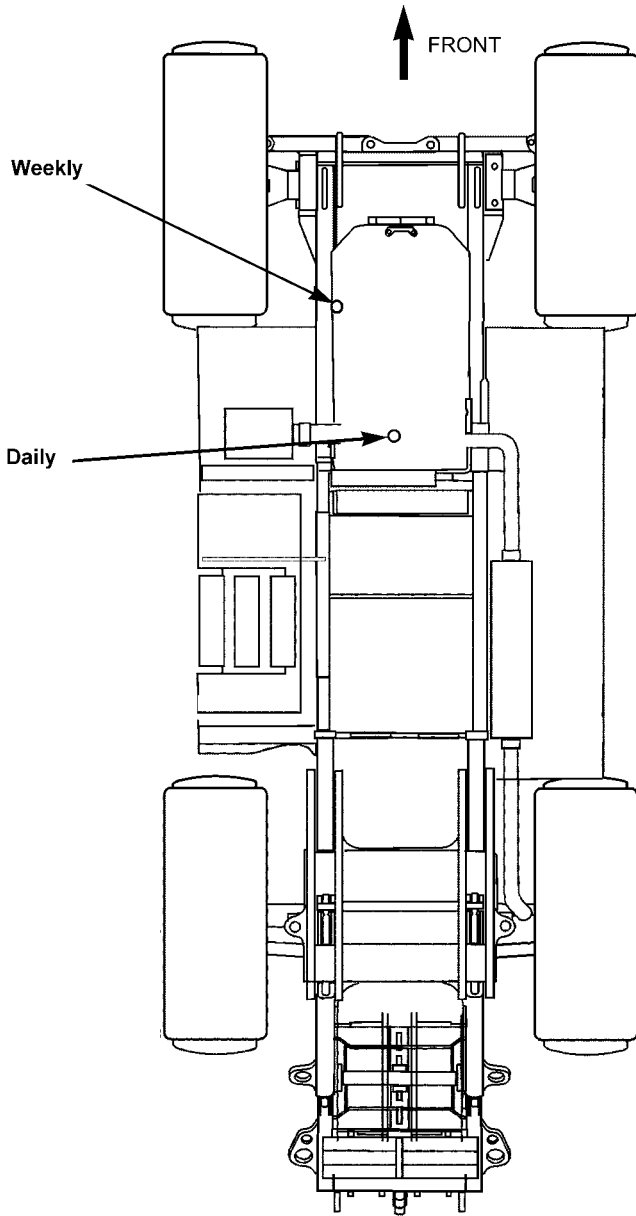

434-20016

■ **USMC or units with serial numbers ending .0400 or above**

LUBRICANT • INTERVAL

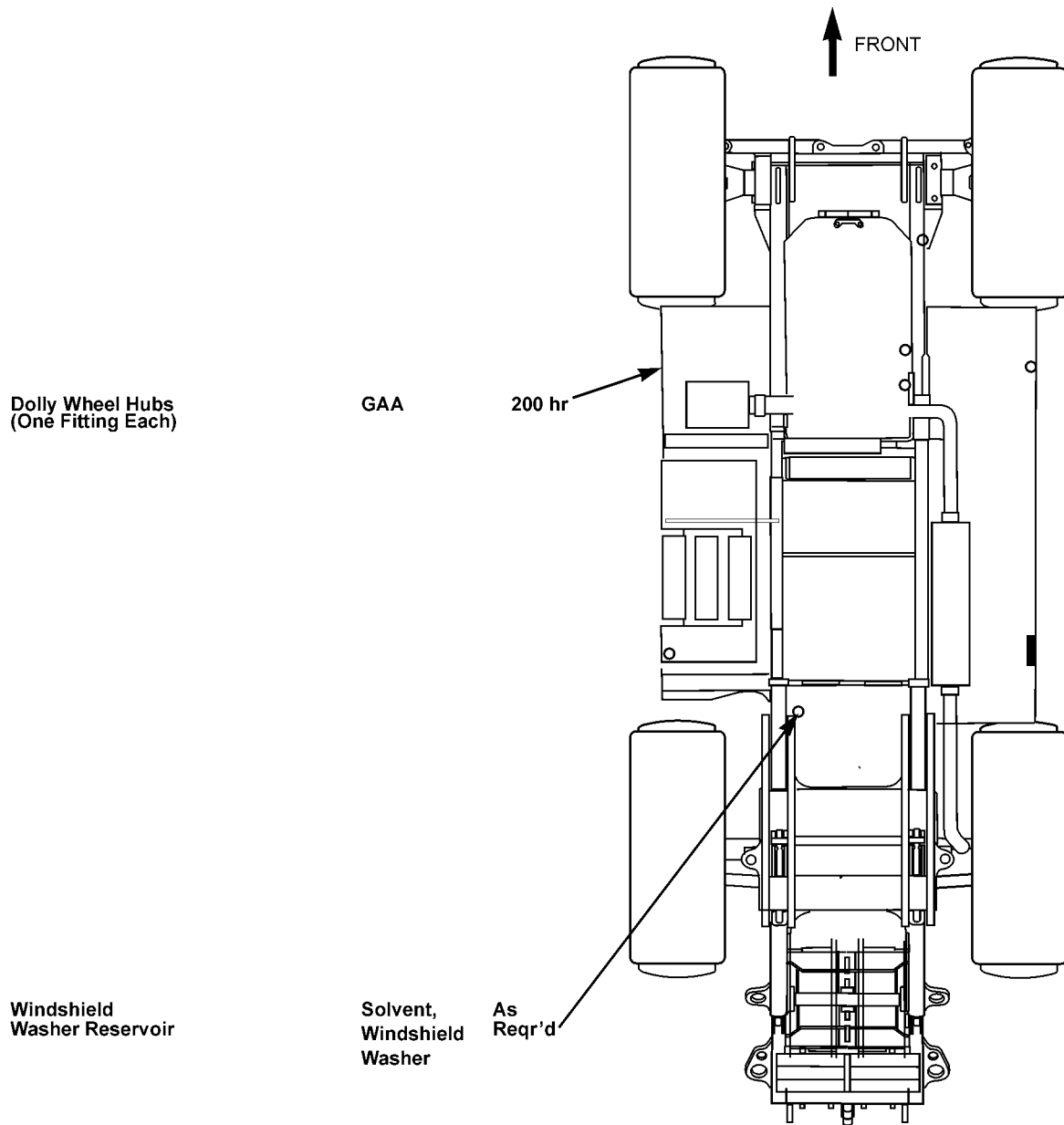

USMC or units with serial numbers ending .0400 or above

LUBRICANT • INTERVAL

Tophandler
Pivot Pins
One Fitting Each

GAA 300 hr



Front Axle Steering
Cylinder
Two Fittings

GAA AUTO LUBE

Front Propeller Shaft
and Universal Joints
Three Fittings

GAA 300 hr

Cab Door Hinge Pin
Two Fittings

GAA 900 hr

Boom Support
Locking Pins
(Note 3)

GAA 300 hr

Boom Support
Pivot Pins
One Fitting Each

GAA AUTO LUBE

Lifting Boom
Pivot Pins
(One Fitting Each)

GAA AUTO LUBE

Bogie Wheel Cylinder
Four Fittings

GAA 900 hr

Bogie Wheel Frame
One Fitting

GAA 900 hr

Bogie Wheel Axle
One Fitting Each Side

GAA 900 hr

Pintle Hook
Two Fittings

GAA 900 hr

Dashed lines indicate lubrication points on BOTH sides of vehicle.

NOTE

DO NOT lubricate boom and tophandler wear plates.

434-20013

USMC or units with serial numbers ending .0400 or above

LUBRICANT • INTERVAL

Chain Wheel
One Fitting Each Side

GAA 300 hr

Front Axle Steering
Knuckle Pin
Two Upper Fittings,
One Lower Fitting

GAA AUTO LUBE

Front Axle U-Joint
Two Fittings

GAA 300 hr

Rear Propeller Shaft
and Universal Joints
Three Fittings

GAA 300 hr

Rear Axle Pivot
Bearing
Two Fittings

GAA AUTO LUBE

Rear Axle Knuckle Pin
Two Upper Fittings
One Lower Fitting

GAA AUTO LUBE

Rear Axle U-joint
Two Fittings

GAA 300 hr

Rear Axle Steering
Cylinder
Two Fittings

GAA AUTO LUBE

Boom Folding Cylinders
Two Fittings Each Side

GAA AUTO LUBE

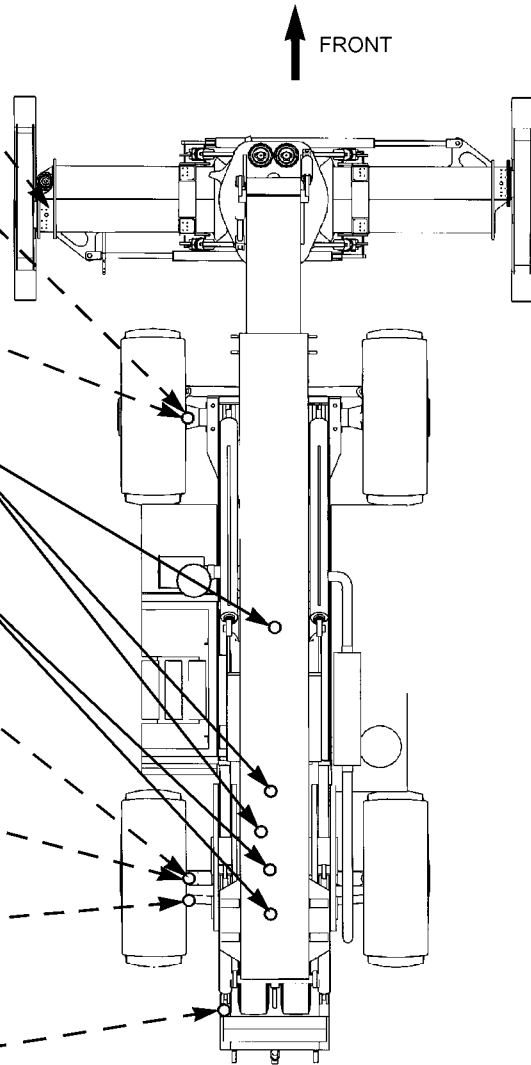

Dashed lines indicate lubrication points on BOTH sides of vehicle.

NOTE

DO NOT lubricate boom and tophandler wear plates.

434-20014

GENERAL LUBRICATION PROCEDURES - CONTINUED**Note 1:**

Drain fuel/water separator weekly. Dispose of drained fluid IAW local policy.

Note 2:

In order to properly check the transmission oil level, the following steps **MUST** be followed:

- a. Park the RTCH on level ground.
- b. Set parking brake.
- c. Place the transmission selector in neutral "N" position.
- d. Start engine and idle until operating temperature is reached.
- e. Remove transmission oil dipstick, clean, and reinstall.
- f. Remove and check transmission oil level at least two times. Correct transmission oil level should be within two indicator marks at end of dipstick.
- g. If level is low, add transmission oil as follows: Add oil through transmission oil fill opening until level on dipstick is within two indicator marks end of dipstick.

NOTE

- **With transmission at operating temperature, the transmission oil level **MUST NOT** exceed the upper indicator mark. If the oil level is above this mark, notify Organizational Maintenance.**
- **With transmission at operating temperature, if transmission oil level is below the lower indicator mark, transmission oil level **MUST** be increased to be between indicator marks.**

Note 3:

Every 300 hours, retract locking pins. Cover pins with a thin coat of Grease, Automotive and Artillery GAA (Item 7, WP 0019 00), then extend pins and lock pins into extended position.

END OF WORK PACKAGE

Table 1. Preventive Maintenance Checks and Services (PMCS) for RTCH-RT 240V2.

ITEM NO.	INTERVAL	LOCATION	PROCEDURE	NOT FULLY MISSION CAPABLE IF:
		ITEM TO CHECK/SERVICE		
			NOTE	
			<ul style="list-style-type: none"> • Review all WARNINGS, CAUTIONS, and NOTES before performing PMCS and operating the RTCH-RT 240V2. • Perform all PMCS checks if: <ul style="list-style-type: none"> a. You are the assigned operator but have not operated the machine since the last weekly checks. b. You are operating the RTCH for the first time. • At 100 hours of operation, notify Organizational Maintenance to perform 100-hour initial checks and services. 	
		FRONT AND LEFT SIDE		
1	Before	Overall View	a. Check under RTCH for evidence of fluid leakages such as fuel, oil, coolant, or hydraulic fluid. b. Visually check that tread is visible and for damaged tires. Check for missing or signs of loose lug nuts.	Class III oil, coolant, or hydraulic leaks are evident. Any fuel leaks are evident. No tread is visible, if there are gages below the tread cavity surface depth, there are cuts in sidewall deep enough to expose the steel cord, or there are missing lug nuts.
2	Before	Hydraulic Cylinders	Check hydraulic cylinders behind staircase, hydraulic hoses, lines, and fittings for damage and leaks.	Class III leaks are evident.
3	Before	Remote Hydraulic Control Compartment	a. Open compartment door and visually check hydraulic controls, valves, and lines for signs of leakage. b. Check compartment door, door hinge, and retaining latch for damage.	Class III leaks are evident.
4	Before	Cab Exterior	a. Check for damage to cab door, steps, and handrail. b. Check for damage to cab glass (front, top, sides, and rear), windshield wiper blades, and arms. c. Check for damage to the rear of cab, windshield washer reservoir, horn, air conditioning system components, and hydraulic lines and cylinders.	Damage that would interfere with visibility or impair safe operation is evident. Class III leaks are evident.

Table 1. Preventive Maintenance Checks and Services (PMCS) for RTCH-RT 240V2 - Continued.

ITEM NO.	INTERVAL	LOCATION	PROCEDURE	NOT FULLY MISSION CAPABLE IF:
		ITEM TO CHECK/SERVICE		
5	Before	Boom Support Locking Pin	Ensure both boom support locking pins are present and extensions are locked by retaining pins in extended position.	Boom support locking pins are missing, extensions are not locked in extended position or are damaged.
<div style="display: flex; justify-content: space-around;"> <div style="text-align: center;"> <p>BOOM SUPPORT LOCKING PIN</p>  <p>BOOM SUPPORT LOCKING PIN EXTENSION</p> </div> <div style="text-align: center;"> <p>BOOM SUPPORT RETAINING PIN</p>  <p>BOOM SUPPORT LOCKING PIN EXTENSION (RETRACTED)</p> <p><small>374M-0014</small></p> </div> </div>				
6	Before	<p style="text-align: center;">REAR AND RIGHT SIDE</p> <p>Overall View</p>	<p>a. Check under RTCH for evidence of fluid leakages such as oil, coolant, or hydraulic fluid.</p> <p>b. Visually check that tread is visible and for damaged tires. Check for missing or signs of loose lug nuts.</p>	<p>Class III oil, coolant, or hydraulic leaks are found. Any fuel leaks are found.</p> <p>No tread is visible, there are gages below the tread cavity surface depth, there are cuts in sidewall deep enough to expose the steel cord, or there are missing lug nuts.</p>
7	Before	Hydraulic Cylinders	Check all hydraulic cylinders, hoses, lines, and fittings for damage and leaks.	Class III oil leaks are evident.
8	Before	Boom Support Locking Pin	Ensure boom support locking pin is present and extension is locked in extended position on both sides.	Boom support locking pins are missing, extension is not locked in extended position, or are damaged.

Table 1. Preventive Maintenance Checks and Services (PMCS) for RTCH-RT 240V2 - Continued.

ITEM NO.	INTERVAL	LOCATION	PROCEDURE	NOT FULLY MISSION CAPABLE IF:
		ITEM TO CHECK/SERVICE		
9	Before	Hydraulic Reservoir and Sight Gage	<p>a. Check for damage and leaks.</p> <p style="text-align: center;">NOTE</p> <p>Boom must be fully lowered and retracted and RTCH parked on level ground before checking hydraulic oil level in reservoir. Engine should be stopped at least five minutes.</p> <p>b. If level is low, before adding oil, remove one of the fill plugs from the oil filter cover plates at the top of the hydraulic oil tank and allow the RTCH to rest another five minutes. Recheck the oil level. If level is still low, add oil only through one of the fill points. Refer to add oil IAW instructions in WP 0012 00.</p> <p>c. Check hydraulic oil in oil level sight gage. If hydraulic oil is visible in sight gage, level is okay. If level is low, add oil IAW instructions in WP 0012 00.</p>	<p>Class III leaks are evident.</p> <p>Hydraulic oil level is below sight gage.</p>

Table 1. Preventive Maintenance Checks and Services (PMCS) for RTCH-RT 240V2 - Continued.

ITEM NO.	INTERVAL	LOCATION	PROCEDURE	NOT FULLY MISSION CAPABLE IF:
		ITEM TO CHECK/SERVICE		
		LIFTING BOOM AND TOP-HANDLER		
10	Before	Boom Hydraulics	Check all hydraulic cylinders, hoses, lines, and fittings for damage and leaks.	Class III leaks are evident.
11	Before	Boom Lights	Check all light assemblies for damage or missing parts.	a. Damage to lights that would impair night operation. b. Twistlock indicator lights are damaged.
12	Before	Tophandler Hydraulics	Check all hydraulic cylinders, hoses, lines, and fittings for damage and leaks.	Class III leaks are evident.
13	Before	Tophandler Lights	Check all light assemblies for damage or missing parts.	Damage to work lights that would impair night operation.
14	Before	Twistlocks	Visually check all twistlocks, hydraulic cylinders, electrical wiring, and switches for signs of damage.	a. Damage that would impair operation is evident. b. Class III leaks are evident.

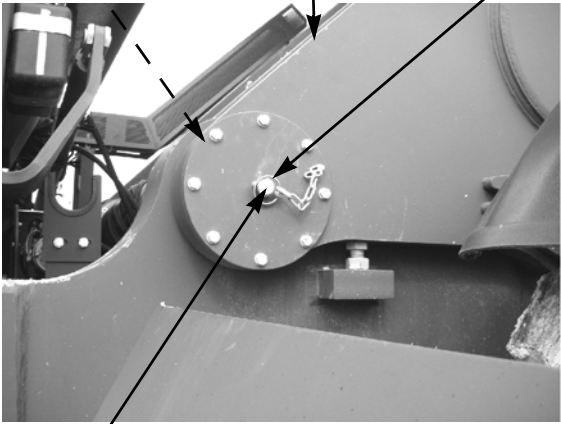
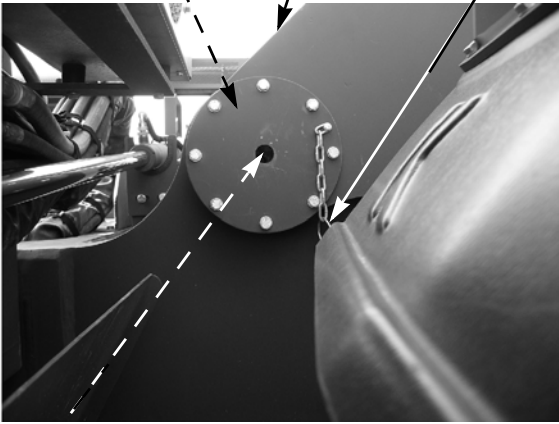
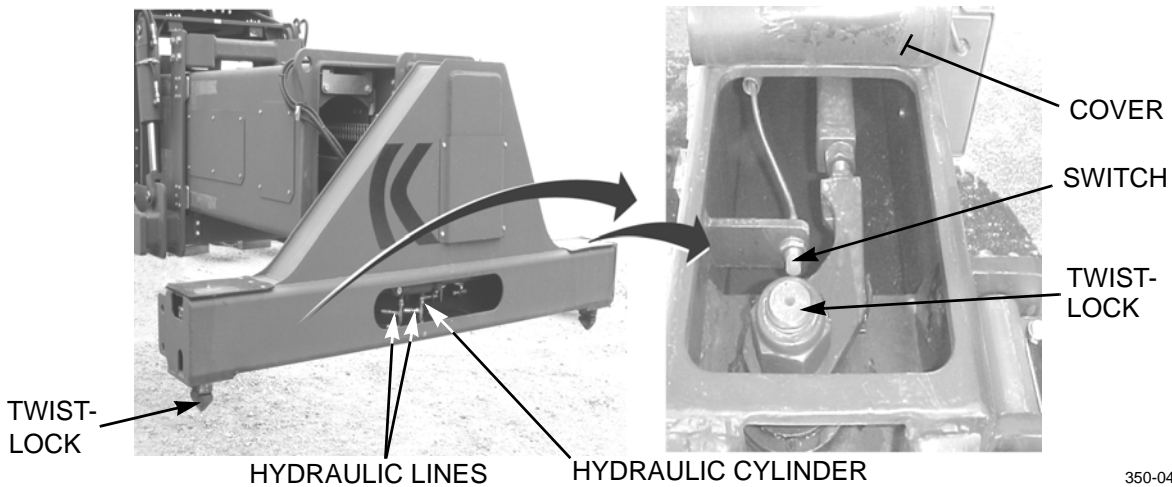

350-044

Table 1. Preventive Maintenance Checks and Services (PMCS) for RTCH-RT 240V2 - Continued.

ITEM NO.	INTERVAL	LOCATION	PROCEDURE	NOT FULLY MISSION CAPABLE IF:
		ITEM TO CHECK/SERVICE		
15	Before	Engine Oil Level	NOTE	
			<p>To ensure an accurate reading, RTCH must be parked on level ground.</p> <p>Check engine oil level on dipstick. Maintain oil level with indicator marks between LOW and HIGH. If level is low, add oil IAW instructions in WP 0012 00.</p>	
				
				
16	Before	Battery Storage Compartment	Open battery storage compartment and visually check batteries, battery cables, slave receptacles, solar charger (if equipped), and master battery switch for damage.	Damage or missing parts that would impair operation is evident.
NOTE				
Perform the following checks if forklift kit is to be used.				
17	Before	Forklift Kit	<p>a. Ensure all retaining and locking pins are present and properly secured.</p> <p>b. Inspect hydraulic hoses and quick-disconnects for dirt, damage, and proper operation.</p>	<p>Retaining or locking pins are missing.</p> <p>Hydraulic hoses or quick-disconnects are damaged.</p>

Table 1. Preventive Maintenance Checks and Services (PMCS) for RTCH-RT 240V2 - Continued.

ITEM NO.	INTERVAL	LOCATION	PROCEDURE	NOT FULLY MISSION CAPABLE IF:
		ITEM TO CHECK/SERVICE		
		CAB INTERIOR		
			NOTE Refer to WP 0004 00 for the location of all gages, switches, and indicator lights.	
18	Before	Instrument Panel	Check for damaged gages, switches, indicators, and warning lights.	Any warning indicator is broken or unreadable.
19	Before	Fire Extinguisher	a. Check for missing or damaged fire extinguisher. b. Check gage for proper pressure reading. c. Check for damaged or missing seal.	Fire extinguisher is missing or damaged. Pressure gage needle is in recharge area. Seal is broken or missing.
20	Before	Seat and Seat Belt	Check seat and seat belt for damage and proper operation.	Seat belt is damaged.
21	Before	Steering Wheel and Column	Check steering wheel and column for damage and proper operation (tilt and height adjustments).	
22	During	Engine Startup	a. Start engine. Verify that all indicator and warning lights operate properly on ECS display screen. b. Check air cleaner restriction indicator. If red band is showing, service air cleaner (WP 0014 00). c. Check operating lights (brake lights, turn signals, etc.).	Engine will not start. Warning lights remain ON. Red band is showing. Brake lights and turn signals do not operate.
23	During	Hydraulic Controls	a. Perform a functional check of all boom lifting and tophandler operations. b. Ensure red twistlock indicator light at end of boom is lit.	Any system or function is not operating properly. Twistlock indicator light is not lit.

Table 1. Preventive Maintenance Checks and Services (PMCS) for RTCH-RT 240V2 - Continued.

ITEM NO.	INTERVAL	LOCATION	PROCEDURE	NOT FULLY MISSION CAPABLE IF:
		ITEM TO CHECK/SERVICE		
24	During	Instrument Panel	<p>a. With RTCH fully warmed up, monitor indicators and warning lights on ECS display screen. Check that engine oil pressure and temperature, transmission, hydraulic, and coolant temperatures register within normal ranges:</p> <ul style="list-style-type: none"> • Engine oil pressure—15 to 35 psi (103 to 241 kPa) at idle • Transmission temperature—175° to 220°F (79° to 104°C) • Hydraulic oil temperature—below 160°F (71°C) • Coolant temperature—175° to 210°F (79 to 99°C) <p>b. Ensure alternator charging lamp is not lit.</p> <p>c. Monitor all boom lifting and tophandler functions on the ECS display screens.</p>	<p>ECS display screen indicates an abnormal reading.</p> <p>Alternator charging lamp remains lit.</p> <p>Loss of ECS display functions occurs.</p>
25	During	Brakes	Check service brakes for pulling, grabbing, or reduced braking ability.	<p>a. Brakes pull, grab, or exhibit unsafe operation.</p> <p>b. Parking brake will not hold RTCH.</p>
26	During	Steering	Check for smooth, controlled steering without pulling or drifting. Check 2-wheel, 4-wheel, and crab steering modes.	Steering is erratic or will not change modes of operation.
27	During	Drive Train	Check for unusual noise or vibration from engine, transmission, drive shafts, axles, and wheels.	
28	During	Overall Leakage	Be alert for evidence of fluid leakage.	Class III oil, coolant, or hydraulic leaks are evident. Any fuel leaks are evident.

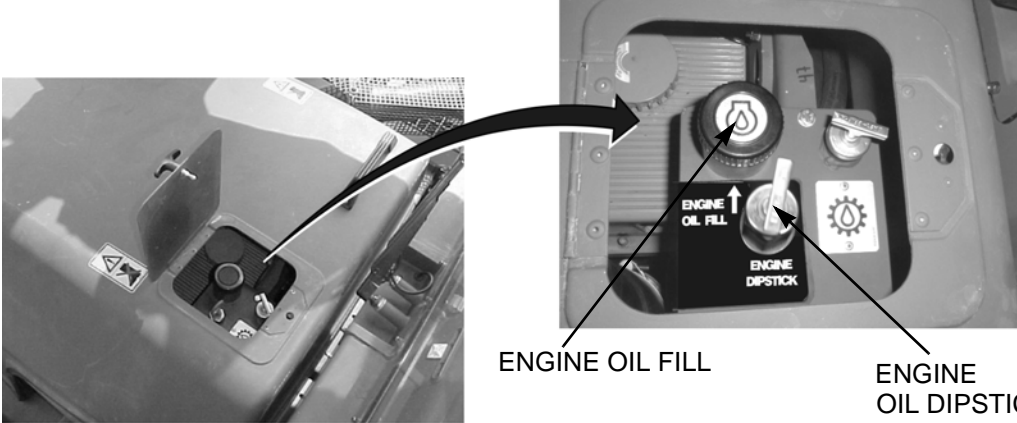
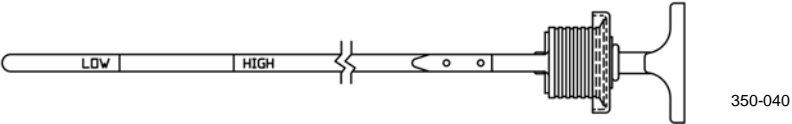
Table 1. Preventive Maintenance Checks and Services (PMCS) for RTCH-RT 240V2 - Continued.

ITEM NO.	INTERVAL	LOCATION	PROCEDURE	NOT FULLY MISSION CAPABLE IF:
		ITEM TO CHECK/SERVICE		
29	After	FRONT AND LEFT SIDE		
		Overall View	a. Check under RTCH for evidence of fluid leakages such as oil, coolant, or hydraulic fluid. b. Visually check that tread is visible and for damaged tires. Check for missing or signs of loose lug nuts.	Class III oil, coolant, or hydraulic leaks are evident. Any fuel leaks are evident. No tread is visible, there are gauges below the tread cavity surface depth, there are cuts in sidewall deep enough to expose the steel cord, or there are missing lug nuts.
30	After	Left-Front Fender and Lights	a. Check fender and mirror for damage or missing parts. b. Check all light assemblies for damage.	Damage to lights that would impair their operation is evident.
31	After	Battery Storage Compartment	a. Open battery storage compartment door and visually check batteries, battery cables, slave receptacles, solar charger, and master battery switch for damage. b. Check storage compartment door, door hinge, and retaining latch for damage.	Damage or missing part that would impair operation is evident.
32	After	REAR AND RIGHT SIDE		
		Overall View	a. Check under RTCH for evidence of fluid leakages such as oil, coolant, or hydraulic fluid. b. Visually check for damaged tires. Check for missing or signs of loose lug nuts.	Class III oil, coolant, or hydraulic leaks are evident. Any fuel leaks are evident. A tire with major damage that would impair operation is found or lug nuts are missing.

Table 1. Preventive Maintenance Checks and Services (PMCS) for RTCH-RT 240V2 - Continued.

ITEM NO.	INTERVAL	LOCATION	PROCEDURE	NOT FULLY MISSION CAPABLE IF:
		ITEM TO CHECK/SERVICE		
33	After	Rear Fenders, Lights, and Backup Alarm	a. Check rear fenders for damage or missing parts. b. Check all light assemblies and backup alarm for damage.	Lights or backup alarm are damaged. Class III leaks are evident.
34	After	Folding Step and Ladder	Check for damage or missing parts.	
35	After	Hydraulic Reservoir and Sight Gage	a. Check for damage and leaks. <p style="text-align: center;">NOTE</p> <p>Boom must be fully lowered and retracted and RTCH parked on level ground before checking hydraulic oil level in reservoir. Engine should be stopped at least five minutes.</p> b. Check hydraulic oil in the oil level sight gage. If hydraulic oil is visible in sight gage, level is okay. If level is low, before adding oil, remove one of the fill plugs from the oil filter cover plates at the top of the hydraulic oil tank and allow the RTCH to rest another five minutes. Recheck the oil level. If level is still low, add oil only through one of the fill points. Refer to add oil IAW instructions in WP 0012 00.	

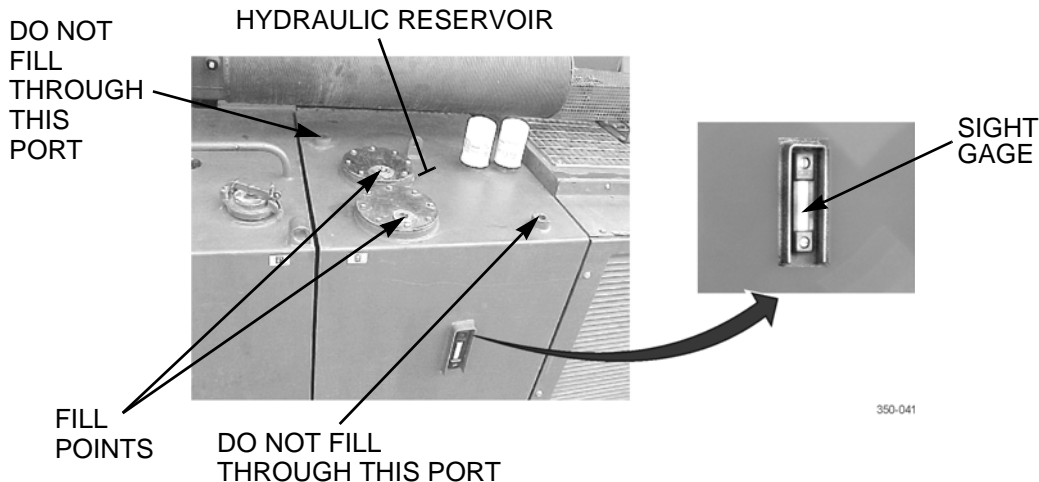

Table 1. Preventive Maintenance Checks and Services (PMCS) for RTCH-RT 240V2 - Continued.

ITEM NO.	INTERVAL	LOCATION	PROCEDURE	NOT FULLY MISSION CAPABLE IF:
		ITEM TO CHECK/SERVICE		
36	After	Fuel Tank and Filler Cap	 <p>WARNING</p> <p>DO NOT perform fuel system checks, inspections, or maintenance while smoking or near fire, flames, or sparks. Fuel may ignite, causing damage to machine and injury or death to personnel.</p> <p>Check fuel tank, filler cap, and cap seal for damage or leakage.</p>	Any damage or leakage is evident.
				

Table 1. Preventive Maintenance Checks and Services (PMCS) for RTCH-RT 240V2 - Continued.





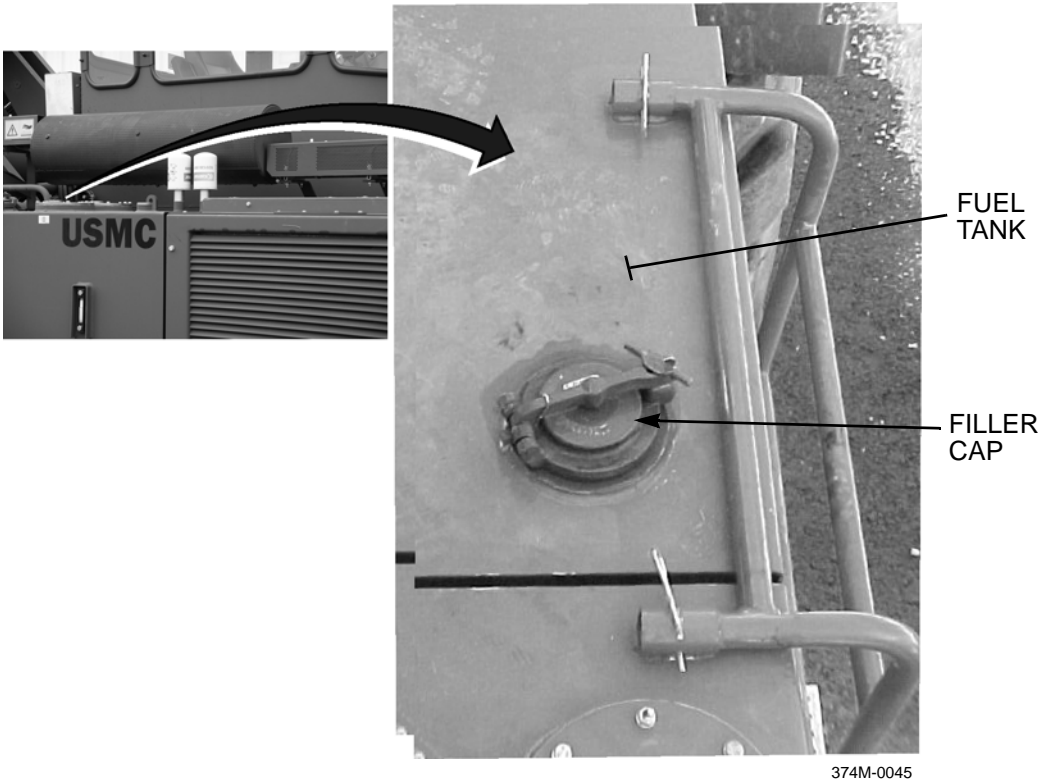

ITEM NO.	INTERVAL	LOCATION	PROCEDURE	NOT FULLY MISSION CAPABLE IF:
		ITEM TO CHECK/SERVICE		
37	After	Cooling System	 <p style="text-align: center;">WARNING</p>  <ul style="list-style-type: none"> • DO NOT service cooling system unless engine has been allowed to cool down. DO NOT remove radiator cap. Add coolant only to expansion tank. This is a pressurized cooling system and escaping steam or hot coolant will cause serious burns. • Wear effective eye, glove, and skin protection when handling coolants. Failure to do so may cause injury. <p>a. Visually check radiator for leaks, damage, or obstructions. Remove any obstructions.</p> <p>b. Check coolant level in expansion tank. Level should be between the MIN and MAX lines on tank. Add coolant as required.</p>	Class III leaks are evident.
			 <p style="text-align: right;">MAX</p> <p style="text-align: right;">MIN</p> <p style="text-align: right; font-size: small;">374M-0041</p>	

Table 1. Preventive Maintenance Checks and Services (PMCS) for RTCH-RT 240V2 - Continued.

ITEM NO.	INTERVAL	LOCATION	PROCEDURE	NOT FULLY MISSION CAPABLE IF:
		ITEM TO CHECK/SERVICE		
38	After	Right-Front Fender and Lights	a. Check fender and mirror for damage or missing parts. b. Check all light assemblies for damage and proper operation.	Lights are damaged.
39	After	Transmission Oil Level	With engine idling, transmission selector lever in N, parking brake set, and engine at operating temperature [coolant temperature of 180°F (82°C) minimum], remove transmission dipstick. Level as indicated on dipstick should be maintained within two indicator marks at end of dipstick. If level is low, add transmission fluid IAW instructions in WP 0012 00.	

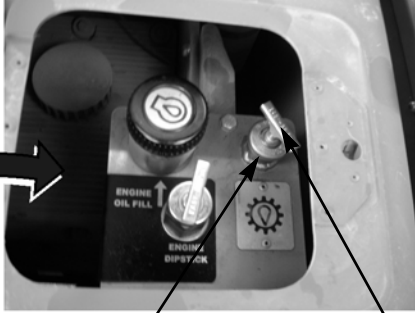

374M-0022

Table 1. Preventive Maintenance Checks and Services (PMCS) for RTCH-RT 240V2 - Continued.

ITEM NO.	INTERVAL	LOCATION	PROCEDURE	NOT FULLY MISSION CAPABLE IF:
		ITEM TO CHECK/SERVICE		
40	After	Engine Oil Level	<p>NOTE</p> <p>To ensure an accurate reading, machine must be parked on level ground. Wait 10 minutes after shutting down engine to allow oil to drain into crankcase.</p> <p>Check engine oil level on dipstick. Maintain oil level between HIGH and LOW marks at end of dipstick. If level is low, add oil IAW instructions in WP 0012 00.</p>	
				
41	After	LIFTING BOOM AND TOP-HANDLER		
		Boom Hydraulics	<p>a. Check hydraulic cylinders for damage and leaks.</p> <p>b. Check hydraulic hoses, lines, and fittings for damage and leaks.</p>	<p>Class III leaks are evident.</p> <p>Class III leaks are evident.</p>

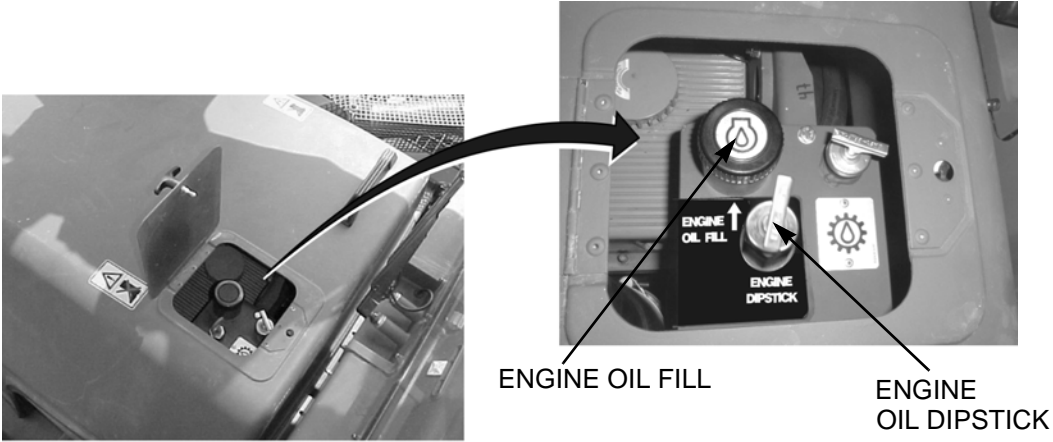
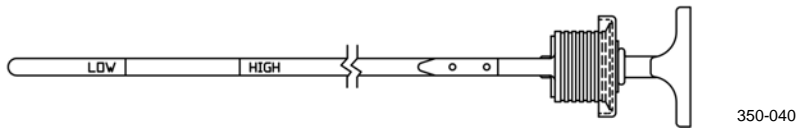

Table 1. Preventive Maintenance Checks and Services (PMCS) for RTCH-RT 240V2 - Continued.

ITEM NO.	INTERVAL	LOCATION	PROCEDURE	NOT FULLY MISSION CAPABLE IF:
		ITEM TO CHECK/SERVICE		
42	After	Boom Lights	Check all light assemblies for damage or missing parts.	Damage to lights that would impair night operation is evident. Twistlock indicator lights are damaged.
43	After	Tophandler Hydraulics	a. Check hydraulic cylinders for damage and leaks. b. Check hydraulic hoses, lines, and fittings for damage and leaks.	Class III leaks are evident. Class III leaks are evident.
44	After	Tophandler Lights	Check all light assemblies for damage or missing parts.	Damage to work lights that would impair night operation is evident.
45	After	Twistlocks	Visually check all twistlocks, hydraulic cylinders, electrical wiring, and switches for signs of damage.	a. Damage that would impair operation is evident. b. Class III leaks are evident.

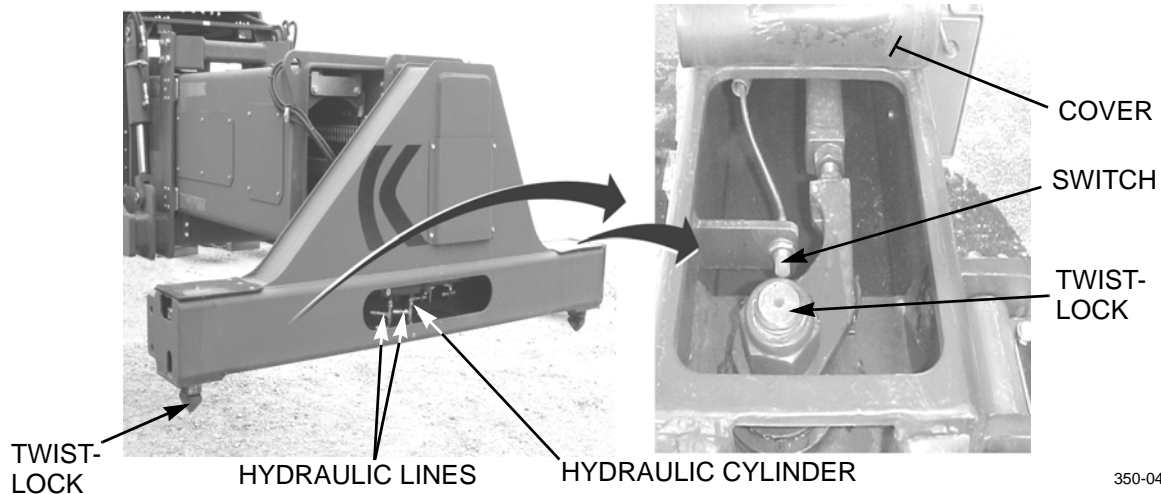

Table 1. Preventive Maintenance Checks and Services (PMCS) for RTCH-RT 240V2 - Continued.



ITEM NO.	INTERVAL	LOCATION	PROCEDURE	NOT FULLY MISSION CAPABLE IF:
		ITEM TO CHECK/SERVICE		
46	After	Forklift Kit	<p style="text-align: center;">NOTE</p> <p style="text-align: center;">Perform the following checks if forklift kit was used.</p> <p>a. Check for damage or leaks to lines, fittings, and hydraulic cylinders.</p> <p>b. Check for cracks or other damage to forks.</p> <p>c. Inspect fork positioning shaft for dirt or damage.</p>	Class III leaks are evident.
47	Weekly	Air Cleaner Assembly	<div style="display: flex; justify-content: center; align-items: center;">  WARNING  </div> <p>If NBC exposure is suspected, all air cleaner media should be handled by personnel wearing protective equipment. Consult your NBC officer or NBC NCO for appropriate handling or disposal procedures.</p> <p>Check filter restriction indicator located at rear outlet of air cleaner. If indicator shows 22 in. of vacuum, service air cleaner (WP 0014 00).</p>	

Table 1. Preventive Maintenance Checks and Services (PMCS) for RTCH-RT 240V2 - Continued.



ITEM NO.	INTERVAL	LOCATION	PROCEDURE	NOT FULLY MISSION CAPABLE IF:
		ITEM TO CHECK/SERVICE		
48	Weekly	Drive Belts	a. Check for loose, missing, broken, frayed, or cracked alternator belt. b. Check for loose, missing, broken, frayed, or cracked air conditioner drive belts.	Belt is loose or damaged. Belts are loose or damaged.
<div style="display: flex; justify-content: space-around; margin-bottom: 5px;"> ALTERNATOR AND WATER PUMP DRIVE BELT AIR CONDITIONER DRIVE BELTS </div>  <p style="text-align: right; font-size: small; margin-right: 100px;">350-047</p>				
49	Weekly	Fuel/Water Separator	<div style="text-align: center; margin-bottom: 10px;">  <p>WARNING</p> <p>DO NOT perform fuel system checks, inspections, or maintenance while smoking or near fire, flames, or sparks. Fuel may ignite, causing damage to machine and injury or death to personnel.</p> <p>NOTE</p> <p>Ensure that a suitable container is used to catch draining fluid.</p> </div> a. Turn drain knob counterclockwise and drain all water from fuel/water separator. b. Turn knob clockwise to close.	

Table 1. Preventive Maintenance Checks and Services (PMCS) for RTCH-RT 240V2 - Continued.

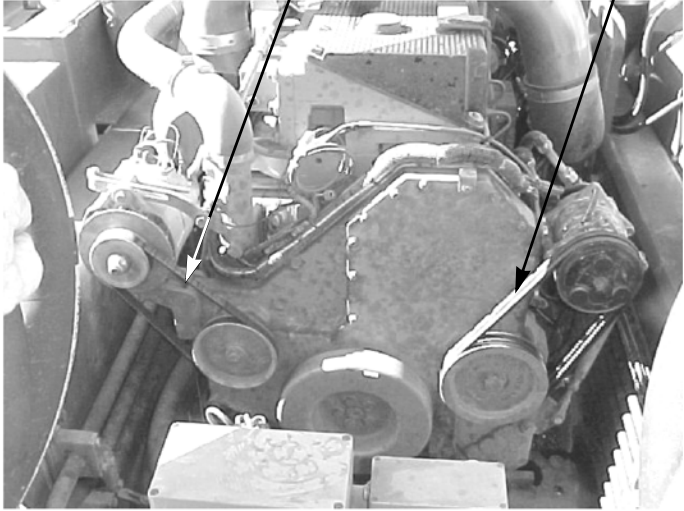

ITEM NO.	INTERVAL	LOCATION	PROCEDURE	NOT FULLY MISSION CAPABLE IF:
		ITEM TO CHECK/SERVICE		
49 (Con't)	Weekly	Fuel/Water Separator	 <p style="text-align: right;">FUEL/WATER SEPARATOR</p> <p style="text-align: right;">DRAIN KNOB</p> <p style="text-align: right; font-size: small;">350-046</p>	
50	Weekly	Ether Quick-Start System	 <p>WARNING</p> <p>Ether is highly flammable and explosive. DO NOT perform ether quick-start system checks or inspections while smoking or near fire, flame, or sparks. Failure to follow this warning may cause a fire or explosion, causing serious injury or death to personnel.</p> <p>Check for loose connections and damage to lines, fittings, and canister. Be alert for odor of leaking ether.</p>	<p>Damage is noted or canister is missing.</p>

Table 1. Preventive Maintenance Checks and Services (PMCS) for RTCH-RT 240V2 - Continued.

ITEM NO.	INTERVAL	LOCATION	PROCEDURE	NOT FULLY MISSION CAPABLE IF:
		ITEM TO CHECK/SERVICE		
51	Weekly	Batteries (USMC)	 <p>WARNING</p> <p>To avoid eye injury, eye protection is required when working around batteries. DO NOT smoke, use open flame, make sparks, or create other ignition sources around batteries. If a battery is giving off gases, it can explode and cause injury to personnel. Remove all jewelry, such as rings, ID tags, watches, and bracelets. If jewelry or a tool contacts a battery terminal, a direct short will result in instant heating, damage to equipment, and injury to personnel.</p> <p>CAUTION</p> <p>To reduce battery damage, do not remove batteries from machine battery compartment unless the compartment is corroded (greenish/white powder). DO NOT jerk or pull on battery cables during visual inspection. Battery replacement will be performed by Organizational Maintenance.</p>	<p>a. Remove four remaining pins and battery compartment cover carefully so as not to damage solar panel electrical connection. Check battery compartment for damaged or missing batteries.</p> <p>b. Check for missing, broken, split, or frayed cables.</p>

Damage is noted.

Battery cables are damaged.

Table 1. Preventive Maintenance Checks and Services (PMCS) for RTCH-RT 240V2 - Continued.

ITEM NO.	INTERVAL	LOCATION	PROCEDURE	NOT FULLY MISSION CAPABLE IF:
		ITEM TO CHECK/SERVICE		
51 (Con't)	Weekly	Batteries (USMC)	c. Check for damaged terminal posts. d. Check for rust, corrosion, and cleanliness.	Damage is noted.
52	Weekly	Batteries (RESET)	a. Remove battery compartment cover. Check battery compartment for damaged or missing batteries. b. Check for damaged or missing battery filler cap. c. Check level of distilled water in battery cells. Fluid level should be to bottom of split ring. d. Check for missing, broken, split, or frayed cables. e. Check for damaged terminal posts. f. Check for rust, corrosion, and cleanliness.	Damage noted. Damage is noted. Fluid level is low. Battery cables are damaged. Damaged is noted.

Table 1. Preventive Maintenance Checks and Services (PMCS) for RTCH-RT 240V2 - Continued.

ITEM NO.	INTERVAL	LOCATION	PROCEDURE	NOT FULLY MISSION CAPABLE IF:
		ITEM TO CHECK/SERVICE		
53	Weekly	Wheels and Tires	<p align="center">WARNING</p> <p align="center">Operating the RTCH with an underinflated or defective tire may lead to tire failure and loss of steering control. Damage to equipment or injury to personnel may result.</p> <p align="center">NOTE</p> <p align="center">If tire pressure is below 30 psi (207 kPa), DO NOT inflate. Notify Organizational Maintenance.</p>	
54	Weekly	Dolly Wheel Storage Compartment	<p>a. Check pressure in tires and adjust as required to 85 psi (586 kPa).</p> <p>b. Check if all wheel lug nuts are tight.</p> <p>Check dolly wheel storage compartment doors, door hinges, and retaining latch for damage.</p>	<p>If tire pressure is below 30 psi (207 kPa).</p> <p>Lug nuts are loose.</p>
55	Weekly	Dolly and Bogie Wheels	<p>a. Check for presence and general condition of four air transport dolly wheels in dolly wheel storage compartment. Ensure dolly wheel tires are inflated to 85 psi (586 kPa).</p> <p>b. Lower and visually check bogie wheels and tires for damage. Ensure tires are inflated to 85 psi (586 kPa).</p>	<p>Dolly wheels are missing or damaged, if required for air transport.</p> <p>Damage that would impair operation is evident, if required for air transport.</p>
56	Weekly	Cab	Check operation and general condition of doors, windows, and storage compartments.	
57	Weekly	Exhaust System	Check exhaust system for corrosion, looseness, or damage.	Exhaust system damage is noted.
58	Weekly	Air Conditioner	Check air conditioner operation. Operate for at least five minutes to help prevent drying and cracking of tubing seals and reduce refrigerant leaks in the system.	
59	Weekly	Boom Lifting Pin Stub Shaft	Check for cracks around weld of boom lifting pin stub shaft.	Cracks exceed 2 in. (50.8 mm).

Table 1. Preventive Maintenance Checks and Services (PMCS) for RTCH-RT 240V2 - Continued.

ITEM NO.	INTERVAL	LOCATION	PROCEDURE	NOT FULLY MISSION CAPABLE IF:
		ITEM TO CHECK/SERVICE		
60	Weekly	Slave Receptacles	Check for damage to NATO slave receptacle on each side of vehicle.	
61	Weekly	Tophandler Hydraulics	Check oil level of oil in upper and lower sight gages on tophandler hydraulic slewing motors and sight gage of tophandler hydraulic spreader motor (WP 0012 00).	Hydraulic oil is not visible in sight gage(s).
62	Monthly	IR Lights	<p style="text-align: center;">WARNING</p> <p>DO NOT look directly at IR lights without night vision goggles. Injury to personnel may result.</p> <p>a. Use night vision goggles to check operation of all machine IR lights.</p> <p>b. A circle of blue-green dots will be visible when looking through night vision goggles.</p>	Vehicle IR lights not operational.

Table 1. Preventive Maintenance Checks and Services (PMCS) for RTCH-RT 240V2 - Continued.

ITEM NO.	INTERVAL	LOCATION	PROCEDURE	NOT FULLY MISSION CAPABLE IF:
		ITEM TO CHECK/SERVICE		
63	Monthly	Cab Interior HVAC Filter	 <p>WARNING</p> <p>Particles blown by compressed air are hazardous. Use a maximum of 30 psi (207 kPa) when cleaning components. DO NOT direct compressed air against human skin. Failure to follow this warning may result in injury or death. Make sure air stream is directed away from user and other personnel in the area. To prevent injury, user must wear protective goggles or face shield.</p> <ol style="list-style-type: none"> Remove the thumbscrews from the retaining panel on filter and remove panel and filter. Use clean, low-pressure air to blow contaminants from filter surface. Inspect for damage and replace if any damage is found. Reinstall filter and cover and secure with thumbscrews. 	
				

Table 1. Preventive Maintenance Checks and Services (PMCS) for RTCH-RT 240V2 - Continued.

ITEM NO.	INTERVAL	LOCATION	PROCEDURE	NOT FULLY MISSION CAPABLE IF:
		ITEM TO CHECK/SERVICE		
64	Monthly	Solar Maintenance Charger	a. Clean solar panel to remove dirt, dust, and debris that can reduce solar efficiency. b. Wipe with a soft cloth and water. Do not use cleaning chemicals. c. Check all electrical connections and tighten if necessary. d. When the RTCH is going to be parked for an extended period, orient equipment to obtain maximum sunlight exposure on the solar panel, if possible.	
65	Monthly	Automatic Lubrication System	Visually inspect the grease level in the clear bowl on top of the lubricator system. If the bowl is less than 1/4 full, fill with Grease, Automotive and Artillery GAA (Item 7, WP 0019 00) through the grease fitting located at the base of the bowl. If it appears that the system is not functioning properly, notify Organizational Maintenance.	

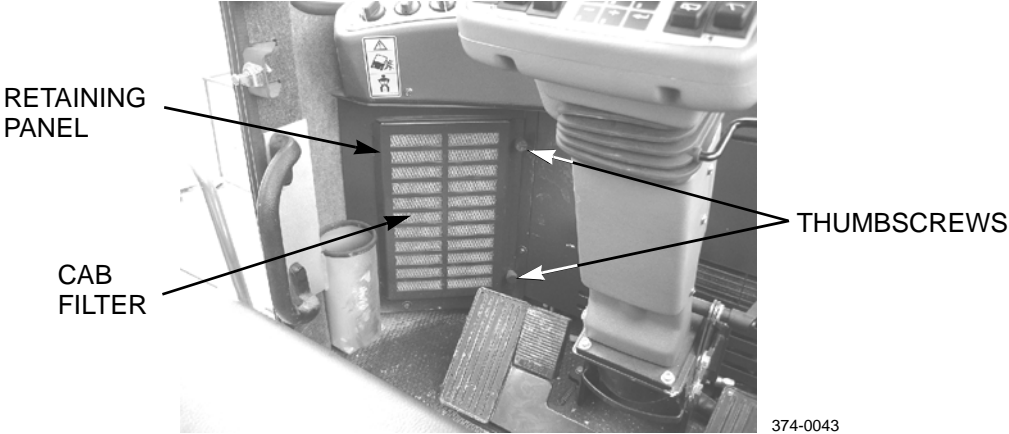
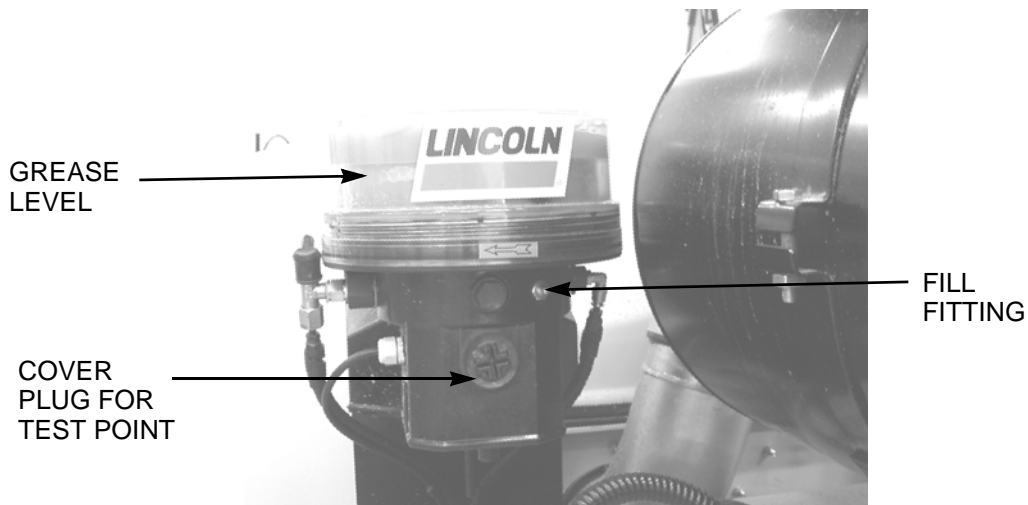

374M-0049

END OF WORK PACKAGE



WARNING



If NBC exposure is suspected, all engine air cleaner air filter media should be handled by personnel wearing protective equipment. Consult your NBC Officer or NBC NCO for appropriate handling or disposal procedures.

NOTE

- Perform service only if indicator shows 22 in. of vacuum.
- Dust vent may be squeezed 2 to 3 times while engine is running to evacuate dust from air cleaner.

1. Wipe exterior of air cleaner assembly clean with a damp Rag, Wiping (Item 12, WP 0019 00).
2. Release six latches and remove cover. Clean inside of cover with a clean, damp rag.

COVER AIR CLEANER ASSEMBLY

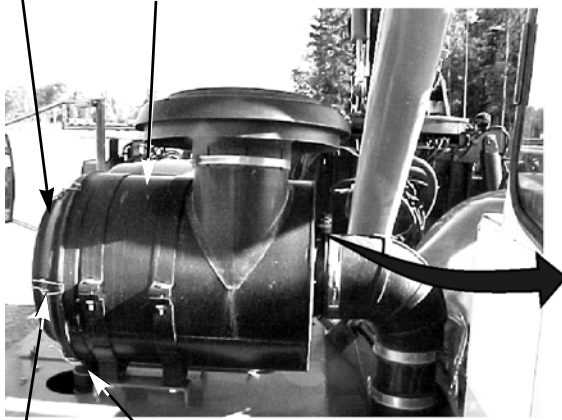

COVER LATCH

DUST VENT



RESTRICTION INDICATOR

374M-0012

3. Remove primary (outer) and secondary (inner) filter elements from housing.

PRIMARY FILTER ELEMENT



SECONDARY FILTER ELEMENT



374M-0044

- Clean inside of housing with a clean, damp rag.

**WARNING**

Compressed air used for cleaning purposes should never exceed 30 psi (207 kPa). Wear protective clothing (goggles/shield, gloves, etc.) and use caution to avoid injury to personnel.

CAUTION

DO NOT pound or strike air cleaner elements against ground or other objects to attempt to knock dirt from filter elements. Serious damage to the elements will result, allowing dirt to enter engine intake systems, causing major engine damage.

- Use compressed air, directed from the inside (clean air side) toward the outside, to remove dust and dirt from primary and secondary filter elements.
- After cleaning with compressed air, inspect primary and secondary filter elements for tears or other damage. Replace with new filter elements, if damaged.
- Install secondary filter element and seat inside housing. Install primary filter element.
- Install cover on housing and secure with six latches.
- Reset air cleaner restriction indicator.

END OF WORK PACKAGE



WARNING



- **DO NOT** smoke or permit any open flame in area of RTCH while you are servicing diesel fuel system. Be sure hose nozzle is grounded against filler tube during refueling to prevent static electricity. Failure to follow this warning may result in injury to personnel or equipment damage.
 - Operating personnel must wear fuel-resistant gloves when handling fuels. If exposed to fuel, promptly wash exposed skin and change fuel-soaked clothing.
 - Place portable fire extinguisher within reach prior to refueling.
 - **DO NOT** overfill tank. If fuel starts foaming from fuel tank, stop immediately to avoid fuel spillage.
 - Failure to follow these warnings could result in injury or death to personnel.
1. Shut down engine.
 2. Wipe off dirt on and around filler cap.
 3. Unlatch filler cap and open.
 4. Refuel tank. Level of fuel should come approximately half-way up filter screen. **DO NOT** overfill tank.
 5. Close filler cap and latch.

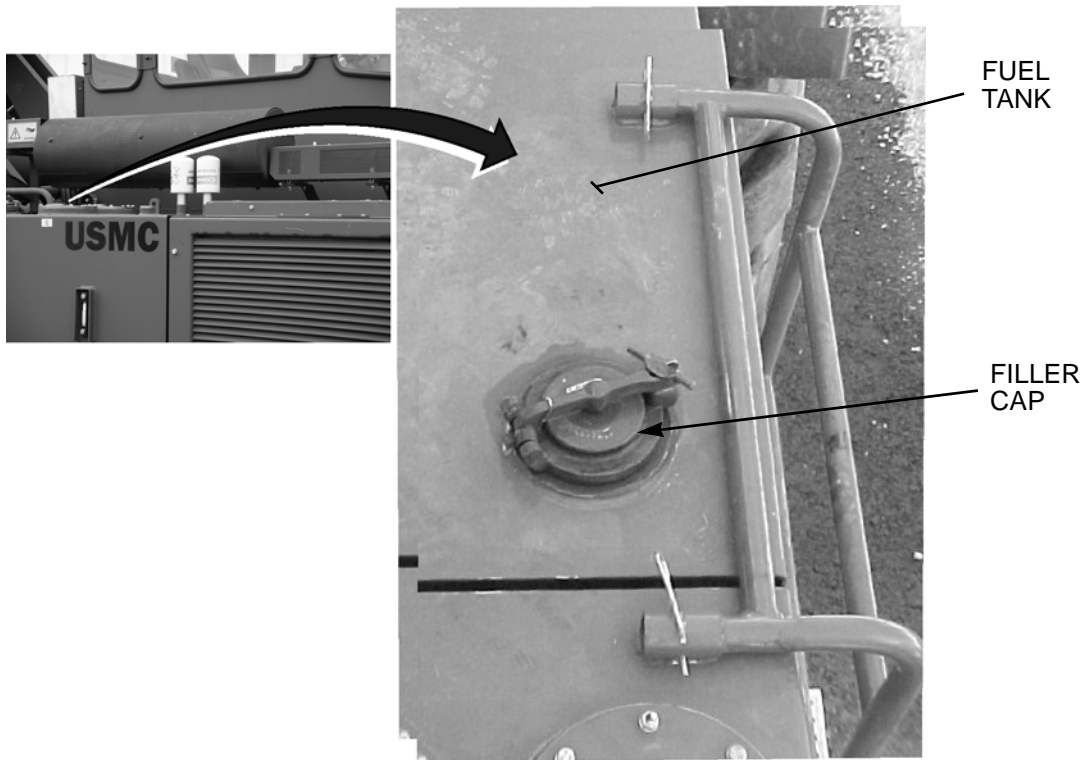

END OF WORK PACKAGE

CHAPTER 5
SUPPORTING INFORMATION

REFERENCES

0016 00

SCOPE

This work package lists all forms, field manuals, technical manuals, and other publications referenced in this manual and which apply to the operation of the RTCH-RT 240V2.

PUBLICATION INDEX

The following index should be consulted frequently for latest changes or revisions and for new publications relating to material covered in this technical manual.

Marine Corps Publications Distribution System (MCPDS) <https://pubs.ala.usmc.mil/front.htm>

FORMS

Limited Technical Inspection NAVMC 10560
 Product Quality Deficiency Report SF Form 368
 Recommended Changes to Publications/Logistics Maintenance Data Coding Sheet. NAVMC 10772

FIELD MANUALS

Basic Cold Weather Manual FM 31-70
 Camouflage FM 5-20
 Cold Weather Operations FM 9-207
 Desert Operations FM 90-3
 Driver Selection/Training FM 21-300
 First Aid. FM 4-25.11
 Manual for the Wheeled Vehicle Driver FM 21-305
 NBC Contamination Avoidance FM 3-3
 NBC Decontamination FM 3-5
 NBC Protection FM 3-4
 Northern Operations FM 31-71
 Vehicle Recovery Operations FM 20-22

TECHNICAL MANUALS

Care, Maintenance, Repair, and Inspection of Pneumatic Tires and Inner Tubes. TM 9-2610-200-14
 Operator's, Unit, Direct, and General Support Maintenance Manual for
 Trailers, M1000 HET TM 9-2330-381-14
 Rough Terrain Container Handler (RTCH) RT 240V2; 53,000 lb capacity; 4x4 TM 11078A-OR

TECHNICAL BULLETINS

Supply Instructions SI 11078A-OI

OTHER PUBLICATIONS

Abbreviations and Acronyms ASME Y14.38-1999
 Transportability Criteria MIL-STD-1366D
 Joint Oil Analysis Program (JOAP) MCO 4731.1A

END OF WORK PACKAGE

SCOPE

This work package lists COEI and BII for the RTCH-RT 240V2 to help you inventory items required for safe and efficient operation.

GENERAL

The COEI and BII information is divided into the following lists:

1. **Table 1, Components of End Item List.** This listing is for informational purposes only and is not authority to requisition replacements. These items are part of the end item, but are removed and separately packaged for transportation or shipment. As part of the end item, these items must be with the end item whenever it is issued or transferred between property accounts. Illustrations are furnished to assist you in identifying the items.
2. **Table 2, Basic Issue Items List.** These are the minimum essential items required to place the RTCH in operation, to operate it, and to perform emergency repairs. Although shipped separately packaged, BII must be with the RTCH during operation and whenever it is transferred between property accounts. This manual is your authority to request/requisition replacement BII, based on TOE/MTOE authorization of end item. Illustrations are furnished to assist you in identifying the items.

EXPLANATION OF COLUMNS

Below is an explanation of columns found in the tabular listings:

1. **Column (1) - Illustration Number (Illus Number).** This column indicates the number of the illustration that shows the item.
2. **Column (2) - National Stock Number.** Indicates the National Stock Number (NSN) assigned to the item and used for requisitioning purposes.
3. **Column (3) - Description, CAGEC, and Part Number.** Indicates the Federal item name (in all capital letters) and, if required, a minimum description in parentheses to identify and locate the item. The entry for each item ends with the Commercial and Government Entity Code (CAGEC) in parentheses followed by the part number.
4. **Column (4) - Usable on Code.** Indicates a code if the item needed is not the same for different models of equipment. Usable on Code is not applicable to the RTCH-RT 240V2.
5. **Column (5) - Unit of Issue (U/I).** Indicates how the item is issued for the National Stock Number (NSN) shown in Column (2).
6. **Column (6) - Quantity Required (Qty Rqd).** Indicates the quantity of the item required.

Table 1. Components of End Item List.

There are currently no COEI assigned.

Table 2. Basic Issue Items List.

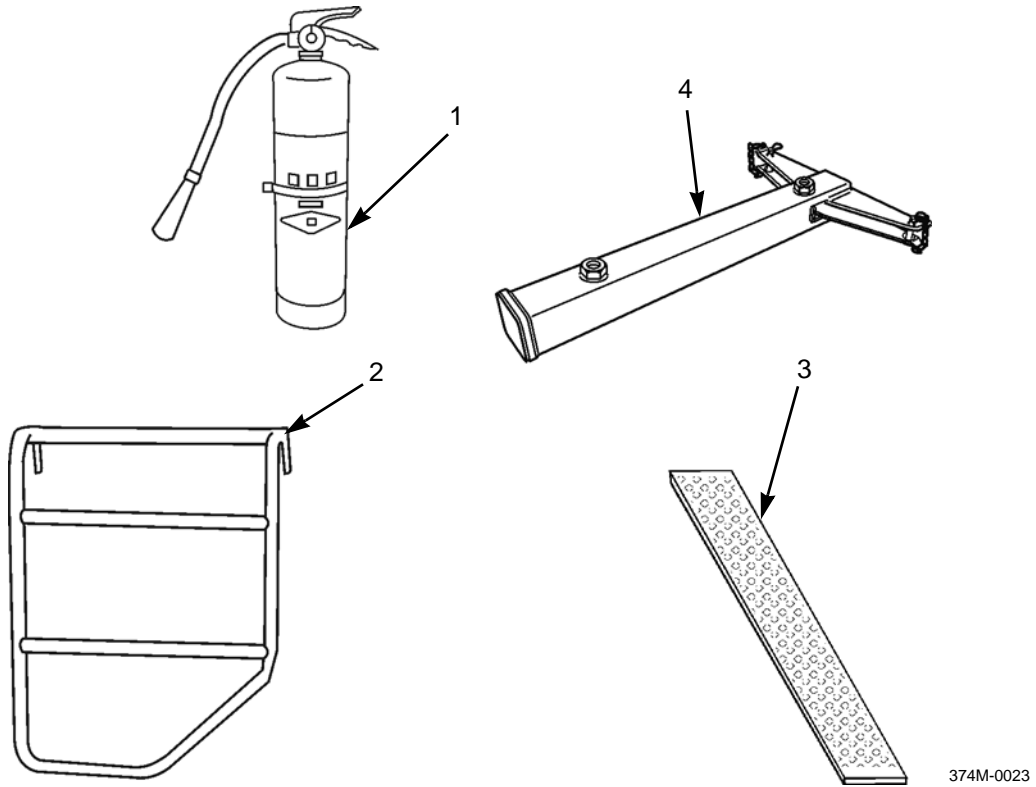

(1) Illus Number	(2) National Stock Number	(3) Description, CAGEC, and Part Number	(4) Usable on Code	(5) U/I	(6) Qty Rqd
1	4210-01-485-9754	EXTINGUISHER, FIRE (1NWX2) 12J1057		EA	1
2	2590-01-478-4688	LADDER/HANDRAIL (1NWX2) A36453.0100		EA	1
3	5340-01-480-3124	RAMP, DOLLY WHEELS (1NWX2) A36296.0100		EA	1
4	2510-01-540-4046	BOOM REST, TRANSPORT A42654.0100		EA	1

Table 2. Basic Issue Items List - Continued.

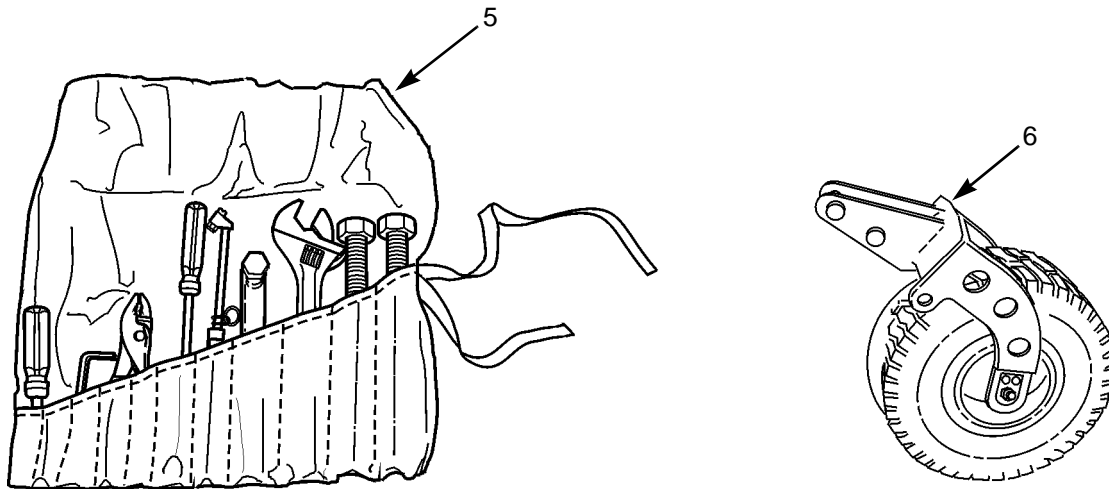

434-10008

(1) Illus Number	(2) National Stock Number	(3) Description, CAGEC, and Part Number	(4) Usable on Code	(5) U/I	(6) Qty Rqd
5	5180-01-487-3162	TOOL KIT: (1NWX2) 12J1035			
	4910-00-204-3170	• Gage, Tire Pressure: 10 to 160 psi (27783) 7188BH		EA	1
	5120-00-224-4659	• Key, Socket Head, 1/4 in. (74445) 57026		EA	1
	5120-00-223-7397	• Pliers, Slip Joint (56161) 10510983		EA	1
	5140-01-491-0562	• Pouch, Tool (1NWX2) 12J1068		EA	2
	5120-01-487-5688	• Screw, Jacking (1NWX2) 12J1029		EA	1
	5210-00-240-8716	• Screwdriver, Cross Tip (80204) B107.15TY2DEASZ1		EA	1
	5120-00-237-6985	• Screwdriver, Flat Tip (56161) 10510988		EA	1
	5120-01-487-5686	• Tool, Hydraulic Reservoir (1NWXZ) 12J1028		EA	1
	5120-00-264-3796	• Wrench, Adjustable (96508) D712		EA	1
6	2530-01-480-3549	WHEEL, DOLLY (1NWX2) A38709.0100		EA	4

END OF WORK PACKAGE

SCOPE

This work package lists additional items that are authorized to you for the support of the RTCH-RT 240V2.

GENERAL

This list identifies items that do not need to accompany the RTCH and that do not need to be turned in with it.

EXPLANATION OF COLUMNS

1. **Column (1) - National Stock Number.** Indicates the National Stock Number (NSN) assigned to the item and used for requisitioning purposes.
2. **Column (2) - Description, CAGEC, and Part Number.** Indicates the Federal item name (in all capital letters) followed by a minimum description when needed. The entry for each item ends with the Commercial and Government Entity Code (CAGEC) in parentheses followed by the part number.
3. **Column (3) - Usable on Code.** Indicates a code if the item needed is not the same for different models of equipment. Usable on Code is not applicable to the RTCH-RT 240V2.
4. **Column (4) - Unit of Issue (U/I).** Indicates how the item is issued for the National Stock Number (NSN) shown in Column (1).
5. **Column (5) - Qty RECM.** Indicates the quantity recommended.

Table 1. Additional Authorization List.

(1) National Stock Number	(2) Description, CAGEC, and Part Number	(3) Usable on Code	(4) U/I	(5) Qty RECM
3930-01-479-1624	KIT, FORKLIFT A36522.0100 (1NWX2)		EA	1

END OF WORK PACKAGE

EXPENDABLE AND DURABLE ITEMS LIST

0019 00**SCOPE**

This work package lists expendable and durable items you will need to operate and maintain the RTCH-RT 240V2. This listing is for informational purposes only and is not authority to requisition the listed items. These items are authorized to you by CTA 50-970, *Expendable/Durable Items (Except Medical, Class V Repair Parts, and Heraldic Items)*, or CTA 8-100, *Army Medical Department Expendable/Durable Items*.

EXPLANATION OF COLUMNS

1. **Column (1) - Item Number.** This number is assigned to the entry in the listing and is referenced in the narrative instructions to identify the item [e.g., Use Antifreeze, Permanent Ethylene Glycol, Inhibited, Heavy-Duty (Item 1, WP 0019 00)].
2. **Column (2) - Level.** This column identifies the lowest level of maintenance that requires the listed item.
C - Operator/Crew
3. **Column (3) - National Stock Number.** This is the National Stock Number (NSN) assigned to the item which you can use to requisition it.
4. **Column (4) - Description, CAGEC, and Part Number.** This provides the other information you need to identify the item.
5. **Column (5) - Unit of Measure (U/M).** This column shows the physical measurement or count of an item, such as gal., dozen, gross, etc.

Table 1. Expendable and Durable Items List.

(1) ITEM NUMBER	(2) LEVEL	(3) NATIONAL STOCK NUMBER	(4) DESCRIPTION, CAGEC, AND PART NUMBER	(5) U/M
1	C	6850-01-181-7929	Antifreeze, Permanent Ethylene Glycol, Inhibited, Heavy-Duty (81349) MILA46153 1 Gallon Can	GAL.
		6850-00-181-7933	5 Gallon Container	GAL.
2	C	6850-00-926-2275	Cleaning Compound, Windshield (81348), O-C-1901	PT
3	C	7930-00-282-9699	Detergent, General Purpose, Liquid (81348) P-D-220	GAL
			1 Gallon Can	
4	C	9140-00-286-5295 9140-00-286-5296	Fuel Diesel, DF-2 Grade (81348) VVF800GRADEDF2RE	GAL. GAL.
			5 Gallon Can 55 Gallon Drum, 16 Gage	
5	C	9140-00-286-5287 9140-00-286-5288	Fuel, Diesel, Winter (81348) VVF800GRADEDF1W1	GAL. GAL.
			5 Gallon Can 55 Gallon Drum, 16 Gage	
6	C	9130-01-031-5816	Fuel, Turbine, Aviation (81349) MILT83133 GR JP8	GAL.
7	C	9150-01-197-7688 9150-01-197-7693 9150-01-197-7690 9150-01-197-7609 9150-01-197-7692	Grease, Automotive and Artillery GAA (81349) MIL-G-10924	OZ OZ LB LB LB
			1-1/4 Ounce Tube	
			14 Ounce Cartridge	
			2-1/4 Pound Can	
			6-1/2 Pound Can	
8	C	9150-01-048-4591 9150-01-035-5395 9150-01-035-5396	Oil, Lubricating GO 85W/140 (81349) MIL-L-2105	QT GAL. GAL.
			1 Quart Can	
			5 Gallon Can	
			55 Gallon Drum	

Table 1. Expendable and Durable Items List - Continued.

(1) ITEM NUMBER	(2) LEVEL	(3) NATIONAL STOCK NUMBER	(4) DESCRIPTION, CAGEC, AND PART NUMBER	(5) U/M
9	C	9150-00-402-4478 9150-00-402-2372 9150-00-491-7197	Oil, Lubricating, Arctic, OEA (81349) MIL-L-46167 1 Quart Can 5 Gallon Can 55 Gallon Drum	QT GAL. GAL.
10	C	9150-00-189-6727 9150-00-186-6668 9150-00-191-2772	Oil, Lubricating, OE/HDO 10 (81349) MIL-L-2104 1 Quart Can 5 Gallon Can 55 Gallon Drum	QT GAL. GAL.
11	C	9150-01-152-4117 9150-01-152-4118 9150-01-152-4119	Oil, Lubricating, OE/HDO 15W/40 (81349) MIL-L-2104 1 Quart Can 5 Gallon Can 55 Gallon Drum	QT GAL. GAL.
12	C	7920-00-205-1711	Rag, Wiping (64067) 7920-00-205-1711 50 Pound Bale	LB
13	C	6650-01-377-1808 6850-01-331-3349 6850-01-331-3350	Solvent, Dry Cleaning, Type III (81348) P-D-680 1 Quart Can 5 Gallon Can 55 Gallon Drum	QT GAL. GAL.

END OF WORK PACKAGE

ERROR CODE TABLE

1. Table 4 in this work package identifies error codes resident on the RTCH on-board computer. These error codes are visible to both the driver and the maintainer and address very specific equipment conditions on the vehicle.
2. This error code listing also addresses required *driver actions* based on the category and type of error identified.



EXPLANATION OF ERROR CODE DISPLAY

NOTE

There are three kinds of information in the Electronic Control System (ECS) display.





1. Icons in the *lower left corner* of the display describe what the driver should do. Table 1 defines each of the three driver actions.

Table 1. Driver Action Icons.

ICON	DESCRIPTION
	STOP VEHICLE IMMEDIATELY in a safe way. This can be a safety issue. Vehicle performance may be restricted. Read operator's manual for instructions. Some stop codes will shut engine down in 30 to 45 seconds. Some stop codes will restrict engine speed to 1,000 to 1,400 RPM. Contact maintenance personnel.
	WARNING - DEGRADED OPERATION, stop vehicle in a safe way. Read operator's manual for instructions. Contact maintenance personnel. Confirm that error message is acknowledged by pressing RESET button. Error will appear every three minutes as long as error is active. It can be reset every time it shows.
	INFORMATION/MAINTENANCE action is needed. Error code shows once when vehicle starts up. Acknowledge error message by pressing RESET. These error codes may be deactivated for driver, so that they only show when maintenance personnel activate them.

2. Icons in the *center* of the display identify the type of fault. Table 2 describes the five fault types used in the display.





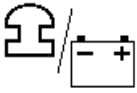





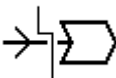

Table 2. Type of Fault Icons.

ICON	DESCRIPTION	ICON	DESCRIPTION
	Sensor		Lever
	Valve		Temperature
	Pressure		

EXPLANATION OF ERROR CODE DISPLAY - CONTINUED

3. Icons in the *right* of the display identify what function or vehicle system the fault is related to. Table 3 lists the various functions or vehicle systems used in the display.

Table 3. Function Icons.

ICON	DESCRIPTON	ICON	DESCRIPTION
	Battery		Twistlock
	Forklift Kit		Up/Down
	Emergency Stop or Battery		In/Out
	Rotation		Transmission
	Hydraulic Filter		Fan
	Communication		Engine

EXPLANATION OF ERROR CODE DISPLAY - CONTINUED

Table 3. Function Icons - Continued.







ICON	DESCRIPTON	ICON	DESCRIPTION
	Sideshifting		No Overload Protection
	Oscillation (leveling)		Brake
	Spreading		Tilt
	Steering		

Table 4. Error Codes.

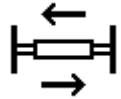
ERROR CODE	DISPLAY LAYOUT	DRIVER ACTION	ERROR CODE CATEGORY/ EXPLANATION	VEHICLE LIMITATIONS
103		Stop Vehicle	Stop Vehicle Immediately Error code appears during ECU replacement.	Operating system not responding.
105		Stop Vehicle Put load down safely. Abort mission. Notify maintenance.	Stop Vehicle Immediately ECU 790 not responding. Circuit breaker tripped. Cable defective. ECU 790 defective.	Operating system not responding. Boom and tophandler may not work. Reduced power and engine speed.
106		Stop Vehicle Put load down safely. Abort mission. Notify maintenance.	Stop Vehicle Immediately ECU 791 not responding. Circuit breaker tripped. Cable defective. ECU 791 defective.	Operating system not responding. Boom and tophandler may not work. Reduced power and engine speed.
107		Press RESET Finish mission. Notify maintenance.	Information/Maintenance Communication, cable segment 1 between ECU 795 and 791. Cable between ECU 795 and 791 interrupted or short circuited.	No redundancy in ECS system for boom, display, and tophandler functions.
108		Press RESET Finish mission. Notify maintenance.	Information/Maintenance Communication, cable segment 2 between ECU 791 and 790. Cable between ECU 791 and 790 interrupted or short circuited.	No redundancy in ECS system for boom, display, and tophandler functions.
109		Press RESET Finish mission. Notify maintenance.	Information/Maintenance Communication, cable segment 3 between ECU 790 and 795. Cable between ECU 790 and 795 interrupted or short circuited.	No redundancy in ECS system for boom, display, and tophandler functions.
110		Stop Vehicle Abort mission. Notify maintenance.	Stop Vehicle Immediately Communication, ECU 792 - steering computer not responding. Circuit breaker tripped. Cable defective. ECU 792 defective.	Steering may not function properly. Reduced power and engine speed.

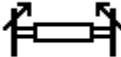
Table 4. Error Codes - Continued.

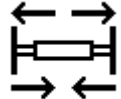

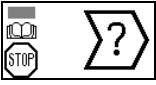
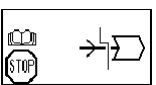
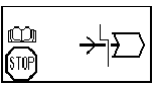
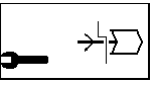
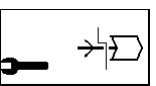
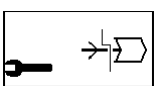
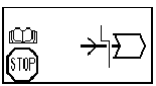

ERROR CODE	DISPLAY LAYOUT	DRIVER ACTION	ERROR CODE CATEGORY/ EXPLANATION	VEHICLE LIMITATIONS
111		Stop Vehicle Abort mission. Notify maintenance.	Stop Vehicle Immediately Communication, ECU 793 - transmission computer not responding. Circuit breaker tripped. Cable defective. ECU 793 defective.	Transmission may not function properly. Reduced power and engine speed.
112		Stop Vehicle Abort mission. Notify maintenance.	Stop Vehicle Immediately ECU 794 - Engine computer not responding. Circuit breaker tripped. Cable defective. ECU 794 defective.	Engine may not function properly. Reduced power and engine speed.
118		Stop Vehicle Put load down safely. Abort mission. Notify maintenance.	Stop Vehicle Immediately No pressure/signal - both brake circuits. Circuit breaker tripped. Hydraulic failure.	Brakes may not function properly. Reduced power and engine speed.
119		Stop Vehicle Press RESET. Finish mission. Notify maintenance.	Warning - Degraded Operation No pressure - brake circuit 1. Hydraulic failure.	Only half brake capability available.
120		Stop Vehicle Press RESET. Finish mission. Notify maintenance.	Warning - Degraded Operation No pressure - brake circuit 2. Hydraulic failure.	Only half brake capability available.
121		Stop Vehicle Put load down safely. Abort mission. Notify maintenance.	Stop Vehicle Immediately Supply voltage - ECU 790. Emergency stop engaged. Circuit breaker tripped. Cable defective.	Operating system and boom function not working. Reduced power and engine speed.
122		Stop Vehicle Put load down safely. Abort mission. Notify maintenance.	Stop Vehicle Immediately Supply voltage - CAN 790. Circuit breaker tripped. Cable defective.	Operating system and boom function not working. Reduced power and engine speed.

Table 4. Error Codes - Continued.

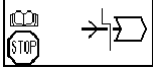
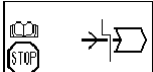

ERROR CODE	DISPLAY LAYOUT	DRIVER ACTION	ERROR CODE CATEGORY/ EXPLANATION	VEHICLE LIMITATIONS
123		Stop Vehicle Put load down safely. Abort mission. Notify maintenance.	Stop Vehicle Immediately Ref. voltages 10V - ECU 790. Circuit breaker tripped. Cable defective.	Operating system and boom function not working. Reduced power and engine speed.
125		Stop Vehicle Shut engine off/on. If code clears, resume mission. If code remains, notify maintenance.	Stop Vehicle Immediately Memory fault ECU790 - software mismatching. Circuit breaker tripped. Cable defective.	None if code clears. Operating system and boom function not working. Reduced power and engine speed.
126		Stop Vehicle Put load down safely. Abort mission. Notify maintenance.	Stop Vehicle Immediately Signal for lifting/lowering - out of range. Cable defective. Short circuit. Potentiometer in joystick not functioning.	Lift/lower does not function properly (hydraulic stops). Reduced power and engine speed.
127		Stop Vehicle Put load down safely. Abort mission. Notify maintenance.	Stop Vehicle Immediately Signal for boom in/out - out of range. Cable defective. Short circuit. Potentiometer in joystick not functioning.	Boom in/out does not function properly (hydraulic stops). Reduced power and engine speed.
128		Stop Vehicle Put load down safely. Abort mission. Notify maintenance.	Stop Vehicle Immediately Signal for slewing - out of range. Cable defective. Short circuit. Potentiometer in joystick not functioning.	Slewing does not function properly (hydraulic stops). Reduced power and engine speed.
129		Stop Vehicle Put load down safely. Abort mission. Notify maintenance.	Stop Vehicle Immediately Signal for tilt in/out - out of range. Cable defective. Short circuit. Potentiometer in joystick not functioning.	Tilt does not function properly (hydraulic stops). Reduced power and engine speed.
130		Stop Vehicle Put load down safely. Abort mission. Notify maintenance.	Stop Vehicle Immediately Overload protection error. Error codes 131 and 136 or 210 have been active.	No overload protection system. Reduced hydraulic speed. Reduced power and engine speed.

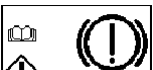
Table 4. Error Codes - Continued.

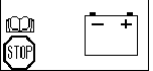
ERROR CODE	DISPLAY LAYOUT	DRIVER ACTION	ERROR CODE CATEGORY/ EXPLANATION	VEHICLE LIMITATIONS
131		Stop Vehicle Press RESET. Put load down safely. Abort mission. Notify maintenance.	Stop Vehicle Immediately Boom sensor - boom length out of range or no signal change when boom is moving. Cable defective. Short circuit. Potentiometer damaged. Hydraulic failure.	No overload protection system. Reduced hydraulic speed. Reduced power and engine speed.
132		Stop Vehicle Press RESET. Put load down safely. Abort mission. Notify maintenance.	Stop Vehicle Immediately Boom sensor - boom angle out of range or no signal change when lowering/lifting boom. Sensor bracket or lever damaged. Cable defective. Short circuit. Potentiometer damaged. Hydraulic failure.	No overload protection system. Reduced hydraulic speed. Reduced power and engine speed.
133		Stop Vehicle Press RESET. Put load down safely. Abort mission. Notify maintenance.	Stop Vehicle Immediately Left lift cylinder pressure sensor - signal out of range. Cable defective. Short circuit. Pressure sensor defective.	No overload protection system. Reduced hydraulic speed. Reduced power and engine speed.
134		Stop Vehicle Press RESET. Put load down safely. Abort mission. Notify maintenance.	Stop Vehicle Immediately Right lift cylinder pressure sensor - signal out of range. Cable defective. Short circuit. Pressure sensor defective.	No overload protection system. Reduced hydraulic speed. Reduced power and engine speed.
135		Stop Vehicle Press RESET. Put load down safely. Abort mission. Notify maintenance.	Stop Vehicle Immediately Left lift cylinder return pressure sensor - signal out of range. Cable defective. Short circuit. Pressure sensor defective.	No overload protection system. Reduced hydraulic speed. Reduced power and engine speed.
136		Stop Vehicle Press RESET. Put load down safely. Abort mission. Notify maintenance.	Stop Vehicle Immediately Right lift cylinder return pressure sensor - signal out of range. Cable defective. Short circuit. Pressure sensor defective.	No overload protection system. Reduced hydraulic speed. Reduced power and engine speed.

Table 4. Error Codes - Continued.

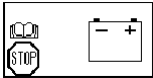
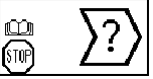
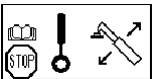
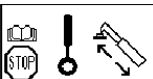
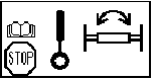
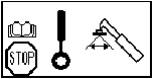
ERROR CODE	DISPLAY LAYOUT	DRIVER ACTION	ERROR CODE CATEGORY/ EXPLANATION	VEHICLE LIMITATIONS
141		Finish Mission Shut engine OFF/ON. If code clears, resume mission. If code remains, notify maintenance.	Information/Maintenance Communication fault - ECU 790. Computer hardware fault.	Possible ECU malfunction. Other codes will also show.
142		Finish Mission Shut engine OFF/ON. If code clears, resume mission. If code remains, notify maintenance.	Information/Maintenance Communication fault - ECU 790. Computer hardware fault.	Possible ECU malfunction. Other codes will also show.
151		Stop Vehicle Put load down safely. Abort mission. Notify maintenance.	Stop Vehicle Immediately Locking valve - broken circuit. Cable to valve defective.	Boom cannot be lowered with joystick. Emergency lowering is necessary. Reduced power and engine speed.
152		Stop Vehicle Put load down safely. Abort mission. Notify maintenance.	Stop Vehicle Immediately Locking valve - short circuit. Cable to valve defective.	Boom cannot be lowered with joystick. Emergency lowering is necessary. Reduced power and engine speed.
154		Stop Vehicle Put load down safely. Abort mission. Notify maintenance.	Stop Vehicle Immediately Lifting valve - broken circuit. Cable to valve defective.	Lifting is impossible. Reduced power and engine speed.
155		Stop Vehicle Put load down safely. Abort mission. Notify maintenance.	Stop Vehicle Immediately Lifting valve - short circuit. Cable to valve defective.	Uncontrolled self-lifting may occur. Reduced power and engine speed.
157		Stop Vehicle Put load down safely. Abort mission. Notify maintenance.	Stop Vehicle Immediately Lowering valve - broken circuit. Cable to valve defective.	Boom cannot be lowered with joystick. Emergency lowering is necessary. Reduced power and engine speed.
158		Stop Vehicle Put load down safely. Abort mission. Notify maintenance.	Stop Vehicle Immediately Lowering valve - short circuit. Cable to valve defective.	Boom cannot be lowered with joystick. Emergency lowering is necessary. Uncontrolled self-lifting may occur. Reduced power and engine speed.

Table 4. Error Codes - Continued.

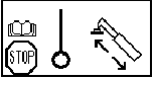
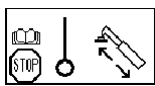
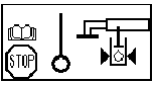
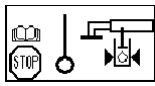
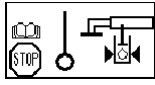
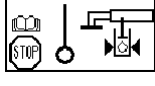

ERROR CODE	DISPLAY LAYOUT	DRIVER ACTION	ERROR CODE EXPLANATION	VEHICLE LIMITATIONS
160		Stop Vehicle Put load down safely. Abort mission. Notify maintenance.	Stop Vehicle Immediately Boom IN valve - broken circuit. Cable to valve defective.	Boom cannot be retracted. Reduced power and engine speed.
161		Stop Vehicle Put load down safely. Abort mission. Notify maintenance.	Stop Vehicle Immediately Boom IN valve - short circuit. Cable to valve defective.	Boom cannot be retracted. Uncontrolled self-retraction may occur. Reduced power and engine speed.
163		Stop Vehicle Put load down safely. Abort mission. Notify maintenance.	Stop Vehicle Immediately Boom OUT valve - broken circuit. Cable to valve defective.	Boom cannot be extended. Reduced power and engine speed.
164		Stop Vehicle Put load down safely. Abort mission. Notify maintenance.	Stop Vehicle Immediately Boom OUT valve - short circuit. Cable to valve defective.	Boom cannot be extended. Uncontrolled self-extension may occur. Reduced power and engine speed.
166		Press RESET Finish mission. Notify maintenance.	Warning - Degraded Operation Cooling fan valve - broken circuit. Cable to valve defective.	Cooling fan will run at full speed. No fording activities possible.
167		Press RESET Finish mission. Notify maintenance.	Warning - Degraded Operation Cooling fan valve - short circuit. Cable to valve defective.	Cooling fan may run at any speed. No fording activities possible. Overheating may occur.
169		Press RESET Finish mission. Notify maintenance.	Warning - Degraded Operation Emergency hydraulic valve - broken circuit. Cable to valve defective.	No hydraulic emergency operation is possible.
172		Press RESET Finish mission. Notify maintenance.	Information/Maintenance Pump turn off valve - broken circuit. Cable defective.	May be difficult to start because of engaged pumps.
191		Stop Vehicle Abort mission. Notify maintenance.	Stop Vehicle Immediately Temperature in front wheel end above 203°F (95°C). Cable defective. No cooling.	Brakes may overheat at front axle. Reduced power and engine speed.

Table 4. Error Codes - Continued.

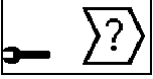
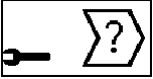
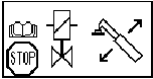
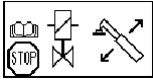
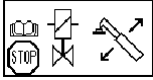
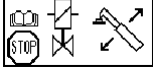
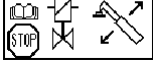
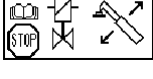

ERROR CODE	DISPLAY LAYOUT	DRIVER ACTION	ERROR CODE EXPLANATION	VEHICLE LIMITATIONS
192		Stop Vehicle Abort mission. Notify maintenance.	Stop Vehicle Immediately Temperature in rear wheel end above 203°F (95°C). Cable defective. No cooling.	Brakes may overheat at rear axle. Reduced power and engine speed.
201		Stop Vehicle Put load down safely. Abort mission. Notify maintenance.	Stop Vehicle Immediately Supply voltage - ECU 791. Emergency stop engaged. Circuit breaker tripped. Cable defective.	Tophandler not working. Reduced power and engine speed.
202		Stop Vehicle Put load down safely. Abort mission. Notify maintenance.	Stop Vehicle Immediately Supply voltage - CAN 791. Circuit breaker tripped. Cable defective.	Operating system and tophandler not working. Reduced power and engine speed.
203		Stop Vehicle Put load down safely. Abort mission. Notify maintenance.	Stop Vehicle Immediately Ref. voltages 10V - 791. Circuit breaker tripped. Cable defective.	Operating system not working. Reduced power and engine speed.
205		Stop Vehicle Shut engine OFF/ON. If code clears, resume mission. If code remains, notify maintenance.	Stop Vehicle Immediately Memory fault ECU 791 - software mismatching. Circuit breaker tripped. Cable defective.	None if code clears. Operating system and tophandler not working. Reduced power and engine speed.
210		Stop Vehicle Press RESET. Put load down safely. Abort mission. Notify maintenance.	Stop Vehicle Immediately Tilt angle sensor - signal out of range. Potentiometer damaged. Cable defective. Short circuit.	Generate error code 130. Reduced power and engine speed.
212		Stop Vehicle Abort mission. Notify maintenance.	Stop Vehicle Immediately Logical error - left twistlock. Short circuit. Signal from both 7204L and 7205L.	Both locked and unlocked twistlock at the same time. Safe operation is not possible. Reduced power and engine speed.
213		Stop Vehicle Abort mission. Notify maintenance.	Stop Vehicle Immediately Logical error - right twistlock. Short circuit. Signal from both 7204R and 7205R.	Both locked and unlocked twistlock at the same time. Safe operation is not possible. Reduced power and engine speed.

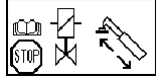
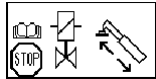
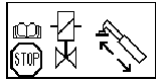
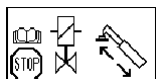
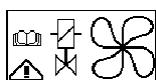
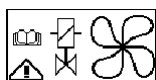
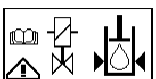
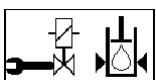
Table 4. Error Codes - Continued.

ERROR CODE	DISPLAY LAYOUT	DRIVER ACTION	ERROR CODE EXPLANATION	VEHICLE LIMITATIONS
214		Stop Vehicle Press RESET. Abort mission. Notify maintenance.	Stop Vehicle Immediately Logical error - forklift sensors. Cable defective. Signal from 7206-1 or 7206-2.	Forklift operation is not possible.
220		Stop Vehicle Press RESET. Finish mission. Notify maintenance.	Warning - Degraded Operation One pulse signal to the steering wheel interrupted. Clock 1. Clock 2. Cables defective. Steering column sensor defective.	Stop vehicle by switching to neutral. Steering system will operate but is not redundant. The steering computer uses uninterrupted signal to steer the vehicle.
221		Finish Mission Shut engine OFF/ON. If code clears, resume mission. If code remains, notify maintenance.	Information/Maintenance Communication fault - ECU 791, connector 2. Computer hardware fault.	Possible ECU malfunction. Other codes will also show.
225		Press RESET Finish mission. Notify maintenance.	Warning - Degraded Operation Left sideshift - open circuit. Cable to valve defective.	Left sideshift is not possible.
226		Press RESET Finish mission. Notify maintenance.	Warning - Degraded Operation Left sideshift - short circuit. Cable to valve defective.	Uncontrolled left sideshift may occur.
228		Press RESET Finish mission. Notify maintenance.	Warning - Degraded Operation Right sideshift - open circuit. Cable to valve defective.	Right sideshift is not possible.
229		Press RESET Finish mission. Notify maintenance.	Warning - Degraded Operation Right sideshift - short circuit. Cable to valve defective.	Uncontrolled right sideshift may occur.
231		Press RESET Finish mission. Notify maintenance.	Warning - Degraded Operation 20 to 40 valve - open circuit. Cable to valve defective.	Spreading from 20 to 40 ft (6.10 to 12.19 m) is not possible.

Table 4. Error Codes - Continued.

ERROR CODE	DISPLAY LAYOUT	DRIVER ACTION	ERROR CODE EXPLANATION	VEHICLE LIMITATIONS
232		Press RESET Finish mission. Notify maintenance.	Warning - Degraded Operation 20 to 40 valve - short circuit. Cable to valve defective.	Spreading from 20 to 40 ft (6.10 to 12.19 m) is not possible.
234		Press RESET Finish mission. Notify maintenance.	Warning - Degraded Operation 20 to 40 valve - open circuit. Cable to valve defective.	Spreading from 20 to 40 ft (6.10 to 12.19 m) is not possible.
235		Press RESET Finish mission. Notify maintenance.	Warning - Degraded Operation 20 to 40 valve - short circuit. Cable to valve defective.	Spreading from 20 to 40 ft (6.10 to 12.19 m) is not possible.
237		Press RESET Finish mission. Notify maintenance.	Warning - Degraded Operation Active tilt valve - open circuit. Cable to valve defective.	Tophandler locked, not automatically leveled.
240		Press RESET Finish mission. Notify maintenance.	Warning - Degraded Operation Active pile slope - open circuit. Cable to valve defective.	Tophandler locked, not free oscillated.
243		Press RESET Finish mission. Notify maintenance.	Warning - Degraded Operation Twistlock valve lock - open circuit. Cable to valve defective.	Impossible to lock twistlock.
246		Press RESET Finish mission. Notify maintenance.	Warning - Degraded Operation Twistlock valve unlock - open circuit. Cable to valve defective.	Impossible to unlock twistlock.

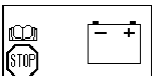
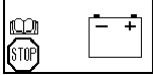
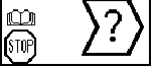
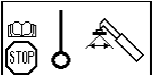
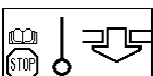
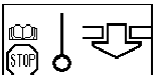
Table 4. Error Codes - Continued.

ERROR CODE	DISPLAY LAYOUT	DRIVER ACTION	ERROR CODE EXPLANATION	VEHICLE LIMITATIONS
250		Finish Mission Shut engine OFF/ON. If code clears, resume mission. If code remains, notify maintenance.	Information/Maintenance Communication fault - ECU 791, connector 3. Computer hardware fault.	Possible ECU malfunction. Other codes will also show.
251		Finish Mission Shut engine OFF/ON. If code clears, resume mission. If code remains, notify maintenance.	Information/Maintenance Communication fault - ECU 791, connector 3. Computer hardware fault.	Possible ECU malfunction. Other codes will also show.
255		Press RESET Finish mission. Notify maintenance.	Warning - Degraded Operation Slewing clockwise valve - open circuit. Cable to valve defective.	Slewing clockwise is not possible.
256		Press RESET Finish mission. Notify maintenance.	Warning - Degraded Operation Slewing clockwise valve - short circuit. Cable to valve defective.	Uncontrolled slewing may occur.
258		Press RESET Finish mission. Notify maintenance.	Warning - Degraded Operation Slewing counterclockwise valve - open circuit. Cable to valve defective.	Slewing counterclockwise is not possible.
259		Press RESET Finish mission. Notify maintenance.	Warning - Degraded Operation Slewing counterclockwise valve - short circuit. Cable to valve defective.	Uncontrolled slewing may occur.
261		Press RESET Finish mission. Notify maintenance.	Warning - Degraded Operation Tilt OUT valve - open circuit. Cable to valve defective.	Tilt OUT is not possible.

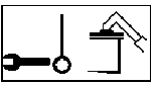
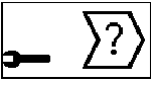
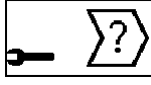
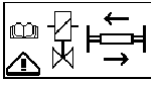
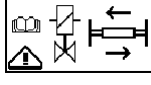
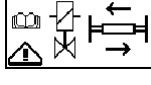
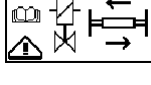
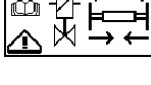
Table 4. Error Codes - Continued.

ERROR CODE	DISPLAY LAYOUT	DRIVER ACTION	ERROR CODE EXPLANATION	VEHICLE LIMITATIONS
262		Press RESET Finish mission. Notify maintenance.	Warning - Degraded Operation Tilt OUT valve - short circuit. Cable to valve defective.	Uncontrolled tilt may occur.
264		Press RESET Finish mission. Notify maintenance.	Warning - Degraded Operation Tilt IN valve - open circuit. Cable to valve defective.	Tilt IN is not possible.
265		Press RESET Finish mission. Notify maintenance.	Warning - Degraded Operation Tilt IN valve - short circuit. Cable to valve defective.	Uncontrolled tilt may occur.
267		Press RESET Finish mission. Notify maintenance.	Warning - Degraded Operation Right oscillation valve - open circuit. Cable to valve defective.	Right oscillation (leveling) is not possible.
268		Press RESET Finish mission. Notify maintenance.	Warning - Degraded Operation Right oscillation valve - short circuit. Cable to valve defective.	Uncontrolled oscillation (leveling) may occur.
270		Press RESET Finish mission. Notify maintenance.	Warning - Degraded Operation Left oscillation valve - open circuit. Cable to valve defective.	Left oscillation (leveling) is not possible.
271		Press RESET Finish mission. Notify maintenance.	Warning - Degraded Operation Left oscillation valve - short circuit. Cable to valve defective.	Uncontrolled oscillation (leveling) may occur.

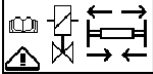
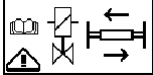
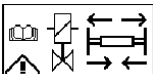
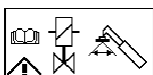
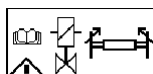
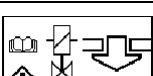
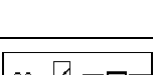
Table 4. Error Codes - Continued.

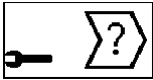
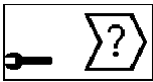
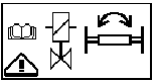
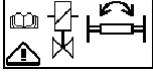
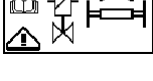
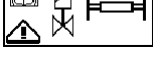
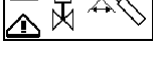

ERROR CODE	DISPLAY LAYOUT	DRIVER ACTION	ERROR CODE EXPLANATION	VEHICLE LIMITATIONS
300		Stop Vehicle Shut engine OFF for 30 seconds, then start vehicle. If code clears, resume mission. If code remains, notify maintenance.	Stop Vehicle Immediately Steering system malfunction. Steering computer - hardware error (EPROM, watchdog, reference voltages, etc.)	No steering or driving functions are available. Reduced power and engine speed.
301 302 303 304 305 306 307 308		Stop Vehicle Press RESET. Finish mission. Notify maintenance.	Warning - Degraded Operation One track of actual value potentiometer out of range (e.g., cable interrupted). Wheel 1, track 1. Wheel 2, track 1. Wheel 3, track 1. Wheel 4, track 1. Wheel 1, track 2. Wheel 2, track 2. Wheel 3, track 2. Wheel 4, track 2.	Stop vehicle by switching to NEUTRAL. Steering system will operate but is not redundant.
309 310 311 312		Stop Vehicle Abort mission. Notify maintenance.	Stop Vehicle Immediately Both tracks of actual value potentiometer out of range. Wheel 1. Wheel 2. Wheel 3. Wheel 4.	Stop vehicle by switching to NEUTRAL. Faulty wheel is locked immediately. Other wheels remain operational. Reduced power and engine speed.
313 314 315 316		Stop Vehicle Abort mission. Notify maintenance.	Stop Vehicle Immediately Deviation between two potentiometer tracks, but both inside tolerance range. Wheel 1. Wheel 2. Wheel 3. Wheel 4.	Stop vehicle by switching to NEUTRAL. Steering system will operate but is not redundant. Reduced power and engine speed.

Table 4. Error Codes - Continued.

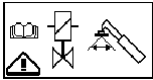
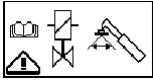
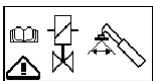
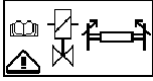
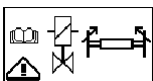
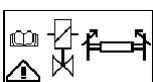
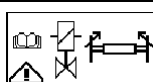

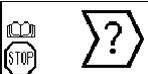
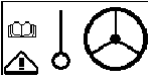

ERROR CODE	DISPLAY LAYOUT	DRIVER ACTION	ERROR CODE EXPLANATION	VEHICLE LIMITATIONS
317 318 319 320		Stop Vehicle Check wheel for blockage. If blocked, remove blockage and press RESET. If not blocked, notify maintenance.	Stop Vehicle Immediately Steering deviation between set point and actual value (tracking error). Wheel 1. Wheel 2. Wheel 3. Wheel 4.	Stop vehicle by switching to NEUTRAL. Steering remains active and tries to close up to set point. System will be active as soon as deviating wheel has closed up. Reduced power and engine speed.
321 322 323 324		Stop Vehicle Notify maintenance.	Stop Vehicle Immediately Wheel alignment values out of range. Wheel 1. Wheel 2. Wheel 3. Wheel 4.	This error prohibits driving after steering calibration if calibration was not successful or calibration values are out of range. Reduced power and engine speed.
325 326 327 328		Stop Vehicle Notify maintenance.	Stop Vehicle Immediately Break in cable to proportional valve. Wheel 1. Wheel 2. Wheel 3. Wheel 4.	Stop vehicle by switching to NEUTRAL. Steering computer cannot control wheel with broken cable. Faulty wheel has to be aligned by manual operation of valve. Reduced power and engine speed.
329 330 331 332		Stop Vehicle Abort mission. Notify maintenance.	Stop Vehicle Immediately Cable to proportional valve - short circuit. Wheel 1. Wheel 2. Wheel 3. Wheel 4.	Stop vehicle by switching to NEUTRAL. Steering computer cannot control wheel with broken cable. Faulty wheel has to be aligned by manual operation of valve. Reduced power and engine speed.
339		Stop Vehicle Abort mission. Notify maintenance.	Stop Vehicle Immediately Steering wheel sensor malfunction. Possible loss of ground.	Steering system out of order. No steering or driving functions are available.

Table 4. Error Codes - Continued.

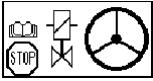

ERROR CODE	DISPLAY LAYOUT	DRIVER ACTION	ERROR CODE EXPLANATION	VEHICLE LIMITATIONS
340		Stop Vehicle Press RESET. Finish mission. Notify maintenance.	Warning - Degraded Operation Supply pressure below 1450 psi (100 bar). Leaking hydraulics.	Stop vehicle by switching to NEUTRAL. Steering system will operate in a degraded mode.
341		Stop Vehicle Abort mission. Notify maintenance.	Stop Vehicle Immediately Steering wheel signals inconsistent (e.g., two incremental counters deviating). Cables defective. Steering column sensor defective.	Stop vehicle by switching to NEUTRAL. Steering system will operate but is not redundant. Steering computer uses one of two counters to steer vehicle. Reduced power and engine speed.
342 343		Stop Vehicle Press RESET. Finish mission. Notify maintenance.	Warning - Degraded Operation One pulse signal to steering wheel interrupted. Cables defective. Steering column sensor defective.	Stop vehicle by switching to NEUTRAL. Steering system will operate but is not redundant. Steering computer uses uninterrupted signal to steer vehicle.
344		Stop Vehicle Abort mission. Notify maintenance.	Stop Vehicle Immediately Both pulse signals to steering wheel interrupted. Cables defective. Steering column sensor defective.	Stop vehicle by switching to NEUTRAL. Steering system will not operate. Reduced power and engine speed.
345		Finish Mission Shut engine OFF/ON. If code clears, resume mission. If code remains, notify maintenance.	Warning - Degraded Operation No CAN communication to display. Cable defective.	Error codes from steering ECU will not show on display. Steering function is operational.
346		Finish Mission Shut engine OFF/ON. If code clears, resume mission. If code remains, notify maintenance.	Warning - Degraded Operation No CAN communication to transmission. Cables defective.	It is not possible to change from 2WD to 4WD or vice versa. Steering system remains operational, but steering features dependent on driving speed are not available. To keep vehicle in full operation, steering program selection is allowed at this time.

Table 4. Error Codes - Continued.

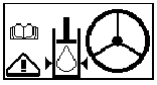

ERROR CODE	DISPLAY LAYOUT	DRIVER ACTION	ERROR CODE EXPLANATION	VEHICLE LIMITATIONS
347		Select Steering Mode	Information/Maintenance No valid steering program selected.	None.
350 351 352 353		Stop Vehicle Abort mission. Notify maintenance. Wheel 1 Wheel 2 Wheel 3 Wheel 4	Steering Valve Solenoid This error code occurs if the resistance differs from the preset value.	Stop vehicle by switching to NEUTRAL. Steering system will not operate properly.
354 355 356 357		Stop Vehicle Abort mission. Notify maintenance. Wheel 1 Wheel 2 Wheel 3 Wheel 4	Start-up Failure in Steering System This error code is caused by incorrect parameter settings in steering computer.	Stop vehicle by switching to NEUTRAL. Steering system will not operate properly.
399		Press RESET Finish mission. Notify maintenance.	EEPROM Parameter Error in Steering Computer One or more parameter values inside EEPROM are out of range.	Fully operational. History storage of error codes may not be possible.
401		Stop Vehicle Press RESET. Finish mission. Notify maintenance.	Warning - Degraded Operation Digital output short circuit - "Enable driving" (no neutral gear from steering ECU). Cables defective.	Transmission will not go into neutral automatically.
404		Finish Mission Notify maintenance.	Information/Maintenance Digital output short circuit - "Control lamp, front wheel steering." Cables defective.	Control lamp on steering selection switch is not working.

Table 4. Error Codes - Continued.

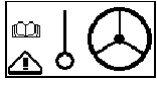
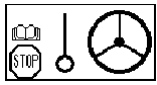
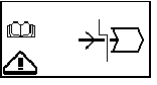
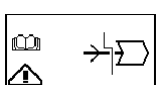
ERROR CODE	DISPLAY LAYOUT	DRIVER ACTION	ERROR CODE EXPLANATION	VEHICLE LIMITATIONS
405		Finish Mission Notify maintenance.	Information/Maintenance Digital output short circuit - <i>“Control lamp, four wheel steering.”</i> Cables defective.	Control lamp on steering selection switch is not working.
406		Finish Mission Notify maintenance.	Information/Maintenance Digital output short circuit - <i>“Control lamp, crab steering”</i> Cables defective.	Control lamp on steering selection switch is not working.
408		Finish Mission Notify maintenance.	Information/Maintenance Digital output short circuit - <i>“Control lamp, unlocked twistlock.”</i> Cables defective.	Control lamp on steering column is not working.
409		Finish Mission Notify maintenance.	Information/Maintenance Digital output short circuit - <i>“Control lamp, locked twistlock.”</i> Cables defective.	Control lamp on steering column is not working.
410		Finish Mission Notify maintenance.	Information/Maintenance Digital output short circuit - <i>“Control lamp, alignment.”</i> Cables defective.	Control lamp on steering column is not working.
411		Finish Mission Notify maintenance.	Information/Maintenance Digital output short circuit - <i>“Auxiliary hydraulic pump.”</i> Cables defective.	Cab cannot be moved. No emergency operation of boom or tophandler available.
412		Finish Mission Notify maintenance.	Information/Maintenance Digital output short circuit - <i>“Ether start kit.”</i> Cables defective.	Ether start not working.
413		Finish Mission Notify maintenance.	Information/Maintenance Digital output short circuit - <i>“Oil supply valve, boom folding.”</i> Cables defective.	Boom cannot be folded.

Table 4. Error Codes - Continued.

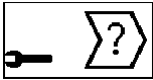

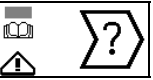
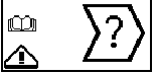
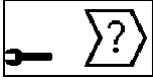

ERROR CODE	DISPLAY LAYOUT	DRIVER ACTION	ERROR CODE EXPLANATION	VEHICLE LIMITATIONS
414		Stop Vehicle Press RESET. Finish mission. Notify maintenance.	Warning - Degraded Operation Digital output short circuit - "Drive axle cooling, bypass valves." Cables defective.	Brakes may be overheated. Error codes 191 and 192 will show if brakes have overheated.
415		Stop Vehicle Abort mission. Notify maintenance.	Digital output short circuit	Reduced power and engine speed.
416		Stop Vehicle Press RESET. Finish mission. Notify maintenance.	Warning - Degraded Operation Digital input not read correctly - "Steering pressure." Cables defective.	Steering pressure failure cannot be detected, error code 340.
417		Finish Mission Notify maintenance.	Information/Maintenance Digital input not read correctly - "Auxiliary hydraulic pump switch." Cables defective.	Auxiliary hydraulic pump cannot be started.
418		Stop Vehicle Press RESET. Finish mission. Notify maintenance.	Warning - Degraded Operation Digital input not read correctly - "Front wheel steering switch." Cables defective.	2WD cannot be selected.
419		Stop Vehicle Press RESET. Finish mission. Notify maintenance.	Warning - Degraded Operation Digital input not read correctly - "Four wheel steering switch" Cables defective.	4WD cannot be selected.
420		Stop Vehicle Press RESET. Finish mission. Notify maintenance.	Warning - Degraded Operation Digital input not read correctly - "Crab steering switch." Cables defective.	Crab steering cannot be selected.

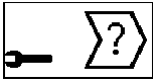
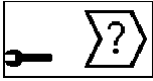
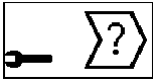
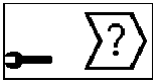
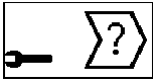
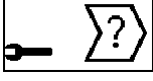
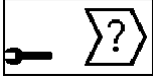
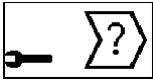
Table 4. Error Codes - Continued.

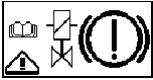
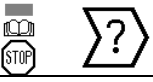

ERROR CODE	DISPLAY LAYOUT	DRIVER ACTION	ERROR CODE EXPLANATION	VEHICLE LIMITATIONS
422		Finish Mission Notify maintenance.	Information/Maintenance Digital input not read correctly - "Sensor, cab in transport position." Cables defective. Steering computer damaged.	Boom folding is not possible.
423		Finish Mission Notify maintenance.	Information/Maintenance Digital input not read correctly - "Ether start switch." Cables defective. Steering computer damaged.	Ether injection is not possible.
426		Stop Vehicle Press RESET. Finish mission. Notify maintenance.	Warning - Degraded Operation Digital input not read correctly - "Fording level switch." Cables defective. Steering computer damaged.	Fording operations are not possible.
427		Finish Mission Notify maintenance.	Information/Maintenance Digital input not read correctly - "Tophandler work light switch." Cables defective. Steering computer damaged.	Work lights on tophandler do not function.
440		Stop Vehicle Abort mission. Notify maintenance.	Error on Power Supply for Steering Wheel Sensor Error code can be caused by: Short circuit of analog output terminal 38 to +24V. Short circuit of analog output terminal 38 to ground. Fault in steering computer output.	Steering wheel has no end positions or steering resistance.
450		Stop Vehicle Press RESET. Finish mission. Notify maintenance.	Warning - Degraded Operation Ambient temperature too high. Temperature sensor defective. ECU 792 defective.	None.

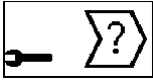
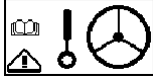
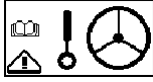
Table 4. Error Codes - Continued.

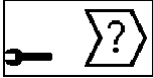
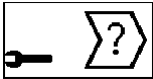
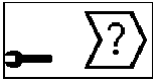
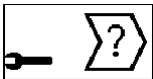

ERROR CODE	DISPLAY LAYOUT	DRIVER ACTION	ERROR CODE EXPLANATION	VEHICLE LIMITATIONS
451		Stop Vehicle Press RESET. Finish mission. Notify maintenance.	Warning - Degraded Operation Supply voltage too high. Alternator defective.	Stop vehicle by switching to neutral.
452		Stop Vehicle Press RESET. Notify maintenance.	Warning - Degraded Operation Supply voltage too low. Power supply off. Alternator defective.	Stop vehicle by switching to neutral.
453		Stop Vehicle Abort mission. Notify maintenance.	Supply Voltage for Wheel Sensors Out of Range The +5 supply voltage for angle transducer track 2 is too low. Error code can be caused by short circuit in one or more angle transducer tracks or low impedance to ground.	The vehicle is stopped by switching to neutral gear. If error code 453 is also active, all wheels are locked.
454		Stop Vehicle Abort mission. Notify maintenance.	Supply Voltage for Wheel Sensors Out of Range The +5 supply voltage for angle transducer track 1 is too low. Error code can be caused by short circuit in one or more angle transducer tracks or low impedance to ground.	The vehicle is stopped by switching to neutral gear. If error code 454 is also active, all wheels are locked.
618		Stop Vehicle Press RESET. If error shows again, notify maintenance. Finish mission.	Warning - Degraded Operation Logical error at direction select signal - transmission ECU detected incorrect signal combination for the direction. Cables defective. Shift lever defective.	Stop vehicle by switching to neutral.
622		Press RESET If error shows again, notify maintenance. Finish mission.	Information/Maintenance Logical error at axle connection - axle connection feedback measured by transmission ECU and output signal do not match Cables defective. Switch defective. Mechanical error.	When shifting from 2WD to 4WD or vice versa, engage forward drive and immediately return to neutral. Turn the ignition switch off for at least 30 seconds, then turn switch back on.

Table 4. Error Codes - Continued.





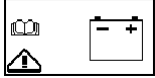
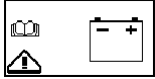
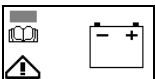
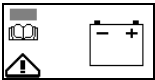
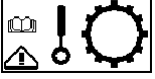



ERROR CODE	DISPLAY LAYOUT	DRIVER ACTION	ERROR CODE EXPLANATION	VEHICLE LIMITATIONS
637		Finish Mission Notify maintenance.	Information/Maintenance Short circuit to battery voltage or open circuit at transmission sump temperature sensor input - voltage too high. Cables defective. Sensor defective. Connector pin broken.	None.
638		Finish Mission Notify maintenance.	Information/Maintenance Short circuit to ground at transmission sump temperature sensor input - voltage too low. Cables defective. Sensor defective. Connector pin broken.	None.
639		Finish Mission Notify maintenance.	Information/Maintenance Short circuit to battery voltage or open circuit at converter output temperature sensor input - voltage too high. Cables defective. Sensor defective. Connector pin broken.	None.
640		Finish Mission Notify maintenance.	Information/Maintenance Short circuit to battery voltage or open circuit at converter output temperature sensor input - voltage too low. Cables defective. Sensor defective. Connector pin broken.	None.

Table 4. Error Codes - Continued.

ERROR CODE	DISPLAY LAYOUT	DRIVER ACTION	ERROR CODE EXPLANATION	VEHICLE LIMITATIONS
649		Finish Mission Notify maintenance.	Information/Maintenance Short circuit to battery voltage or open circuit at engine speed input - transmission ECU measures a voltage higher than 7.0V at speed input pin. Cables defective. Sensor defective. Connector pin broken.	Gearshift quality is reduced, due to another control mode (operating mode: substitute clutch control).
650		Finish Mission Notify maintenance.	Information/Maintenance Short circuit to ground at engine speed input - transmission ECU measures a voltage less than 0.45V at speed input pin. Cables defective. Sensor defective.	Gearshift quality is reduced, due to another control mode (operating mode: substitute clutch control).
650		Finish Mission Notify maintenance.	Information/Maintenance Short circuit to ground at engine speed input - transmission ECU measures a voltage less than 0.45V at speed input pin. Cables defective. Sensor defective.	Gearshift quality is reduced, due to another control mode (operating mode: substitute clutch control).
651		Finish Mission Notify maintenance.	Information/Maintenance Logical error at engine speed input - transmission ECU measures engine speed over a threshold and the next moment the measured speed is zero. Cables defective. Sensor defective. Incorrect sensor gap size.	Gearshift quality is reduced, due to another control mode (operating mode: substitute clutch control).
652		Press RESET Finish mission. Notify maintenance.	Warning - Degraded Operation Short circuit to battery voltage or open circuit at turbine speed input - transmission ECU measures a voltage higher than 7.0V at speed input pin. Cables defective. Sensor defective. Incorrect sensor gap size.	Gearshift quality is reduced, due to another control mode (operating mode: substitute clutch control). If there is also a failure at output speed, transmission ECU shifts to neutral. Limp home.



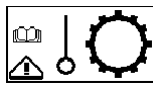

ERROR CODE	DISPLAY LAYOUT	DRIVER ACTION	ERROR CODE EXPLANATION	VEHICLE LIMITATIONS
653		Press RESET Finish mission. Notify maintenance.	Warning - Degraded Operation Short circuit to ground at turbine speed input - transmission ECU measures a voltage less than 0.45V at speed input pin. Cables defective. Sensor defective.	Gearshift quality is reduced, due to another control mode (operating mode: substitute clutch control). If there is also a failure at output speed, transmission ECU shifts to neutral. Limp home.
654		Press RESET Finish mission. Notify maintenance.	Warning - Degraded Operation Logical error at turbine speed input - transmission ECU measures turbine speed over a threshold and at the next moment the measured speed is zero. Cables defective. Sensor defective. Incorrect sensor gap size.	Gearshift quality is reduced, due to another control mode (operating mode: substitute clutch control). If there is also a failure at output speed, transmission ECU shifts to neutral. Limp home.
655		Finish Mission Notify maintenance.	Information/Maintenance Short circuit to battery voltage or open circuit at internal speed input - transmission ECU measures a voltage higher than 7.0V at speed input pin. Cables defective. Sensor defective.	Gearshift quality is reduced, due to another control mode (operating mode: substitute clutch control).
656		Finish Mission Notify maintenance.	Information/Maintenance Short circuit to ground at internal speed input - transmission ECU measures a voltage less than 0.45V at speed input pin. Cables defective. Sensor defective.	Gearshift quality is reduced, due to another control mode (operating mode: substitute clutch control).
657		Press RESET Finish mission. Notify maintenance.	Information/Maintenance Logical error at internal speed input - transmission ECU measures internal speed over a threshold and at the next moment the measured speed is zero. Cables defective. Sensor defective. Incorrect sensor gap size.	Gearshift quality is reduced, due to another control mode (operating mode: substitute clutch control). If there is also a failure at output speed, transmission ECU shifts to neutral. Limp home.

Table 4. Error Codes - Continued.



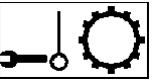

ERROR CODE	DISPLAY LAYOUT	DRIVER ACTION	ERROR CODE EXPLANATION	VEHICLE LIMITATIONS
658		Stop Vehicle Press RESET. Finish mission. Notify maintenance.	Warning - Degraded Operation Short circuit to battery voltage or open circuit at output speed input - transmission ECU measures a voltage higher than 12.5V at speed input pin. Cables defective. Sensor defective.	Gearshift quality is reduced, due to another control mode (operating mode: substitute clutch control). If there is also a failure at turbine speed, transmission ECU shifts to neutral. Limp home.
659		Stop Vehicle Press RESET. Finish mission. Notify maintenance.	Warning - Degraded Operation Short circuit to battery voltage at output speed input - transmission ECU measures a voltage less than 1.0V at speed input pin. Cables defective. Sensor defective.	Gearshift quality is reduced, due to another control mode (operating mode: substitute clutch control). If there is also a failure at turbine speed, transmission ECU shifts to neutral. Limp home.
660		Stop Vehicle Press RESET. Finish mission. Notify maintenance.	Warning - Degraded Operation Logical error at output speed input - transmission ECU measures internal speed over a threshold and at the next moment the measured speed is zero. Cables defective. Sensor defective.	Gearshift quality is reduced, due to another control mode (operating mode: substitute clutch control). If there is also a failure at turbine speed, transmission ECU shifts to neutral. Limp home.
662		Stop Vehicle Press RESET. Finish mission. Notify maintenance.	Warning - Degraded Operation Output speed does not fit other speed signals. If transmission is not in neutral and shifting has finished, transmission ECU measures output speed as zero and turbine or internal speed as not equal to zero. Cables defective. Sensor defective. Incorrect sensor gap size.	Gearshift quality is reduced, due to another control mode (operating mode: substitute clutch control). If there is also a failure at turbine speed, transmission ECU shifts to neutral. Limp home.

Table 4. Error Codes - Continued.

ERROR CODE	DISPLAY LAYOUT	DRIVER ACTION	ERROR CODE EXPLANATION	VEHICLE LIMITATIONS
684		Finish Mission Shut engine off/on. If code clears, resume mission. If code remains, notify maintenance.	Warning - Degraded Operation CAN message time-out from display computer. Cable defective. Defective display computer.	Error codes from transmission ECU will not show.
685		Finish Mission Shut engine OFF/ON. If code clears, resume mission. If code remains, notify maintenance.	Warning - Degraded Operation CAN message time-out from display computer. Cable defective. Defective steering computer.	Error codes from transmission ECU will not show.
713		Stop Vehicle Abort mission. Notify maintenance.	Stop Vehicle Immediately Short circuit to battery voltage at clutch K1 - measured valve resistance is beyond limit, voltage at K1 valve is too high. Cables defective. Regulator defective.	Transmission ECU shifts to neutral. Limp home. If there is also a failure at another clutch, ECU shifts to neutral. ECU will shut down. Reduced power and engine speed.
714		Stop Vehicle Abort mission. Notify maintenance.	Stop Vehicle Immediately Short circuit to ground at clutch K1 - measured valve resistance is beyond limit, voltage at K1 valve is too low. Cables defective. Regulator defective.	Transmission ECU shifts to neutral. Limp home. If there is also a failure at another clutch, ECU shifts to neutral. ECU will shut down Reduced power and engine speed.
715		Stop Vehicle Abort mission. Notify maintenance.	Stop Vehicle Immediately Open circuit at clutch K1 - measured valve resistance is beyond limit. Cables defective. Regulator defective.	Transmission ECU shifts to neutral. Limp home. If there is also a failure at another clutch, ECU shifts to neutral. ECU will shut down. Reduced power and engine speed.

Table 4. Error Codes - Continued.



ERROR CODE	DISPLAY LAYOUT	DRIVER ACTION	ERROR CODE EXPLANATION	VEHICLE LIMITATIONS
716		Stop Vehicle Abort mission. Notify maintenance.	Stop Vehicle Immediately Short circuit to battery voltage at clutch K2 - measured valve resistance is beyond limit, voltage at K2 valve is too high. Cables defective. Regulator defective.	Transmission ECU shifts to neutral. Limp home. If there is also a failure at another clutch, ECU shifts to neutral. ECU will shut down. Reduced power and engine speed.
717		Stop Vehicle Abort mission. Notify maintenance.	Stop Vehicle Immediately Short circuit to ground at clutch K2 - measured valve resistance is beyond limit, voltage at K2 valve is too low. Cables defective. Regulator defective.	Transmission ECU shifts to neutral. Limp home. If there is also a failure at another clutch, ECU shifts to neutral. ECU will shut down. Reduced power and engine speed.
718		Stop Vehicle Abort mission. Notify maintenance.	Stop Vehicle Immediately Open circuit at clutch K2 - measured valve resistance is beyond limit. Cables defective. Regulator defective.	Transmission ECU shifts to neutral. Limp home. If there is also a failure at another clutch, ECU shifts to neutral. ECU will shut down. Reduced power and engine speed.
719		Stop Vehicle Abort mission. Notify maintenance.	Stop Vehicle Immediately Short circuit to battery voltage at clutch K3 - measured valve resistance is beyond limit, voltage at K3 valve is too high. Cables defective. Regulator defective.	Transmission ECU shifts to neutral. Limp home. If there is also a failure at another clutch, ECU shifts to neutral. ECU will shut down. Reduced power and engine speed.
720		Stop Vehicle Abort mission. Notify maintenance.	Stop Vehicle Immediately Short circuit to ground at clutch K3 - measured valve resistance is beyond limit, voltage at K3 valve is too low. Cables defective. Regulator defective.	Transmission ECU shifts to neutral. Limp home. If there is also a failure at another clutch, ECU shifts to neutral. ECU will shut down. Reduced power and engine speed.

Table 4. Error Codes - Continued.

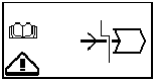
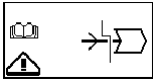
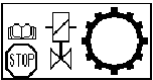
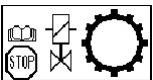
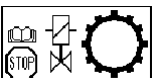

ERROR CODE	DISPLAY LAYOUT	DRIVER ACTION	ERROR CODE EXPLANATION	VEHICLE LIMITATIONS
721		Stop Vehicle Abort mission. Notify maintenance.	Stop Vehicle Immediately Open circuit at clutch K3 - measured valve resistance is beyond limit. Cables defective. Regulator defective.	Transmission ECU shifts to neutral. Limp home. If there is also a failure at another clutch, ECU shifts to neutral. ECU will shut down. Reduced power and engine speed.
729		Stop Vehicle Abort mission. Notify maintenance.	Stop Vehicle Immediately Short circuit to battery voltage at clutch K4 - measured valve resistance is beyond limit, voltage at K4 valve is too high. Cables defective. Regulator defective.	Transmission ECU shifts to neutral. Limp home. If there is also a failure at another clutch, ECU shifts to neutral. ECU will shut down. Reduced power and engine speed.
730		Stop Vehicle Abort mission. Notify maintenance.	Stop Vehicle Immediately Short circuit to ground at clutch K4 - measured valve resistance is beyond limit, voltage at K4 valve is too low. Cables defective. Regulator defective.	Transmission ECU shifts to neutral. Limp home. If there is also a failure at another clutch, ECU shifts to neutral. ECU will shut down. Reduced power and engine speed.
731		Stop Vehicle Abort mission. Notify maintenance.	Stop Vehicle Immediately Open circuit at clutch K4 - measured valve resistance is beyond limit. Cables defective. Regulator defective.	Transmission ECU shifts to neutral. Limp home. If there is also a failure at another clutch, ECU shifts to neutral. ECU will shut down. Reduced power and engine speed.

Table 4. Error Codes - Continued.

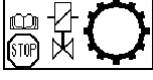
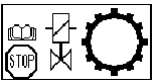

ERROR CODE	DISPLAY LAYOUT	DRIVER ACTION	ERROR CODE EXPLANATION	VEHICLE LIMITATIONS
732		Stop Vehicle Abort mission. Notify maintenance.	Stop Vehicle Immediately Short circuit to battery voltage at clutch KV - measured valve resistance is beyond limit, voltage at KV valve is too high. Cables defective. Regulator defective.	Transmission ECU shifts to neutral. Limp home. If there is also a failure at another clutch, ECU shifts to neutral. ECU will shut down. Reduced power and engine speed.
733		Stop Vehicle Abort mission. Notify maintenance.	Stop Vehicle Immediately Short circuit to ground at clutch KV - measured valve resistance is beyond limit, voltage at KV valve is too low. Cables defective. Regulator defective.	Transmission ECU shifts to neutral. Limp home. If there is also a failure at another clutch, ECU shifts to neutral. ECU will shut down. Reduced power and engine speed.
734		Stop Vehicle Abort mission. Notify maintenance.	Stop Vehicle Immediately Open circuit at clutch KV - measured valve resistance is beyond limit. Cables defective. Regulator defective.	Transmission ECU shifts to neutral. Limp home. If there is also a failure at another clutch, ECU shifts to neutral. ECU will shut down. Reduced power and engine speed.
735		Stop Vehicle Abort mission. Notify maintenance.	Stop Vehicle Immediately Short circuit to battery voltage at clutch KR - measured valve resistance is beyond limit, voltage at KR valve is too high. Cables defective. Regulator defective.	Transmission ECU shifts to neutral. Limp home. If there is also a failure at another clutch, ECU shifts to neutral. ECU will shut down. Reduced power and engine speed.
736		Stop Vehicle Abort mission. Notify maintenance.	Stop Vehicle Immediately Short circuit to ground at clutch KR - measured valve resistance is beyond limit, voltage at KR valve is too low. Cables defective. Regulator defective.	Transmission ECU shifts to neutral. Limp home. If there is also a failure at another clutch, ECU shifts to neutral. ECU will shut down. Reduced power and engine speed.

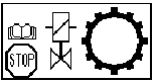
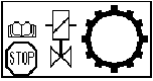
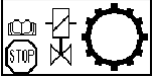
Table 4. Error Codes - Continued.



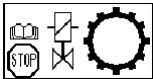

ERROR CODE	DISPLAY LAYOUT	DRIVER ACTION	ERROR CODE EXPLANATION	VEHICLE LIMITATIONS
737		Stop Vehicle Abort mission. Notify maintenance.	Stop Vehicle Immediately Open circuit at clutch KR - measured valve resistance is beyond limit. Cables defective. Regulator defective.	Transmission ECU shifts to neutral. Limp home. If there is also a failure at another clutch, ECU shifts to neutral. ECU will shut down. Reduced power and engine speed.
745		Finish Mission Notify maintenance.	Information/Maintenance Short circuit to ground at reverse warning alarm relay - transmission ECU detected incorrect voltage at output pin that looks like a short circuit to battery voltage. Cables defective. Backup alarm device defective.	None.
746		Finish Mission Notify maintenance.	Information/Maintenance Short circuit to battery voltage at reverse warning alarm relay - transmission ECU detected incorrect voltage at output pin that looks like a short circuit to battery voltage. Cables defective. Backup alarm device defective.	None.
747		Finish Mission Notify maintenance.	Information/Maintenance Open circuit at reverse warning alarm relay - transmission ECU detected incorrect voltage at output pin that looks like an open circuit for this output pin. Cables defective. Backup alarm device defective.	None.
761		Stop Vehicle Press RESET. Finish mission. Notify maintenance.	Warning - Degraded Operation Short circuit to ground at axle connection solenoid - transmission ECU detected incorrect voltage at output pin that looks like a short circuit to vehicle ground. Cables defective. Axle connection solenoid defective.	Switching from 2WD to 4WD is not possible.

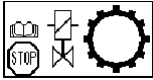
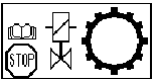
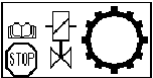
Table 4. Error Codes - Continued.

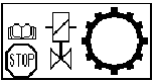

ERROR CODE	DISPLAY LAYOUT	DRIVER ACTION	ERROR CODE EXPLANATION	VEHICLE LIMITATIONS
762		Stop Vehicle Press RESET. Finish mission. Notify maintenance.	Warning - Degraded Operation Short circuit to battery voltage axle connection solenoid - transmission ECU detected incorrect voltage at output pin that looks like a short circuit to battery voltage. Cables defective. Axle connection solenoid defective.	Switching from 2WD to 4WD is not possible.
763		Stop Vehicle Press RESET. Finish mission. Notify maintenance.	Warning - Degraded Operation Open circuit at axle connection solenoid - transmission ECU detected incorrect voltage at output pin that looks like an open circuit for this output pin. Cables defective. Axle connection solenoid defective.	Switching from 2WD to 4WD is not possible.
777		Stop Vehicle Abort mission. Notify maintenance.	Stop Vehicle Immediately Slippage at clutch K1 - transmission ECU calculates a differential speed at closed clutch K1. If this calculated value is outside range, ECU interprets this as a slipping clutch. Low pressure. Sensor defective. Incorrect sensor gap size. Clutch defective.	Transmission ECU shifts to neutral. Limp home. If there is also a failure at another clutch, ECU shifts to neutral. ECU will shut down. Reduced power and engine speed.
778		Stop Vehicle Abort mission. Notify maintenance.	Stop Vehicle Immediately Slippage at clutch K2 - transmission ECU calculates a differential speed at closed clutch K2. If this calculated value is outside range, ECU interprets this as a slipping clutch. Low pressure. Sensor defective. Incorrect sensor gap size. Clutch defective.	Transmission ECU shifts to neutral. Limp home. If there is also a failure at another clutch, ECU shifts to neutral. ECU will shut down. Reduced power and engine speed.

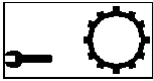
Table 4. Error Codes - Continued.

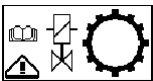

ERROR CODE	DISPLAY LAYOUT	DRIVER ACTION	ERROR CODE EXPLANATION	VEHICLE LIMITATIONS
779		Stop Vehicle Abort mission. Notify maintenance.	Stop Vehicle Immediately Slippage at clutch K3 - transmission ECU calculates a differential speed at closed clutch K3. If this calculated value is outside range, ECU interprets this as a slipping clutch. Low pressure. Sensor defective. Incorrect sensor gap size. Clutch defective.	ECU shifts to neutral. Limp home. If there is also a failure at another clutch, ECU shifts to neutral. ECU will shut down. Reduced power and engine speed.
780		Stop Vehicle Abort mission. Notify maintenance.	Stop Vehicle Immediately Slippage at clutch K4 - transmission ECU calculates a differential speed at closed clutch K4. If this calculated value is outside range, ECU interprets this as a slipping clutch. Low pressure. Sensor defective. Incorrect sensor gap size. Clutch defective.	Transmission ECU shifts to neutral. Limp home. If there is also a failure at another clutch, ECU shifts to neutral. ECU will shut down. Reduced power and engine speed.
781		Stop Vehicle Abort mission. Notify maintenance.	Stop Vehicle Immediately Slippage at clutch KV - transmission ECU calculates a differential speed at closed clutch KV. If this calculated value is outside range, ECU interprets this as a slipping clutch. Low pressure. Sensor defective. Incorrect sensor gap size. Clutch defective.	Transmission ECU shifts to neutral. Limp home. If there is also a failure at another clutch, ECU shifts to neutral. ECU will shut down. Reduced power and engine speed.

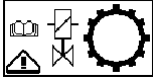
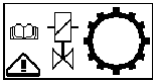
Table 4. Error Codes - Continued.





ERROR CODE	DISPLAY LAYOUT	DRIVER ACTION	ERROR CODE EXPLANATION	VEHICLE LIMITATIONS
782		Stop Vehicle Abort mission. Notify maintenance.	Stop Vehicle Immediately Slippage at clutch KR - transmission ECU calculates a differential speed at closed clutch KR. If this calculated value is outside of range, ECU interprets this as a slipping clutch. Low pressure. Sensor defective. Incorrect sensor gap size. Clutch defective.	Transmission ECU shifts to neutral. Limp home. If there is also a failure at another clutch, ECU shifts to neutral. ECU will shut down. Reduced power and engine speed.
783		Stop Vehicle Check oil level. Allow transmission to cool down. Press RESET. If error shows again, notify maintenance. Finish mission.	Warning - Degraded Operation Overheated sump - transmission ECU measured temperature in oil sump that is over 212°F (100°C). Low oil level. Temperature sensor defective.	None.
786		Finish Mission Notify maintenance.	Information/Maintenance Oil filter differential pressure - transmission ECU measured a voltage at differential pressure switch outside allowable range. Oil filter polluted. Cable/connector defective. Differential switch defective.	None.
795		Stop Vehicle Check oil level. Allow transmission to cool down. Press RESET. If error shows again, notify maintenance. Finish mission.	Warning - Degraded Operation Overheated converter output - ECU measured oil temperature at converter output that is over 248°F (120°C). Low oil level. Temperature sensor defective.	None.
811		Stop Vehicle Abort mission. Notify maintenance.	Stop Vehicle Immediately Low power at battery - measured voltage at power supply is lower than 18V. Cable defective. Battery defective. Connector defective.	Transmission ECU shifts to neutral. ECU will shut down. Reduced power and engine speed.

Table 4. Error Codes - Continued.



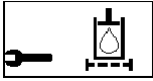

ERROR CODE	DISPLAY LAYOUT	DRIVER ACTION	ERROR CODE EXPLANATION	VEHICLE LIMITATIONS
812		Stop Vehicle Abort mission. Notify maintenance.	Stop Vehicle Immediately High power at battery - measured voltage at power supply is higher than 32.5V. Cable defective. Battery defective. Connector defective.	Transmission ECU shifts to neutral. ECU will shut down. Reduced power and engine speed.
813		Stop Vehicle Abort mission. Notify maintenance.	Stop Vehicle Immediately Error at shift valve power supply (VPS1). Cable defective. Connector defective. ECU defective.	ECU shifts to neutral. ECU will shut down. Reduced power and engine speed.
814		Stop Vehicle Abort mission. Notify maintenance.	Stop Vehicle Immediately Error at shift valve power supply (VPS2). Cable defective. Connector defective. ECU defective.	ECU shifts to neutral. ECU will shut down. Reduced power and engine speed.
841		Finish Mission Notify maintenance.	Information/Maintenance General EEPROM fault - ECU cannot read memory. ECU defective.	None.
843		Stop Vehicle Abort mission. Notify maintenance.	Stop Vehicle Immediately Application error ECU defective.	Transmission stays in neutral. ECU will shut down. Reduced power and engine speed.
845		Stop Vehicle Abort mission. Notify maintenance.	Stop Vehicle Immediately Clutch failure - AEB was not able to adjust clutch filling parameters. Clutch defective.	Transmission stays in neutral. ECU will shut down. Reduced power and engine speed.
846		Finish Mission Notify maintenance.	Information/Maintenance Clutch adjustment data lost - ECU was not able to read correct adjustment parameters Interference during data saving process.	None.

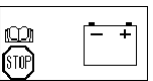
Table 4. Error Codes - Continued.

ERROR CODE	DISPLAY LAYOUT	DRIVER ACTION	ERROR CODE EXPLANATION	VEHICLE LIMITATIONS
1111		Engine Will Not Start - Notify Maintenance	Stop Vehicle Immediately ECM internal memory error. Hardware defective. Internal microprocessor communication failure.	Engine will not start. Reduced power and engine speed.
1115		Stop Vehicle Shut engine OFF for 30 seconds, then turn engine ON. If code clears, resume mission, then notify maintenance. If code remains, notify maintenance.	Stop Vehicle Immediately No engine speed signal detected in either engine position sensor circuits.	Engine will shut down and will not start. Reduced power and engine speed.
1121		Stop Vehicle Press RESET. If error shows again, notify maintenance. Finish mission.	Warning - Degraded Operation No engine speed signal detected in one engine position sensor circuit.	None.
1122		Stop Vehicle Press RESET. If error shows again, notify maintenance. Finish mission.	Warning - Degraded Operation High voltage detected in intake manifold pressure sensor circuit.	Reduced engine power output.
1123		Stop Vehicle Press RESET. If error shows again, notify maintenance. Finish mission.	Warning - Degraded Operation Low voltage detected in intake manifold pressure sensor circuit.	Reduced engine power output.
1131		Stop Vehicle Abort mission. Notify maintenance.	Stop Vehicle Immediately High voltage detected in throttle position sensor circuit.	Severe power and speed loss. Limp home power only. Reduced power and engine speed.
1132		Stop Vehicle Abort mission. Notify maintenance.	Stop Vehicle Immediately Low voltage detected in throttle position sensor circuit.	Severe power and speed loss. Limp home power only. Reduced power and engine speed.
1135		Stop Vehicle Press RESET. If error shows again, notify maintenance. Finish mission.	Warning - Degraded Operation High voltage detected in oil pressure sensor circuit.	Oil pressure warning not working.

Table 4. Error Codes - Continued.

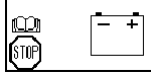
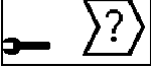
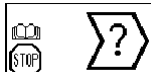

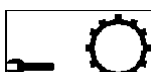

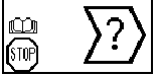
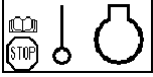
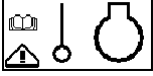
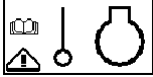
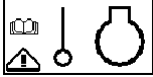
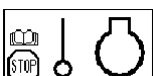
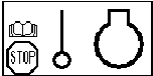
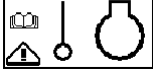

ERROR CODE	DISPLAY LAYOUT	DRIVER ACTION	ERROR CODE EXPLANATION	VEHICLE LIMITATIONS
1141		Stop Vehicle Press RESET. If error shows again, notify maintenance. Finish mission.	Warning - Degraded Operation Low voltage detected in oil pressure sensor circuit.	Oil pressure warning not working.
1143		Stop Vehicle Check oil level. Press RESET. If error shows again, notify maintenance. Finish mission.	Warning - Degraded Operation Oil pressure signal indicates low oil pressure.	Reduced power and speed. Engine will shut down in 30 to 45 seconds.
1144		Stop Vehicle Press RESET. If error shows again, notify maintenance. Finish mission.	Warning - Degraded Operation High voltage detected in coolant temperature circuit.	Temperature warning not functioning.
1145		Stop Vehicle Press RESET. If error shows again, notify maintenance. Finish mission.	Warning - Degraded Operation Low voltage detected in coolant temperature circuit.	Temperature warning not functioning.
1151		Stop Vehicle Check coolant level. If error remains, notify maintenance.	Stop Vehicle Immediately Coolant temperature signal indicated coolant temperature above critical threshold.	Reduced power and speed. Engine will shut down in 30 to 45 seconds.
1153		Stop Vehicle Press RESET. If error shows again, notify maintenance. Finish mission.	Warning - Degraded Operation High voltage detected in intake manifold temperature sensor circuit.	Possible white smoke. No engine protection for intake manifold temperature.
1154		Stop Vehicle Press RESET. If error shows again, notify maintenance. Finish mission.	Warning - Degraded Operation Low voltage detected in intake manifold temperature sensor circuit.	Possible white smoke. No engine protection for intake manifold temperature.
1155		Stop Vehicle Check coolant level. If error remains, notify maintenance.	Stop Vehicle Immediately Intake manifold temperature signal indicated coolant temperature above critical threshold.	Reduced power and speed. Engine will shut down in 30 to 45 seconds.

Table 4. Error Codes - Continued.

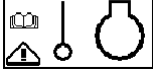

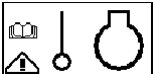
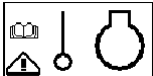

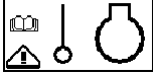
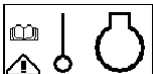

ERROR CODE	DISPLAY LAYOUT	DRIVER ACTION	ERROR CODE EXPLANATION	VEHICLE LIMITATIONS
1187		Stop Vehicle Press RESET. Finish mission. Notify maintenance.	Warning - Degraded Operation Low voltage detected on ECM voltage supply line to some sensors.	Engine will run degraded. No protection for oil pressure.
1212		Stop Vehicle Press RESET. If error shows again, notify maintenance. Finish mission.	Warning - Degraded Operation High voltage detected in oil temperature sensor circuit.	No engine protection for oil temperature.
1213		Stop Vehicle Press RESET. If error shows again, notify maintenance. Finish mission.	Warning - Degraded Operation Low voltage detected in oil temperature sensor circuit.	No engine protection for oil temperature.
1214		Stop Vehicle Check oil level. Press RESET. If error remains, notify maintenance. Finish mission.	Stop Vehicle Immediately Oil pressure signal indicates temperature above critical threshold.	Reduced power and speed.
1221		Finish Mission Notify maintenance.	Information/Maintenance High voltage detected in ambient air pressure sensor circuit.	Reduced power and speed.
1222		Finish Mission Notify maintenance.	Information/Maintenance Low voltage detected in ambient air pressure sensor circuit.	Reduced power and speed.
1227		Stop Vehicle Press RESET. Finish mission. Notify maintenance.	Warning - Degraded Operation High voltage detected on ECM voltage supply line to some sensors.	Engine will run degraded. No protection for oil pressure.
1234		Stop Vehicle Shut engine OFF/ON. If code clears, resume mission. If code remains, notify maintenance.	Stop Vehicle Immediately Engine speed signal indicates engine speed greater than 2,730 RPM.	Fuel shutoff valve is closed until engine speed drops. Fuel shutoff valve will open when engine speed falls below 2,184 RPM. Reduced power and engine speed.

Table 4. Error Codes - Continued.

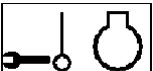
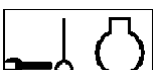

ERROR CODE	DISPLAY LAYOUT	DRIVER ACTION	ERROR CODE EXPLANATION	VEHICLE LIMITATIONS
1254		Stop Vehicle Shut engine OFF/ON. If code clears, resume mission. If code remains, notify maintenance.	Stop Vehicle Immediately Less than 6V detected at fuel shutoff driver. Excessive current draw. Power supply faulty.	ECM turns off FSO supply voltage. Engine will shut down. Reduced power and engine speed.
1255		Stop Vehicle Press RESET. Finish mission. Notify maintenance.	Warning - Degraded Operation Externally supplied voltage detected going to fuel shutoff supply circuit.	No performance limitations. Fuel shutoff valve stays open.
1285		Stop Vehicle Shut engine OFF/ON. If code clears, resume mission. If code remains, notify maintenance.	Warning - Degraded Operation Information from multiplexed device not received by ECM or received too late.	At least one multiplexed device will not operate properly.
1286		Stop Vehicle Shut engine OFF/ON. If code clears, resume mission. If code remains, notify maintenance.	Warning - Degraded Operation Only a portion of information from multiplexed device received by ECM.	At least one multiplexed device will not operate properly.
1287		Stop Vehicle Shut engine OFF/ON. If code clears, resume mission. If code remains, notify maintenance.	Stop Vehicle Immediately Data error received while multiplexing throttle pedal and IVS.	The engine will only idle. Reduced power and engine speed.
1295		Finish Mission Notify maintenance.	Information/Maintenance Ambient air pressure sensor circuit error detected by ECM.	Engine is degraded to no air setting.
1298		Stop Vehicle If code clears, resume mission.	Stop Vehicle Immediately Intake system indicates air cleaner is clogged.	Reduced power and speed.
1311		Finish Mission Notify maintenance.	Information/Maintenance Current detected at injector for cylinder #1 when voltage is turned OFF.	Injector for cylinder #1 turned OFF.
1312		Finish Mission Notify maintenance.	Information/Maintenance Current detected at injector for cylinder #5 when voltage is turned OFF.	Injector for cylinder #5 turned OFF.

Table 4. Error Codes - Continued.

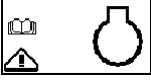
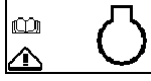

ERROR CODE	DISPLAY LAYOUT	DRIVER ACTION	ERROR CODE EXPLANATION	VEHICLE LIMITATIONS
1313		Finish Mission Notify maintenance.	Information/Maintenance Current detected at injector for cylinder #3 when voltage is turned OFF.	Injector for cylinder #3 turned OFF.
1314		Finish Mission Notify maintenance.	Information/Maintenance Current detected at injector for cylinder #6 when voltage is turned OFF.	Injector for cylinder #6 turned OFF.
1315		Finish Mission Notify maintenance.	Information/Maintenance Current detected at injector for cylinder #2 when voltage is turned OFF.	Injector for cylinder #2 turned OFF.
1321		Finish Mission Notify maintenance.	Information/Maintenance Current detected at injector for cylinder #4 when voltage is turned OFF.	Injector for cylinder #4 turned OFF.
1322		Finish Mission Notify maintenance.	Information/Maintenance No current detected at injector for cylinder #1 when voltage is turned ON.	Injector for cylinder #1 turned OFF.
1323		Finish Mission Notify maintenance.	Information/Maintenance No current detected at injector for cylinder #5 when voltage is turned ON.	Injector for cylinder #5 turned OFF.
1324		Finish Mission Notify maintenance.	Information/Maintenance No current detected at injector for cylinder #3 when voltage is turned ON.	Injector for cylinder #3 turned OFF.
1325		Finish Mission Notify maintenance.	Information/Maintenance No current detected at injector for cylinder #6 when voltage is turned ON.	Injector for cylinder #6 turned OFF.
1331		Finish Mission Notify maintenance.	Information/Maintenance No current detected at injector for cylinder #2 when voltage is turned ON.	Injector for cylinder #2 turned OFF.

Table 4. Error Codes - Continued.

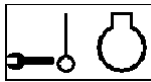
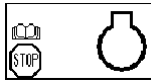
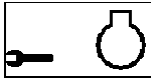
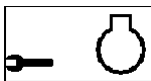

ERROR CODE	DISPLAY LAYOUT	DRIVER ACTION	ERROR CODE EXPLANATION	VEHICLE LIMITATIONS
1332		Finish Mission Notify maintenance.	Information/Maintenance No current detected at injector for cylinder #4 when voltage is turned ON.	Injector for cylinder #4 turned OFF.
1341		Stop Vehicle Shut engine OFF/ON. If code clears, resume mission. If code remains, notify maintenance.	Warning - Degraded Operation Severe loss of data from ECM.	No noticeable performance effects possible. Possibility of engine stopping or difficulty in starting engine.
1343		Stop Vehicle Shut engine OFF/ON. If code clears, resume mission. If code remains, notify maintenance.	Warning - Degraded Operation Microprocessor communication error inside ECM.	No noticeable performance effects possible. May encounter severe loss of power.
1346		Finish Mission Notify maintenance.	Information/Maintenance Software error in ECM.	Possibly too short of time for ECM to power down, less than 30 seconds.
1352		Stop Vehicle Press RESET. Finish mission. Notify maintenance.	Warning - Degraded Operation Low voltage detected at sensor. Faulty power supply.	Engine is degraded to no air setting.
1415		Stop Vehicle Check oil level. Press RESET. If error remains, notify maintenance. Finish mission.	Stop Vehicle Immediately Oil pressure signal indicates below critical threshold.	Reduced power and speed. Engine will shut down in 30-45 seconds.
1419		Finish Mission Notify maintenance.	Information/Maintenance Error in intake manifold pressure sensor signal detected by ECM.	Engine is degraded to no air setting.
1431		Finish mission Notify maintenance.	Information/Maintenance Both idle validation off-idle and on-idle signals indicate the same voltage reading.	None.

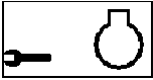
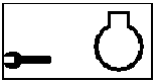
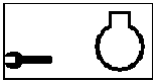
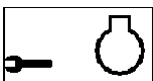
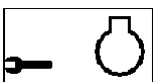
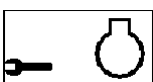
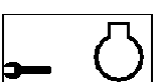
Table 4. Error Codes - Continued.



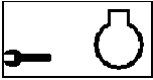
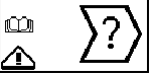
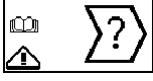
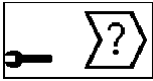
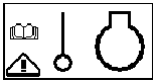
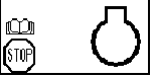

ERROR CODE	DISPLAY LAYOUT	DRIVER ACTION	ERROR CODE EXPLANATION	VEHICLE LIMITATIONS
1432		Stop Vehicle Press RESET. Finish mission. Notify maintenance.	Warning - Degraded Operation Idle validation switch voltages are opposite (complementary) but disagree with a valid throttle position sensor.	Engine will only idle.
1433		Finish Mission Notify maintenance.	Information/Maintenance Intake manifold pressure sensor voltage indicates a high pressure reading.	Engine is degraded to no air setting.
1434		Stop Vehicle Press RESET. Finish mission. Notify maintenance.	Warning - Degraded Operation Battery voltage too low or insufficient amount of time for battery power to ECM for powering down after key off.	No noticeable performance effects possible. Possibility of engine stopping or difficulty in starting engine.
1435		Stop Vehicle Press RESET. Finish mission. Notify maintenance.	Warning - Degraded Operation ECM detects error in oil pressure sensor signal.	None. No engine protection for oil pressure.
1441		Stop Vehicle Press RESET. Finish mission. Notify maintenance.	Warning - Degraded Operation Battery voltage below normal operating level.	No noticeable performance effects possible. Possibility of rough idle.
1442		Stop Vehicle Press RESET. Finish mission. Notify maintenance.	Warning - Degraded Operation Battery voltage above normal operating level.	None.
1443		Stop Vehicle Press RESET. Finish mission. Notify maintenance.	Warning - Degraded Operation Low voltage detected on ECM voltage supply line to throttle.	Engine will only idle.
1474		Stop Vehicle Press RESET. Finish mission. Notify maintenance.	Warning - Degraded Operation Low voltage detected in starter lockout relay circuit when energized or voltage detected when circuit de-energized.	None.

Table 4. Error Codes - Continued.



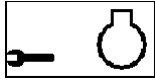

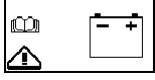
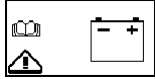

ERROR CODE	DISPLAY LAYOUT	DRIVER ACTION	ERROR CODE EXPLANATION	VEHICLE LIMITATIONS
1551 IVS		Stop Vehicle Press RESET. Finish mission. Notify maintenance.	Warning - Degraded Operation No voltage detected simultaneously in both idle validation off-idle and on-idle circuits.	Engine will only idle.
1581		Stop Vehicle Press RESET. Finish mission. Notify maintenance.	Warning - Degraded Operation High voltage detected in fuel inlet pressure sensor circuit.	None.
1582		Stop Vehicle Press RESET. Finish mission. Notify maintenance.	Warning - Degraded Operation Low voltage detected in fuel inlet pressure sensor circuit.	None.
1583		Stop Vehicle Press RESET. Finish mission. Notify maintenance.	Warning - Degraded Operation Out-of-range low voltage detected in fuel inlet pressure sensor circuit.	None.
1596		Stop Vehicle Press RESET. Finish mission. Notify maintenance.	Warning - Degraded Operation Battery voltage above normal operating range.	None.
1597		Stop Vehicle Press RESET. Finish mission. Notify maintenance.	Warning - Degraded Operation Battery voltage below normal operating range.	None.
1598		Stop Vehicle Abort mission. Notify maintenance.	Stop Vehicle Immediately Very low battery voltage - critical level.	Engine is degraded to no air setting.
1697		Finish Mission Notify maintenance.	Information/Maintenance High voltage detected in ECM internal temperature sensor circuit.	None.

Table 4. Error Codes - Continued.

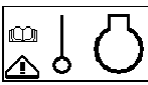
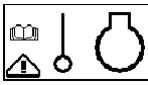
ERROR CODE	DISPLAY LAYOUT	DRIVER ACTION	ERROR CODE EXPLANATION	VEHICLE LIMITATIONS
1698		Finish Mission Notify maintenance.	Information/Maintenance Low voltage detected in ECM internal temperature sensor circuit.	None.
1951		Finish Mission Notify maintenance.	Information/Maintenance Power imbalance between cylinders detected by ECM.	Engine may rough idle or misfire.
1999		Stop Vehicle Press RESET. Check all errors that show. Notify maintenance.	Stop Vehicle Immediately More than 6 errors active on J1939 bus to display.	Engine is degraded to no air setting.

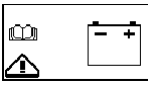
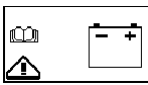
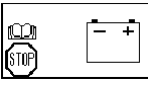
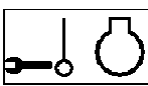
END OF WORK PACKAGE

INDEX

<i>Subject</i>	<i>Work Package/Page</i>
A	
Abbreviations/Acronyms, List of	0001 00-1
Accelerator and Brake Controls	0004 00-9
Additional Authorization List (AAL)	0018 00-1
Air Cleaner, Engine, Servicing	0014 00-1
Air Conditioner, Operate	0005 00-25
Air Transport	0007 00-17
B	
Basic Issue Items (BII) List	0017 00-1
Boom and Tophandler Controls	0004 00-10
Boom, Emergency Lowering	0006 00-4
C	
Components of End Item (COEI) List	0017 00-1
Controls and Indicators, Operator's, Description and Use	0004 00-1
Corrosion Prevention and Control (CPC)	0001 00-1
D	
Decals	
Cab	0008 00-2
Chassis	0008 00-6
Deployment, Self	0007 00-1
Driving	0005 00-8
Driving Tips	0005 00-8
E	
Emergency Lowering of the Boom	0006 00-4
Engine	
Shut Down	0005 00-26
Start	0005 00-3
Equipment Characteristics, Capabilities, and Features	0002 00-1
Equipment Data	0002 00-6
Expendable and Durable items List	0019 00-1
F	
Fire Extinguisher, Portable, Operate	0005 00-27
Fording	0006 00-8
Forklift Kit Installation	0005 00-27
Forklift Plates	0008 00-19

INDEX - Continued

<i>Subject</i>	<i>Work Package/Page</i>
H	
Heater and Defroster, Operate	0005 00-24
Highway Transport	0007 00-11
Horn, Operate	0005 00-26
Hydraulic Controls, Remote	0004 00-12
I	
Initial Adjustments, Daily Checks, and Self-Test	0005 00-2
Instrument Panel	0004 00-1
L	
Lifting Boom and Tophandler, Operate	0005 00-9
Lights, Operate	0005 00-26
List of Abbreviations/Acronyms	0001 00-1
Location and Description of Major Components	0002 00-3
Lubrication Procedures, General	00012 00-3
M	
Marine Transport	0007 00-15
O	
Operate	
Air Conditioner	0005 00-25
Fire Extinguisher, Portable	0005 00-27
Heater and Defroster	0005 00-24
In Extreme Cold	0006 00-5
In Extreme Heat	0006 00-6
In Mud or Soft Surfaces	0006 00-6
In Sandy or Dusty Conditions	0006 00-7
In Woods or on Rocky Terrain	0006 00-8
Lifting Boom and Tophandler	0005 00-9
Lights, Horn, and Front Windshield Wiper/Washer	0005 00-26
On Snow and Ice	0006 00-8
Parking Brake	0005 00-5
Remote Hydraulic Controls	0004 00-12
Transmission	0005 00-4
Ozone Depleting Substances	0001 00-1
P	
Parking and Positioning for Short- and Long-Term Storage	0005 00-34
Parking Brake, Operate	0005 00-5
Plates	0008 00-6

INDEX - Continued

Subject *Work Package/Page*

P - Continued

Plates, Forklift	0008 00-19
Preparation for Storage or Shipment	0001 00-1
Preventive Maintenance Checks and Services (PMCS)	0013 00-1
Preventive Maintenance Checks and Services (PMCS) Introduction	0012 00-1

R

Rail Transport	0007 00-14
References	0016 00-1
Refueling Procedures	0015 00-1
Remote Hydraulic Controls	0004 00-12
Reporting Material Detect	0001 00-1

S

Seat Controls	0004 00-8
Self-Deployment, Transport	0007 00-1
Servicing Engine Air Cleaner	0014 00-1
Shut Down Engine	0005 00-26
Slave Starting	0006 00-2
Start Engine	0005 00-3
Steering	0005 00-6
Steering Wheel and Steering Column Controls	0004 00-7
Stencils	0008 00-6
Storage or Shipment, Preparation for	0001 00-1
Stowage Guide	0008 00-1

T

Theory of Operation	
Brake System	0003 00-2
Cab System	0003 00-3
Cooling System	0003 00-1
Drive Train	0003 00-1
Electrical System	0003 00-1
Electronic System	0003 00-3
Exhaust System	0003 00-1
Forklift Kit	0003 00-3
Fuel System	0003 00-1
Hydraulic System	0003 00-2
Lifting Boom and Tophandler	0003 00-3

INDEX - Continued

Subject *Work Package/Page*

T - Continued

Theory of Operation - Continued	
Steering System	0003 00-2
Towing	0006 00-3
Transmission, Operate	0005 00-4
Transport	
Air	0007 00-17
Highway	0007 00-11
Marine	0007 00-15
Placing Boom Support in Transport Position	0007 00-7
Placing Cab in Transport Position	0007 00-2
Rail	0007 00-14
Self-Deployment	0007 00-1
Troubleshooting	
Instructions	0009 00-1
Procedures	0011 00-1
Symptom Index	0010 00-1

W

Warranty Information	0001 00-1
Windshield Wiper/Washer, Front, Operate	0005 00-26

By Order of the Secretary of the Army:

PETER J. SCHOOMAKER
General, United States Army
Chief of Staff

Official:

JOYCE E. MORROW
Administrative Assistant to the
Secretary of the Army
0631804

BY DIRECTION OF THE COMMANDANT OF THE MARINE CORPS
G.W. TAYLOR
Product Group Director, PG-15
Ground Transportation Engineer Systems
Marine Corps Systems Command

ARMY DISTRIBUTION: To be distributed in accordance with the initial distribution requirements for IDN: 256667
TM 10-3930-675-10-2.

MARINE CORPS DISTRIBUTION: PCN 184 110781 00

RECOMMENDED CHANGES TO PUBLICATIONS AND BLANK FORMS For use of this form, see AR 25-30; the proponent agency is OAASA						Use Part II (<i>reverse</i>) for Repair Parts and Special Tool Lists (RPSTL) and Supply Catalogs/Supply Manuals (SC/SM).	DATE 1 July 2009
TO: (<i>Forward to proponent of publication or form</i>) (<i>Include ZIP Code</i>) AMSTA-LC-LMPP/TECH PUBS, TACOM-RI 1 Rock Island Arsenal Rock Island, IL 61299-7630						FROM: (<i>Activity and location</i>) (<i>Include ZIP Code</i>)	
PART I - ALL PUBLICATIONS (EXCEPT RPSTL AND SC/SM) AND BLANK FORMS							
PUBLICATION/FORM NUMBER TM 10-3930-675-10-2						DATE 1 December 2006	TITLE Operator's Manual for Rough Terrain Container Handler (RTCH-RT 240V2)
ITEM	PAGE	PARA-	LINE	FIGURE NO.	TABLE	RECOMMENDED CHANGES AND REASON	
	0017 00-2					Part number supplied for item 2 is incorrect.	
<h1>SAMPLE</h1>							
TYPED NAME, GRADE OR TITLE					TELEPHONE EXCHANGE/AUTOVON, PLUS EXTENSION		SIGNATURE

TO: <i>(Forward direct to addressee listed in publication)</i> AMSTA-LC-LMPP/TECH PUBS, TACOM-RI 1 Rock Island Arsenal Rock Island, IL 61299-7630	FROM: <i>(Activity and location) (Include ZIP Code)</i>	DATE
---	--	-------------

PART II - REPAIR PARTS AND SPECIAL TOOL LISTS AND SUPPLY CATALOGS/SUPPLY MANUALS

PUBLICATION NUMBER TM 10-3930-675-10-2	DATE 01 Dec 06	TITLE Operator's Manual for Rough Terrain Container Handler (RTCH-RT240V2)
--	--------------------------	---

PAGE NO.	COLM NO.	LINE NO.	NATIONAL STOCK NUMBER	REFERENCE NO.	FIGURE NO.	ITEM NO.	TOTAL NO. OF MAJOR ITEMS SUPPORTED	RECOMMENDED ACTION
<h1>SAMPLE</h1>								

PART III - REMARKS *(For larger items, parts, or supplies for repair of publications and for additional sheets may be used. Space provided.)*

TYPED NAME, GRADE OR TITLE	TELEPHONE EXCHANGE/AUTOVON, PLUS EXTENSION	SIGNATURE
-----------------------------------	---	------------------

RECOMMENDED CHANGES TO PUBLICATIONS AND BLANK FORMS For use of this form, see AR 25-30; the proponent agency is OAASA						Use Part II (<i>reverse</i>) for Repair Parts and Special Tool Lists (RPSTL) and Supply Catalogs/Supply Manuals (SC/SM).	DATE
TO: (<i>Forward to proponent of publication or form</i>) (<i>Include ZIP Code</i>) AMSTA-LC-LMPP/TECH PUBS, TACOM-RI 1 Rock Island Arsenal Rock Island, IL 61299-7630						FROM: (<i>Activity and location</i>) (<i>Include ZIP Code</i>)	
PART I - ALL PUBLICATIONS (EXCEPT RPSTL AND SC/SM) AND BLANK FORMS							
PUBLICATION/FORM NUMBER TM 10-3930-675-10-2				DATE 01 December 2006	TITLE Operator's Manual for Rough Terrain Container Handler (RTCH-RT 240V2)		
ITEM	PAGE	PARA-	LINE	FIGURE NO.	TABLE	RECOMMENDED CHANGES AND REASON	
TYPED NAME, GRADE OR TITLE					TELEPHONE EXCHANGE/AUTOVON, PLUS EXTENSION		SIGNATURE

TO: <i>(Forward direct to addressee listed in publication)</i> AMSTA-LC-LMPP/TECH PUBS, TACOM-RI 1 Rock Island Arsenal Rock Island, IL 61299-7630	FROM: <i>(Activity and location) (Include ZIP Code)</i>	DATE
---	--	-------------

PART II - REPAIR PARTS AND SPECIAL TOOL LISTS AND SUPPLY CATALOGS/SUPPLY MANUALS

PUBLICATION NUMBER TM 10-3930-675-10-2	DATE 01 Dec 06	TITLE Operator's Manual for Rough Terrain Container Handler (RTCH-RT240V2)
--	--------------------------	---

PAGE NO.	COLM NO.	LINE NO.	NATIONAL STOCK NUMBER	REFERENCE NO.	FIGURE NO.	ITEM NO.	TOTAL NO. OF MAJOR ITEMS SUPPORTED	RECOMMENDED ACTION

PART III - REMARKS *(Any general remarks or recommendations, or suggestions for improvement of publications and blank forms. Additional blank sheets may be used if more space is needed.)*

TYPED NAME, GRADE OR TITLE	TELEPHONE EXCHANGE/AUTOVON, PLUS EXTENSION	SIGNATURE
----------------------------	--	-----------

RECOMMENDED CHANGES TO PUBLICATIONS AND BLANK FORMS For use of this form, see AR 25-30; the proponent agency is OAASA						Use Part II (<i>reverse</i>) for Repair Parts and Special Tool Lists (RPSTL) and Supply Catalogs/Supply Manuals (SC/SM).	DATE
TO: (<i>Forward to proponent of publication or form</i>) (<i>Include ZIP Code</i>) AMSTA-LC-LMPP/TECH PUBS, TACOM-RI 1 Rock Island Arsenal Rock Island, IL 61299-7630						FROM: (<i>Activity and location</i>) (<i>Include ZIP Code</i>)	
PART I - ALL PUBLICATIONS (EXCEPT RPSTL AND SC/SM) AND BLANK FORMS							
PUBLICATION/FORM NUMBER TM 10-3930-675-10-2				DATE 01 December 2006	TITLE Operator's Manual for Rough Terrain Container Handler (RTCH-RT 240V2)		
ITEM	PAGE	PARA-	LINE	FIGURE NO.	TABLE	RECOMMENDED CHANGES AND REASON	
TYPED NAME, GRADE OR TITLE					TELEPHONE EXCHANGE/AUTOVON, PLUS EXTENSION		SIGNATURE

TO: <i>(Forward direct to addressee listed in publication)</i> AMSTA-LC-LMPP/TECH PUBS, TACOM-RI 1 Rock Island Arsenal Rock Island, IL 61299-7630	FROM: <i>(Activity and location) (Include ZIP Code)</i>	DATE
---	--	-------------

PART II - REPAIR PARTS AND SPECIAL TOOL LISTS AND SUPPLY CATALOGS/SUPPLY MANUALS

PUBLICATION NUMBER TM 10-3930-675-10-2	DATE 01 Dec 06	TITLE Operator's Manual for Rough Terrain Container Handler (RTCH-RT240V2)
--	--------------------------	---

PAGE NO.	COLM NO.	LINE NO.	NATIONAL STOCK NUMBER	REFERENCE NO.	FIGURE NO.	ITEM NO.	TOTAL NO. OF MAJOR ITEMS SUPPORTED	RECOMMENDED ACTION

PART III - REMARKS *(Any general remarks or recommendations, or suggestions for improvement of publications and blank forms. Additional blank sheets may be used if more space is needed.)*

TYPED NAME, GRADE OR TITLE	TELEPHONE EXCHANGE/AUTOVON, PLUS EXTENSION	SIGNATURE
----------------------------	--	-----------

RECOMMENDED CHANGES TO PUBLICATIONS AND BLANK FORMS For use of this form, see AR 25-30; the proponent agency is OAASA						Use Part II (<i>reverse</i>) for Repair Parts and Special Tool Lists (RPSTL) and Supply Catalogs/Supply Manuals (SC/SM).	DATE
TO: (<i>Forward to proponent of publication or form</i>) (<i>Include ZIP Code</i>) AMSTA-LC-LMPP/TECH PUBS, TACOM-RI 1 Rock Island Arsenal Rock Island, IL 61299-7630						FROM: (<i>Activity and location</i>) (<i>Include ZIP Code</i>)	
PART I - ALL PUBLICATIONS (EXCEPT RPSTL AND SC/SM) AND BLANK FORMS							
PUBLICATION/FORM NUMBER TM 10-3930-675-10-2				DATE 01 December 2006	TITLE Operator's Manual for Rough Terrain Container Handler (RTCH-RT 240V2)		
ITEM	PAGE	PARA-	LINE	FIGURE NO.	TABLE	RECOMMENDED CHANGES AND REASON	
TYPED NAME, GRADE OR TITLE					TELEPHONE EXCHANGE/AUTOVON, PLUS EXTENSION		SIGNATURE

TO: <i>(Forward direct to addressee listed in publication)</i> AMSTA-LC-LMPP/TECH PUBS, TACOM-RI 1 Rock Island Arsenal Rock Island, IL 61299-7630	FROM: <i>(Activity and location) (Include ZIP Code)</i>	DATE
---	--	-------------

PART II - REPAIR PARTS AND SPECIAL TOOL LISTS AND SUPPLY CATALOGS/SUPPLY MANUALS

PUBLICATION NUMBER TM 10-3930-675-10-2	DATE 01 Dec 06	TITLE Operator's Manual for Rough Terrain Container Handler (RTCH-RT240V2)
--	--------------------------	---

PAGE NO.	COLM NO.	LINE NO.	NATIONAL STOCK NUMBER	REFERENCE NO.	FIGURE NO.	ITEM NO.	TOTAL NO. OF MAJOR ITEMS SUPPORTED	RECOMMENDED ACTION

PART III - REMARKS *(Any general remarks or recommendations, or suggestions for improvement of publications and blank forms. Additional blank sheets may be used if more space is needed.)*

TYPED NAME, GRADE OR TITLE	TELEPHONE EXCHANGE/AUTOVON, PLUS EXTENSION	SIGNATURE
----------------------------	--	-----------

THE METRIC SYSTEM AND EQUIVALENTS

<p>Linear Measure</p> <p>1 Centimeter = 10 Millimeters = 0.01 Meters = 0.3937 Inches 1 Meter = 100 Centimeters = 1000 Millimeters = 39.37 Inches 1 Kilometer = 1000 Meters = 0.621 Miles</p> <p>Weights</p> <p>1 Gram = 0.001 Kilograms = 1000 Milligrams = 0.035 Ounces 1 Kilogram = 1000 Grams = 2.2 Pounds 1 Metric Ton = 1000 Kilograms = 1 Megagram = 1.1 Short Tons</p> <p>Liquid Measure</p> <p>1 Milliliter = 0.001 Liters = 0.0338 Fluid Ounces 1 Liter = 1000 Milliliters = 33.82 Fluid Ounces</p>	<p>Square Measure</p> <p>1 Sq Centimeter = 100 Sq Millimeters = 0.155 Sq Inches 1 Sq Meter = 10,000 Sq Centimeters = 10.76 Sq Feet 1 Sq Kilometer = 1,000,000 Sq Meters = 0.386 Sq Miles</p> <p>Cubic Measure</p> <p>1 Cu Centimeter = 1,000 Cu Millimeters = 0.06 Cu Inches 1 Cu Meter = 1,000,000 Cu Centimeters = 35.31 Cu Feet</p> <p>Temperature</p> <p>$5/9 (^{\circ}\text{F} - 32) = ^{\circ}\text{C}$ 212° Fahrenheit is equivalent to 100° Celsius 90° Fahrenheit is equivalent to 32.2° Celsius 32° Fahrenheit is equivalent to 0° Celsius $9/5 \text{ C}^{\circ} + 32 = \text{F}^{\circ}$</p>
--	--

APPROXIMATE CONVERSION FACTORS

To Change	To	Multiply By
Inches	Centimeters	2.540
Feet	Meters	0.305
Yards	Meters	0.914
Miles	Kilometers	1.609
Sq Inches	Sq Centimeters	6.451
Sq Feet	Sq Meters	0.093
Sq Yards	Sq Meters	0.836
Sq Miles	Sq Kilometers	2.590
Acres	Sq Hectometers	0.405
Cubic Feet	Cubic Meters	0.028
Cubic Yards	Cubic Meters	0.765
Fluid Ounces	Milliliters	29.573
Pints	Liters	0.473
Quarts	Liters	0.946
Gallons	Liters	3.785
Ounces	Grams	28.349
Pounds	Kilograms	0.454
Short Tons	Metric Tons	0.907
Pound-Feet	Newton-Meters	1.356
Pounds per Sq Inch	Kilopascals	6.895
Miles per Gallon	Kilometers per Liter	0.425
Miles per Hour	Kilometers per Hour	1.609

To Change	To	Multiply By
Centimeters	Inches	0.394
Meters	Feet	3.280
Meters	Yards	1.094
Kilometers	Miles	0.621
Sq Centimeters	Sq Inches	0.155
Sq Meters	Sq Feet	10.764
Sq Meters	Sq Yards	1.196
Sq Kilometers	Sq Miles	0.386
Sq Hectometers	Acres	2.471
Cubic Meters	Cubic Feet	35.315
Cubic Meters	Cubic Yards	1.308
Milliliters	Fluid Ounces	0.034
Liters	Pints	2.113
Liters	Quarts	1.057
Liters	Gallons	0.264
Grams	Ounces	0.035
Kilograms	Pounds	2.205
Metric Tons	Short Tons	1.102
Newton-Meters	Pound-Feet	0.738
Kilopascals	Pounds per Sq Inch	0.145
Kilometers per Liter	Miles per Gallon	2.354
Kilometers per Hour	Miles per Hour	0.621

